





Read this instruction carefully. See hardware and furniture part list for guidance. Be sure all parts are complete, before you assemble. Place all wooden furniture parts on a clean and flat soft surface to prevent from being scratched. Follow the figure to start assembling.

PART LIST			
ITEM	DESCRIPTION	BOX	QTY
A	CHAIR	1	1 PC
B	LEG	1	4 PCS

HARDWARE LIST (BOX :1)			
ITEM	DESCRIPTION		QTY
1	JCBB BOLT M8 x 50mm		8 PCS
2	M8 FLAT WASHER		8 PCS
3	M8 SPRING WASHER		8 PCS
4	M5 ALLEN KEY (BALL SHAPE)		1 PC

CAUTION : 1. Do not FULLY - TIGHTEN the nuts or nuts bolts until they are ready for assembly.
 2. Do not OVER - TIGHTEN the nuts or bolts to avoid causing damages to the thread.
 3. Keep all hardware parts out of reach of children.

NOTE : THE LIST AND QUANTITY SHOWN ARE FOR 1 UNIT ASSEMBLY.

Tools needed : Screwdriver (not provided).

STEP 1

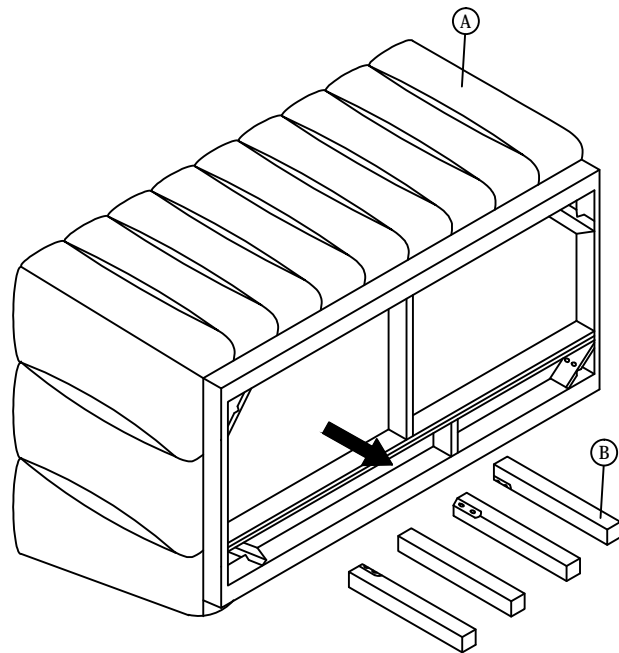

STEP 2

BOTTOM VIEW

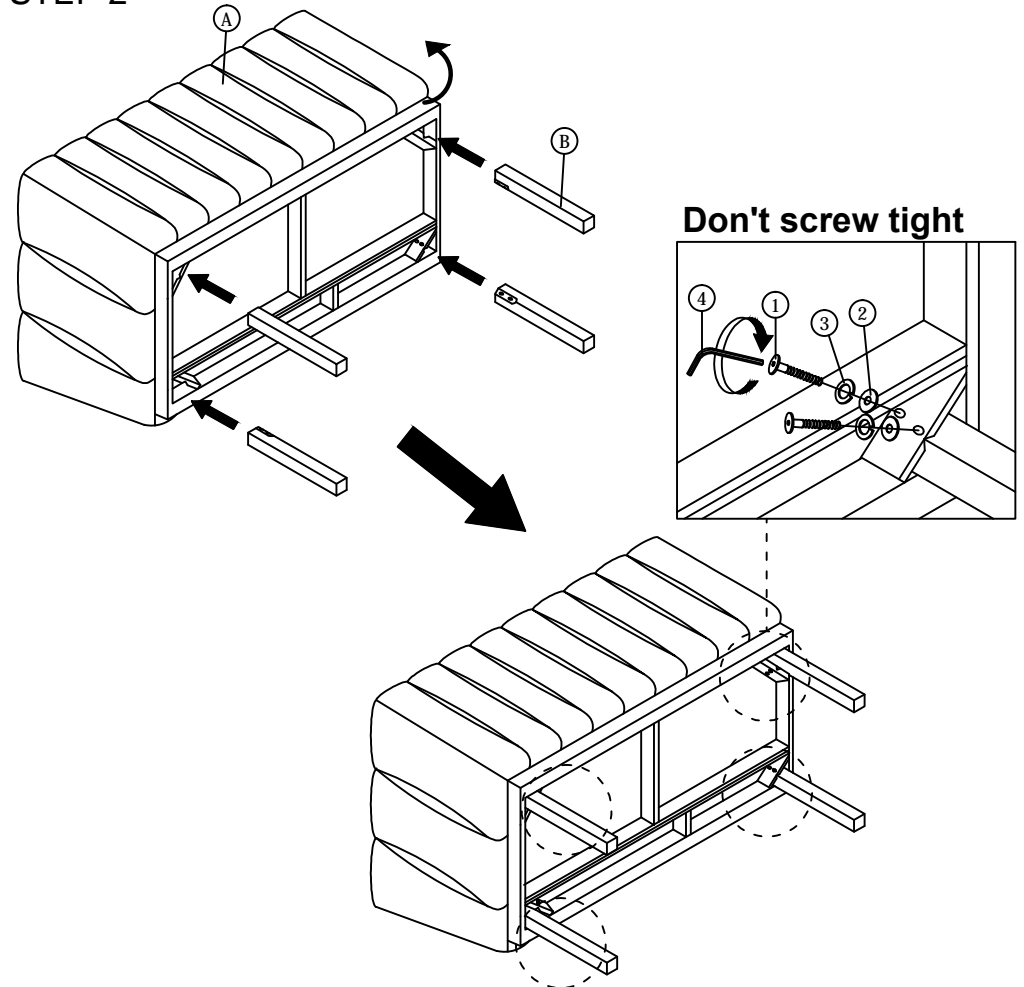

STEP 3

Place the chair on the flat surface and adjust the alignment and balance of the legs then , Please screw tight the steps 1 bolts.

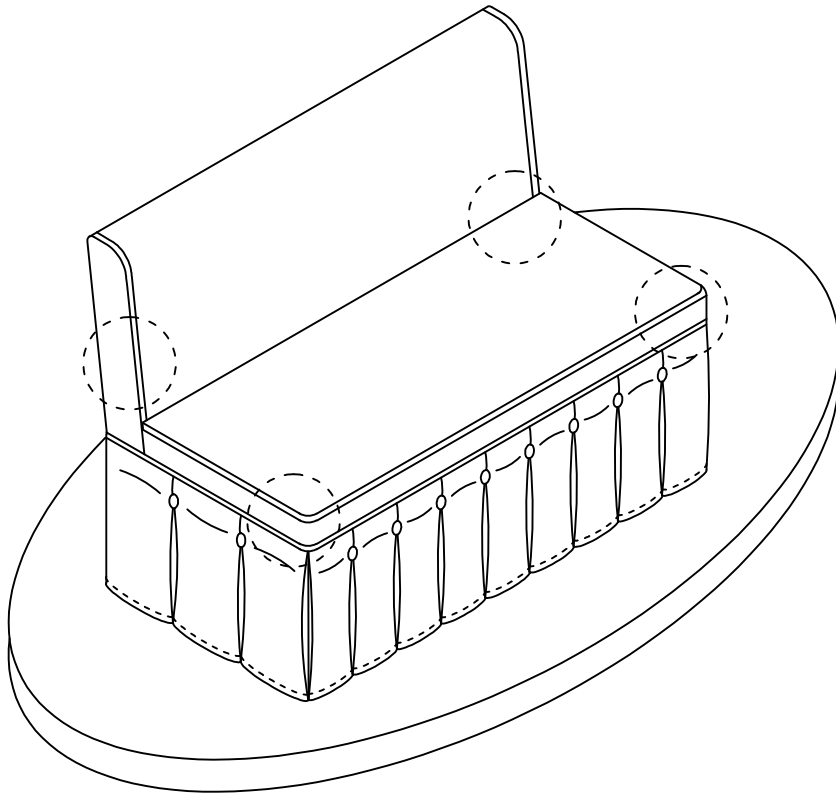



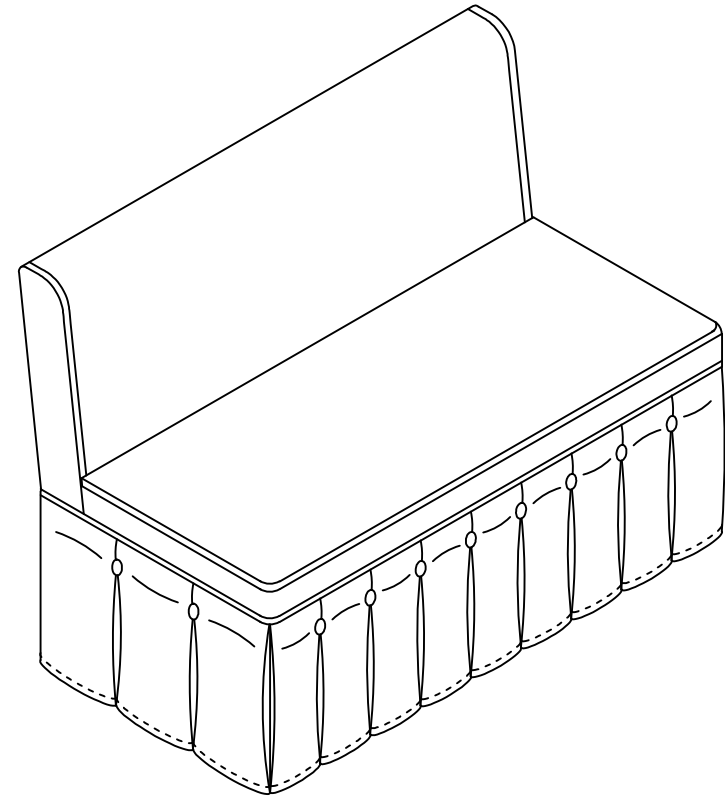

STEP 4



Read this instruction carefully. See hardware and furniture part list for guidance. Be sure all parts are complete, before you assemble. Place all wooden furniture parts on a clean and flat soft surface to prevent from being scratched. Follow the figure to start assembling.

PART LIST			
ITEM	DESCRIPTION	BOX	QTY
A	CHAIR	1	1 PC
B	LEG	1	4 PCS

HARDWARE LIST (BOX :1)			
ITEM	DESCRIPTION		QTY
1	JCBB BOLT M8 x 50mm		8 PCS
2	M8 FLAT WASHER		8 PCS
3	M8 SPRING WASHER		8 PCS
4	M5 ALLEN KEY (BALL SHAPE)		1 PC

CAUTION : 1. Do not FULLY - TIGHTEN the nuts or nuts bolts until they are ready for assembly.
 2. Do not OVER - TIGHTEN the nuts or bolts to avoid causing damages to the thread.
 3. Keep all hardware parts out of reach of children.

NOTE : THE LIST AND QUANTITY SHOWN ARE FOR 1 UNIT ASSEMBLY.

Tools needed : Screwdriver (not provided).

STEP 1

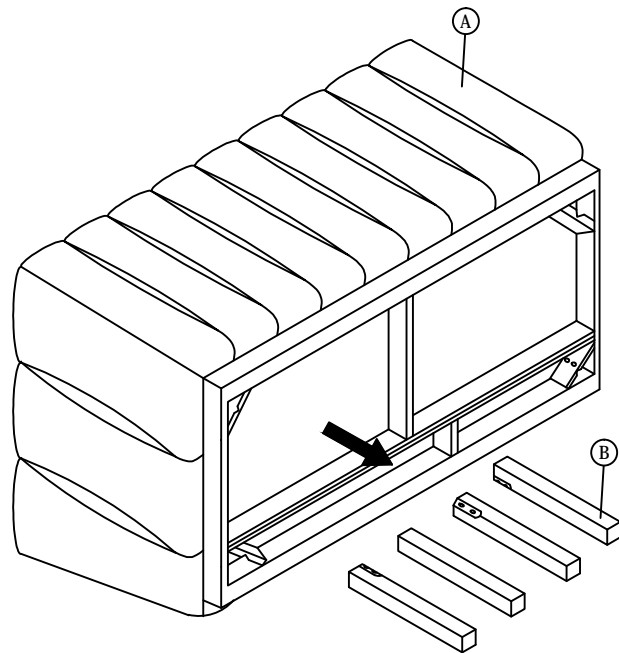

STEP 2

BOTTOM VIEW

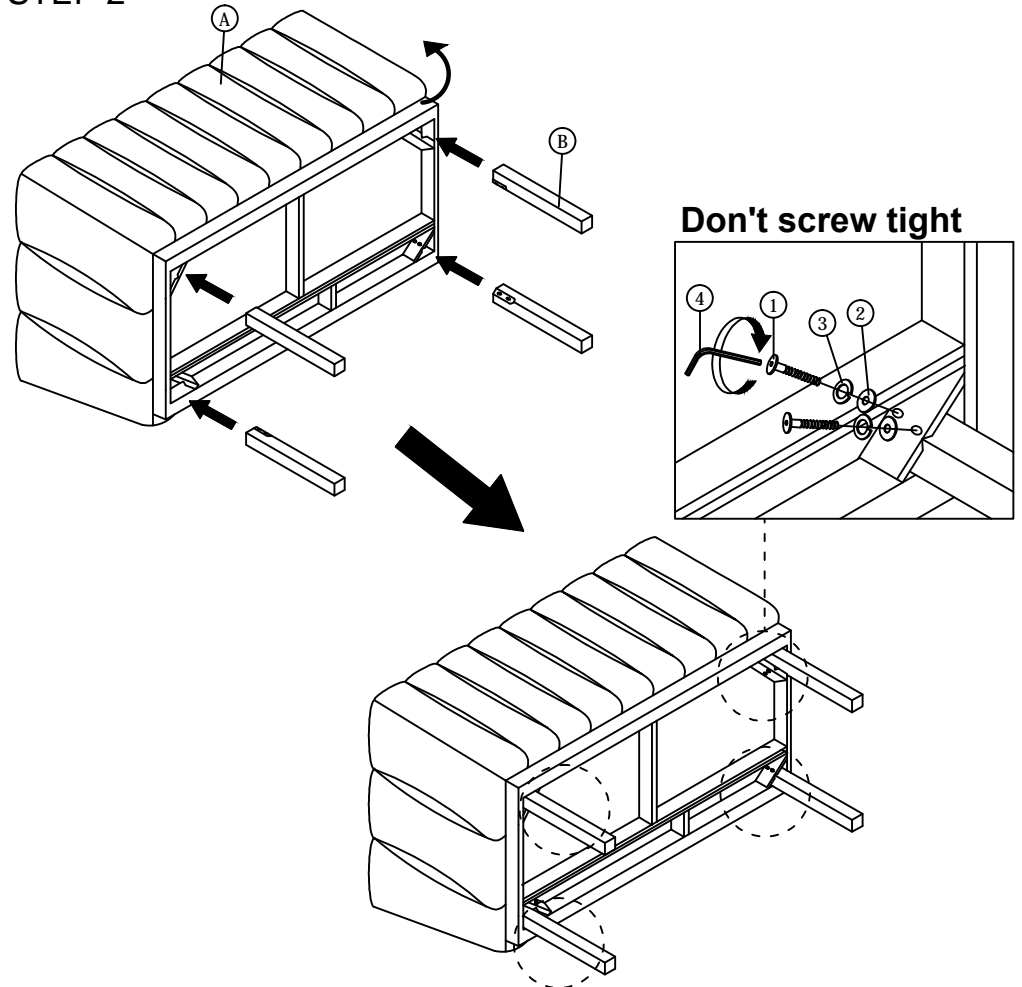

ASSEMBLY INSTRUCTIONS

STEP 3

Place the chair on the flat surface and adjust the alignment and balance of the legs then , Please screw tight the steps 1 bolts.

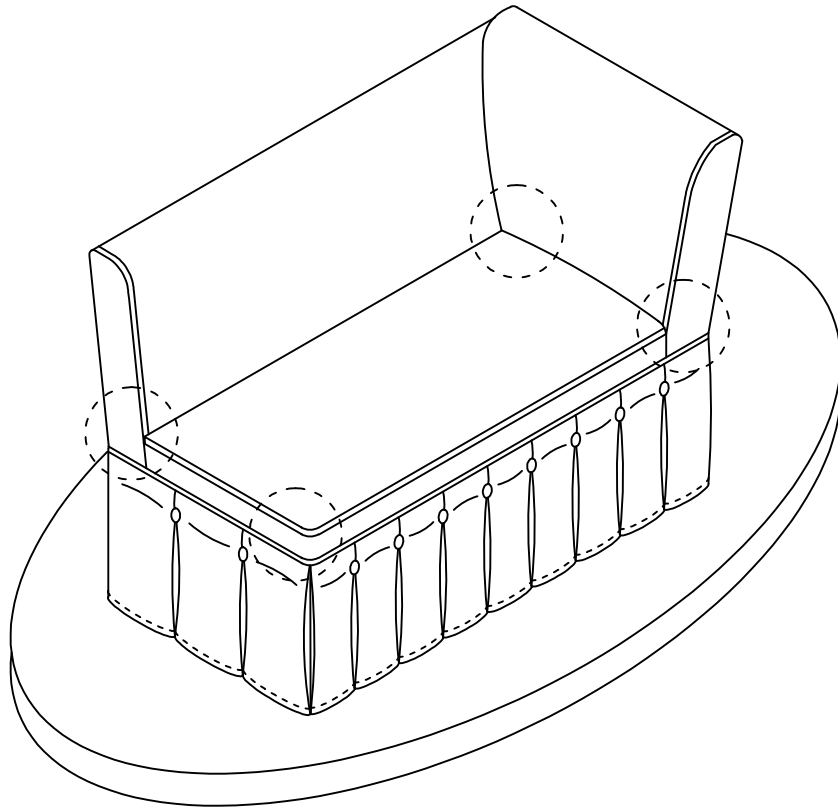

STEP 4

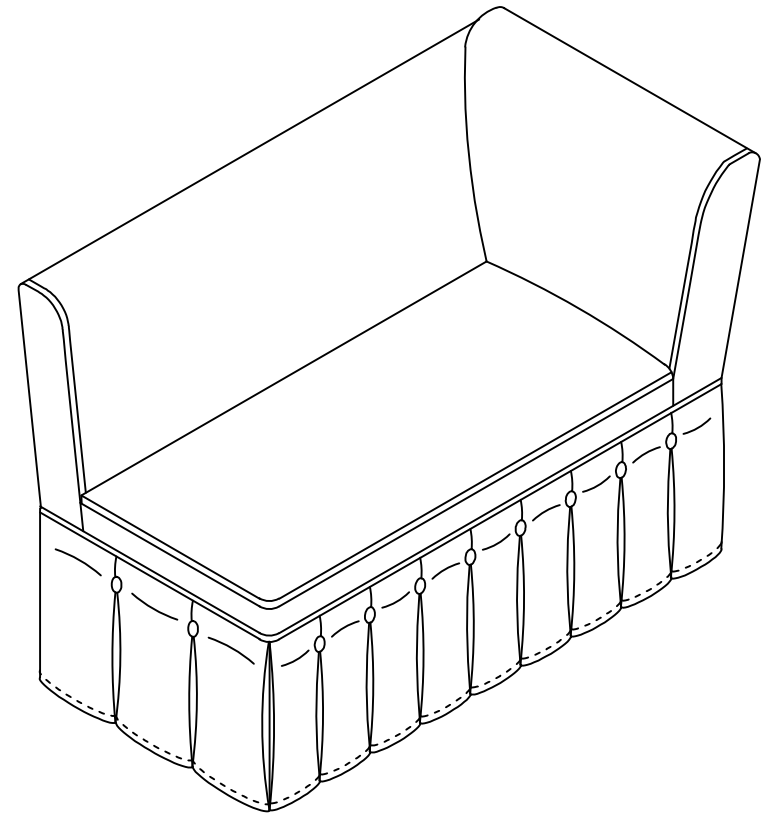

Read this instruction carefully. See hardware and furniture part list for guidance. Be sure all parts are complete, before you assemble. Place all wooden furniture parts on a clean and flat soft surface to prevent from being scratched. Follow the figure to start assembling.

CAUTIONS : 1. Do not FULLY - TIGHTEN the nut or nut bolt until all nut or bolt is ready assembled.
 2. Do not OVER - TIGHTEN the nut or bolt to avoid causing damages to the thread.
 3. Keep all hardware parts out of reach of children.

NOTE : THE LIST AND QUANTITY SHOWN ARE FOR 1 UNIT ASSEMBLY.

Tool needed : Screwdriver (not provider).

PART LIST		
ITEM	DESCRIPTION	QTY
A	TABLE TOP	1 PC
B	LEGS	4 PCS

PART LIST		
ITEM	DESCRIPTION	QTY
1	JCBC BOLT M6 x 35mm	8 PCS
2	M6 SPRING WASHER	8 PCS
3	WOOD SCREW M4 x 32mm	8 PCS
4	M4 ALLEN KEY	1 PC

STEP 1

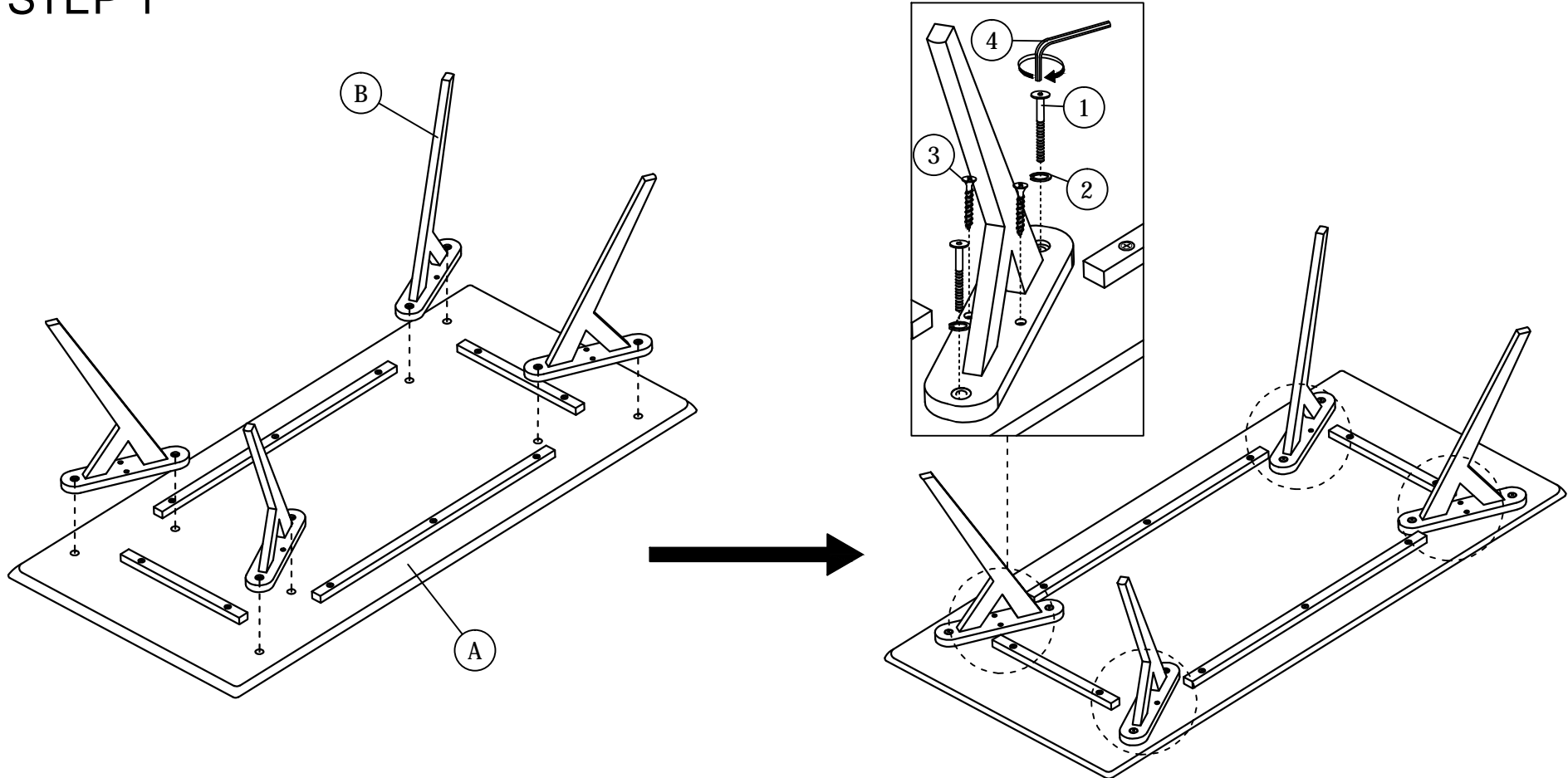

STEP 2

