

SW 8596 - F/Q/K

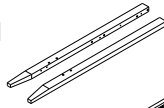

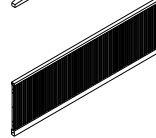

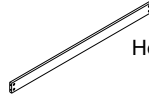

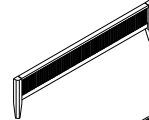
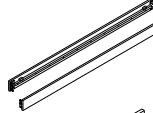
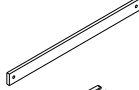
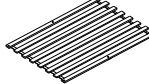
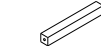

WARNING!!

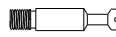
- Remove hardware from box and sort by size.
- Please check to see that hardware and parts are present prior start of assembly.
- Please follow attached instruction in the same sequence numbered to ensure fast and easy assembly.
- Do not use this bed if any part is broken, torn or missing.
- The assembly of this product requires two people.
- Do not use any power tools as this may damage the frame and will invalidate any claim.

PART LIST

P1		Headboard Post = L-1pc = R-1pc
P2		Headboard Panel = 1pc
P3		Headboard Bottom Rail = 1pc
P4		Footboard = 1pc
P5		Side Rail = 2pcs
P6		Center Rail = 2pcs
P7		Bed Slats = 14pcs
P8		Support Leg = 4pcs

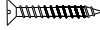
HARDWARE LIST

A		MINIFIX SCREW 24MM = 10pcs
B		MINIFIX HOUSING Ø15 X 10MM = 10pcs
C		M6 X 50MM JCBC = 4pcs
D		M8 X 16MM JCBB = 8pcs
E		WOOD DOWEL M8 X 30MM = 8pcs
F		ALLEN KEY M4 = 1pc
G		ALLEN KEY M5 = 1pc
H		M4 X 25MM SCREW = 8pcs
I		ADJUSTER = 4pcs

1.

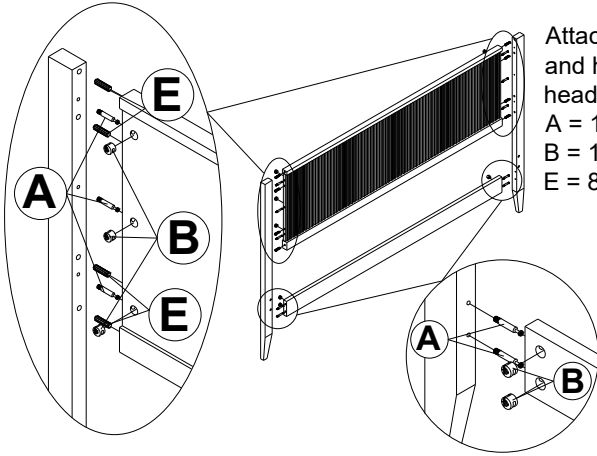

Attach the headboard bottom rail (P3) and headboard panel (P2) to the headboard post (P1). You will need to
 A = 10pcs
 B = 10pc
 E = 8pcs

2.

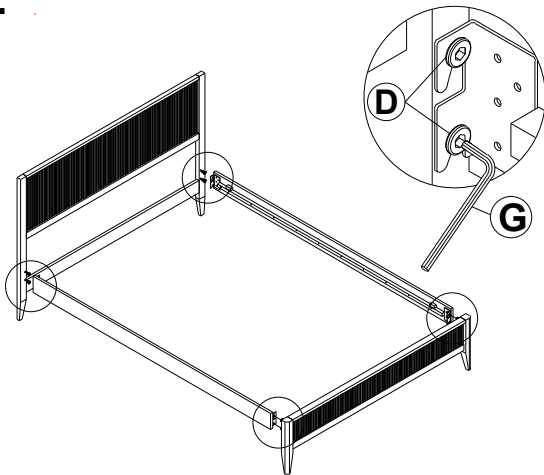

Attach the side rail (P5) to the footboard (P4) and headboard post (P1) using hardware:
 D = 8pcs
 G = 1pc

3.

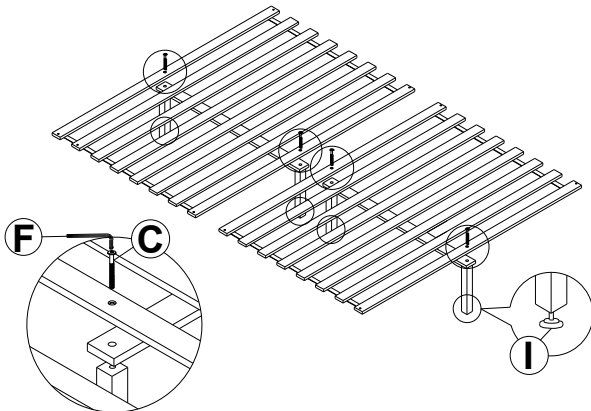

Fix the adjuster (I) to the support leg (P8) using hardware:
 I = 4pcs

Attach the support leg (P8) to the center rail (P6) and bed slats (P7) using hardware:
 C = 4pcs
 F = 1pc

4.

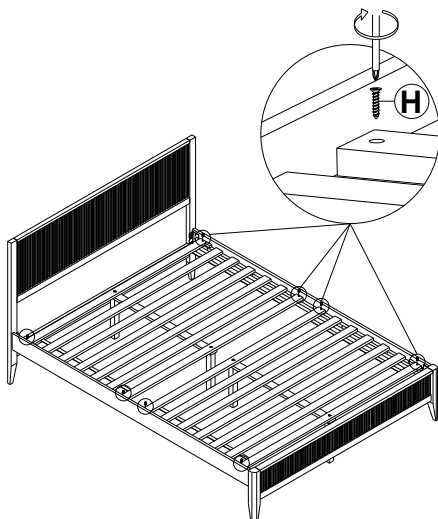

Lay the bed slats (P7) between the side rail (P5) using hardware:
 H = 8pcs

****Apply pressure with your knee to the side rail whilst attaching the slats to ensure that the slats are flush against the inside of side rail****



ASSEMBLY INSTRUCTION

SW 8000-66NS

REAR

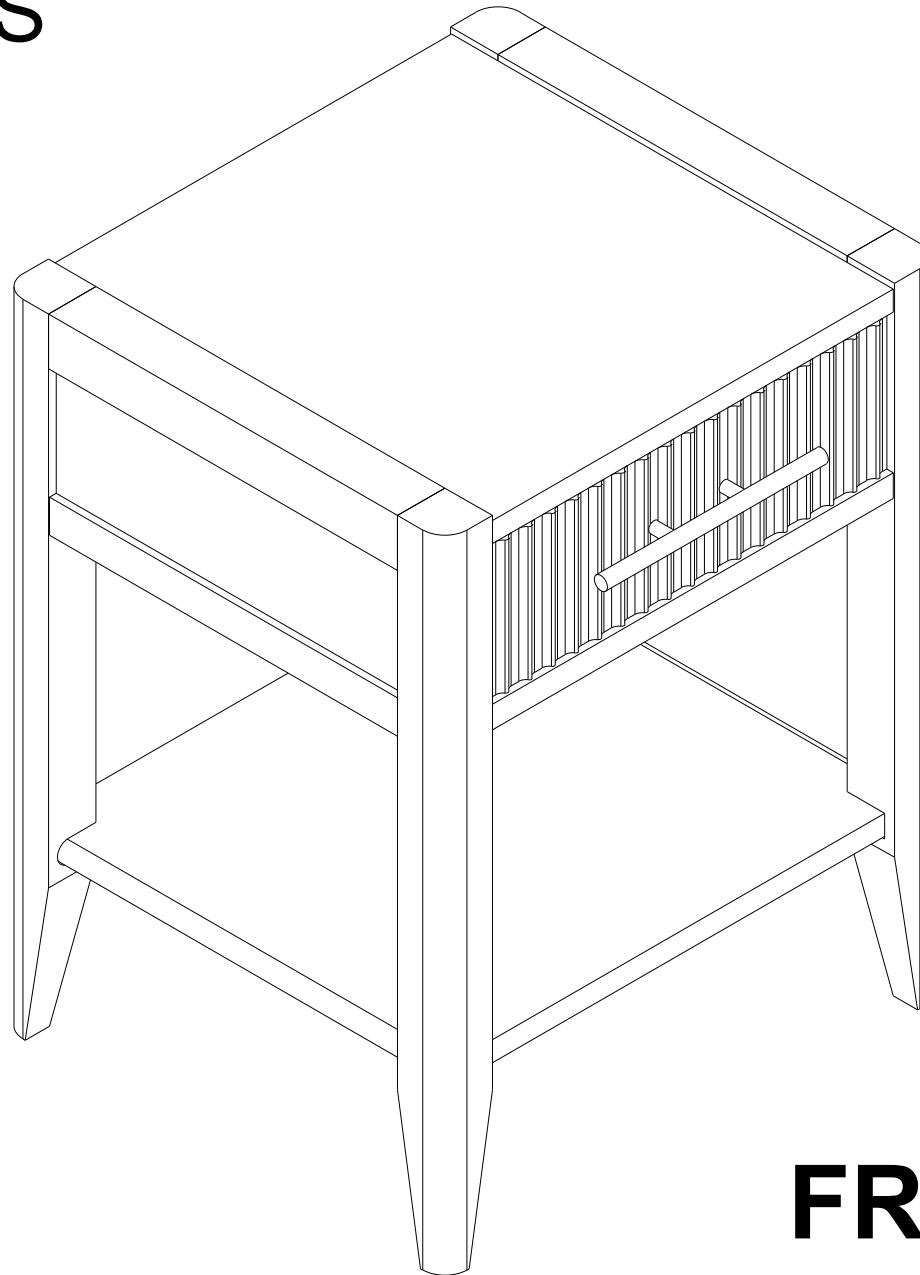





FRONT

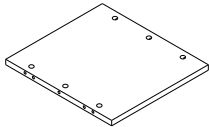
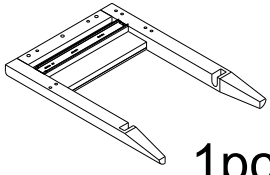
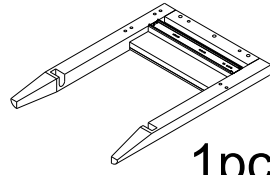
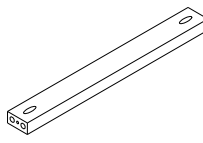
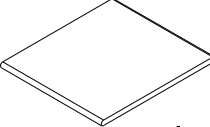
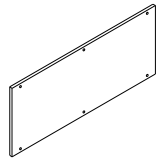
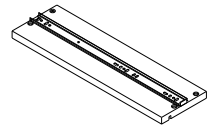
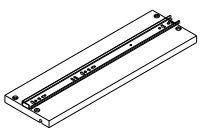
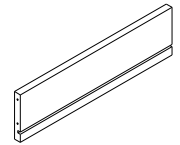
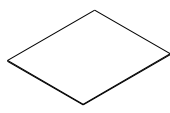
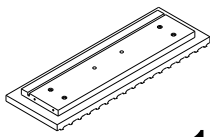

PART LIST

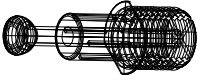
<p>1 Top Panel</p>  <p>1pc</p>	<p>2 Handle(left)</p>  <p>1pc</p>	<p>3 Handle(right)</p>  <p>1pc</p>	<p>4 Support Rail</p>  <p>3pcs</p>	<p>5 Bottom Panel</p>  <p>1pc</p>	<p>6 Back Panel</p>  <p>1pc</p>
<p>7 Drawer Side Panel(left)</p>  <p>1pc</p>	<p>8 Drawer Side Panel(right)</p>  <p>1pc</p>	<p>9 Drawer Rear Panel</p>  <p>1pc</p>	<p>10 Drawer Base Panel</p>  <p>1pc</p>	<p>11 Drawer Front Panel</p>  <p>1pc</p>	

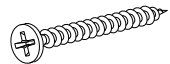
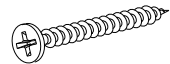
HARDWARE LIST

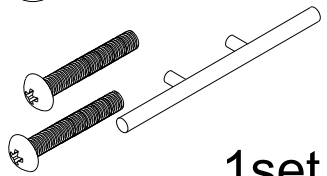
<p>A MINI FIX SPREADING BOLT 24MM</p>  <p>6pcs</p>	<p>B MINIFIX HOUSING Ø15*12MM</p>  <p>6pcs</p>	<p>C WOOD DOWEL M8*30MM</p>  <p>16pcs</p>	<p>D CSK SCREW M4*30MM</p>  <p>6pcs</p>	<p>E CSK SCREW M4*25MM</p>  <p>8pcs</p>	<p>F PAN HEAD M3.5*16MM</p>  <p>6pcs</p>
<p>G HANDLE</p>  <p>1set</p>					

STEP 1

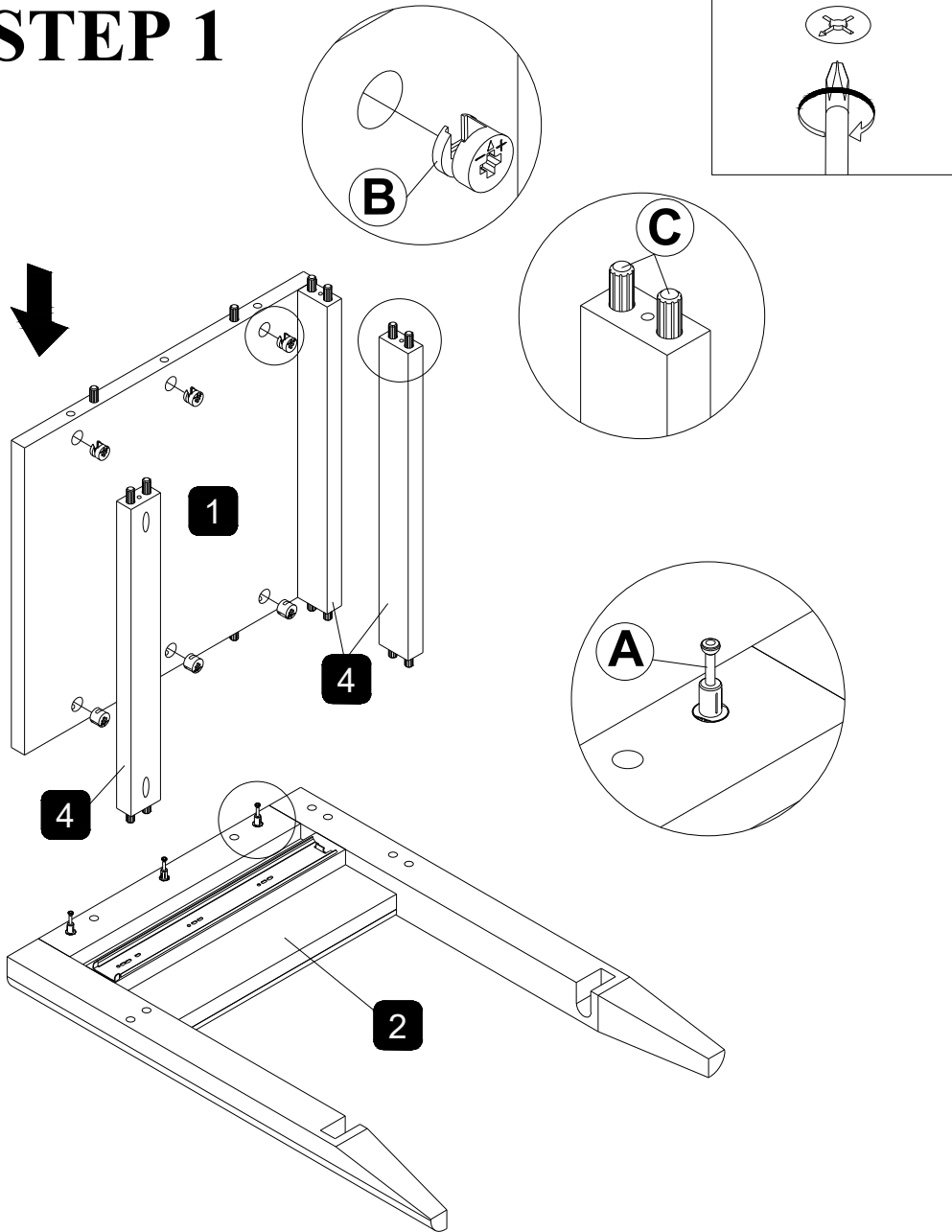

STEP 2

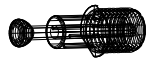
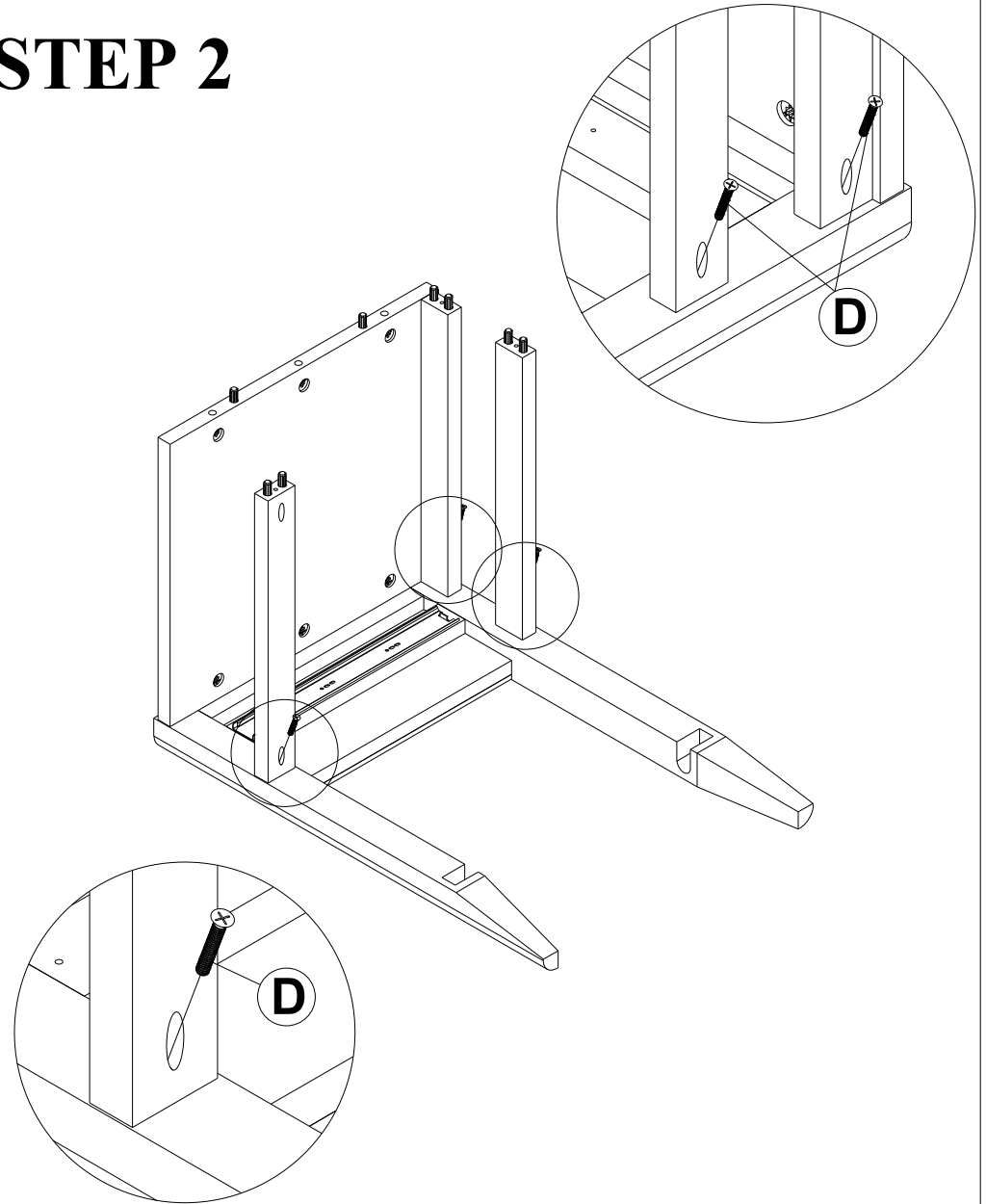

A X 3pcs



B X 6pcs

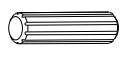

C X 16pcs

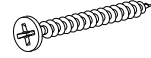

D X 3pcs



STEP 3

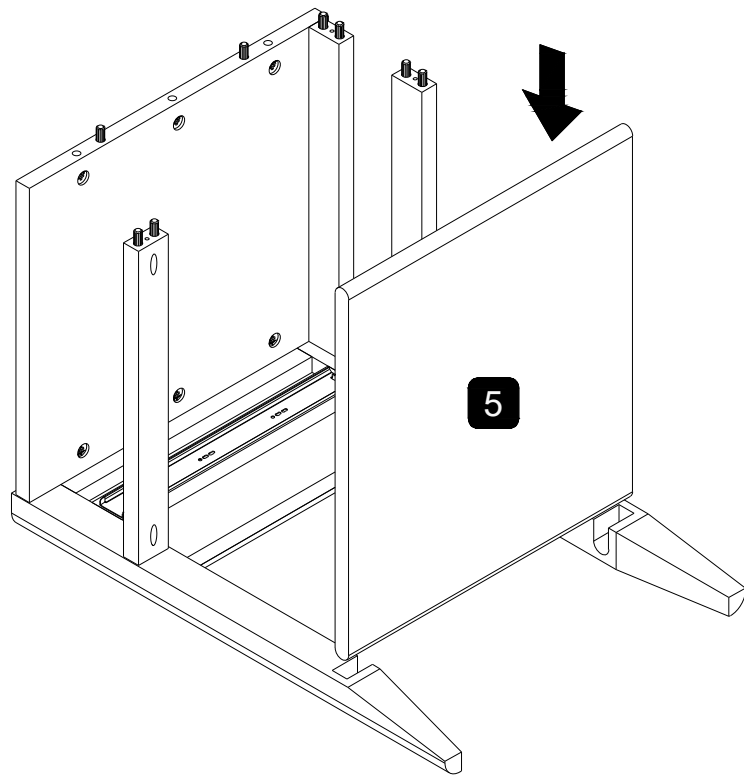

STEP 4

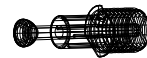
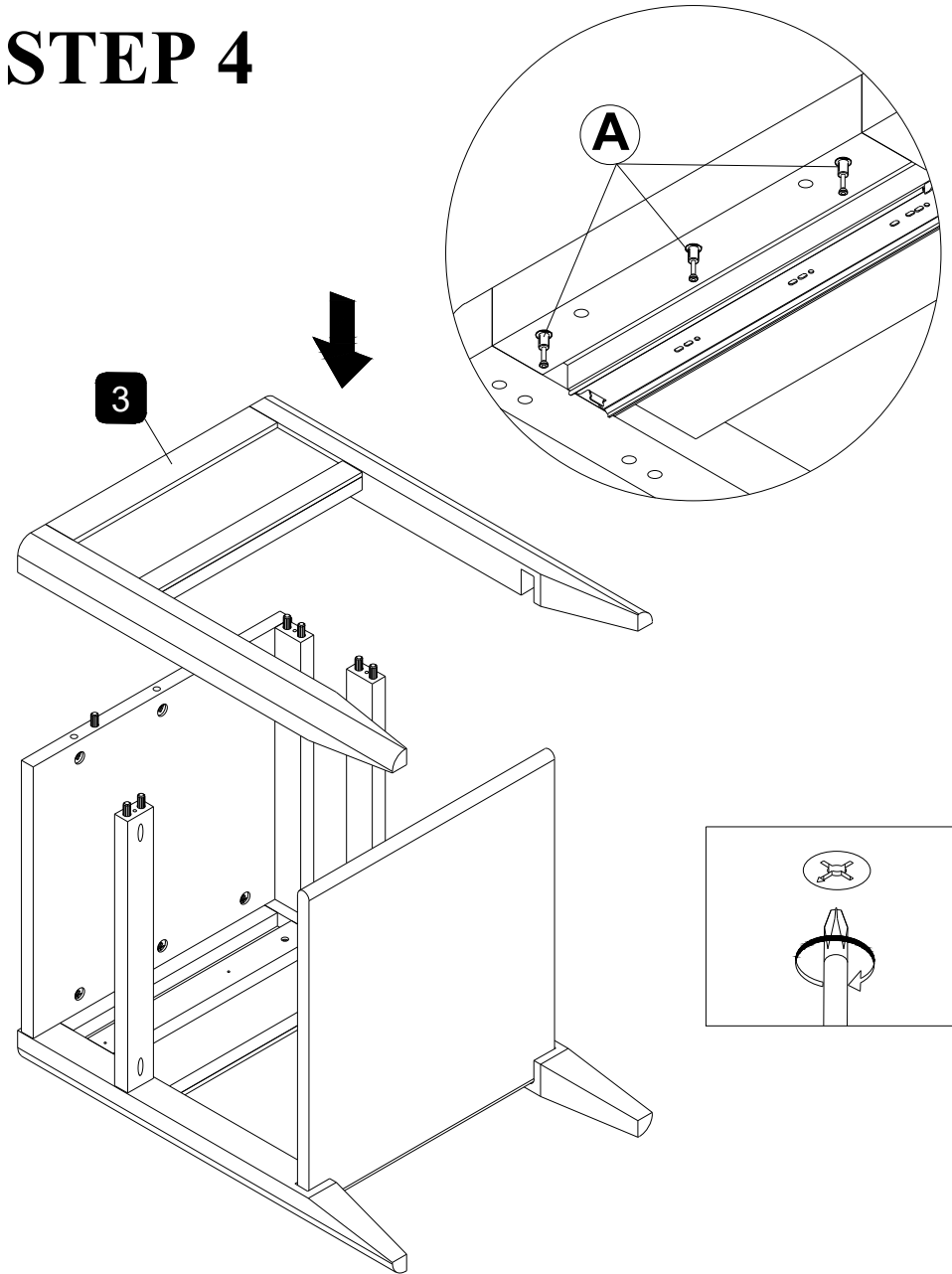

A X 3pcs

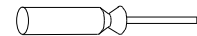

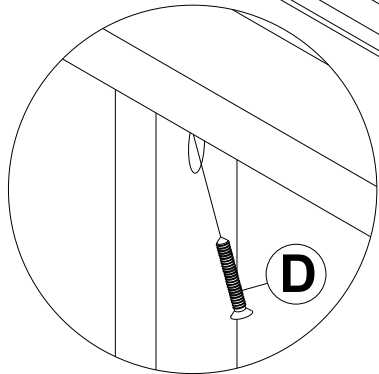
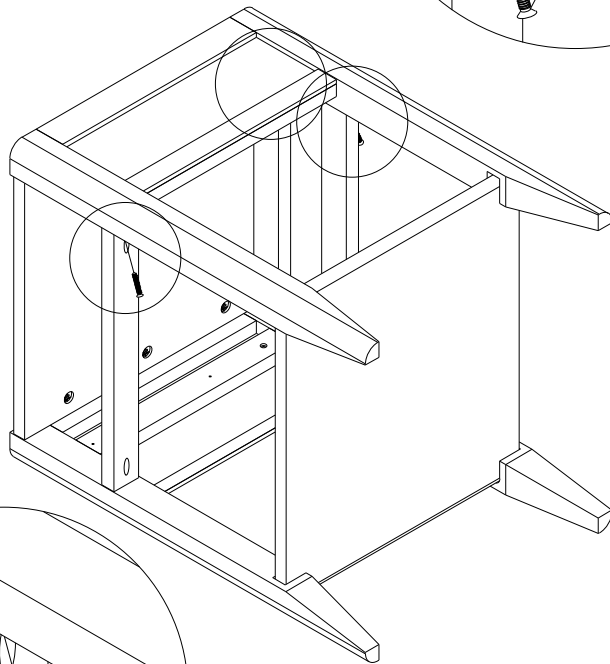
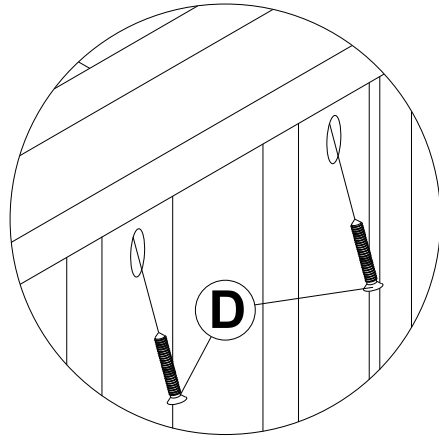

STEP 5

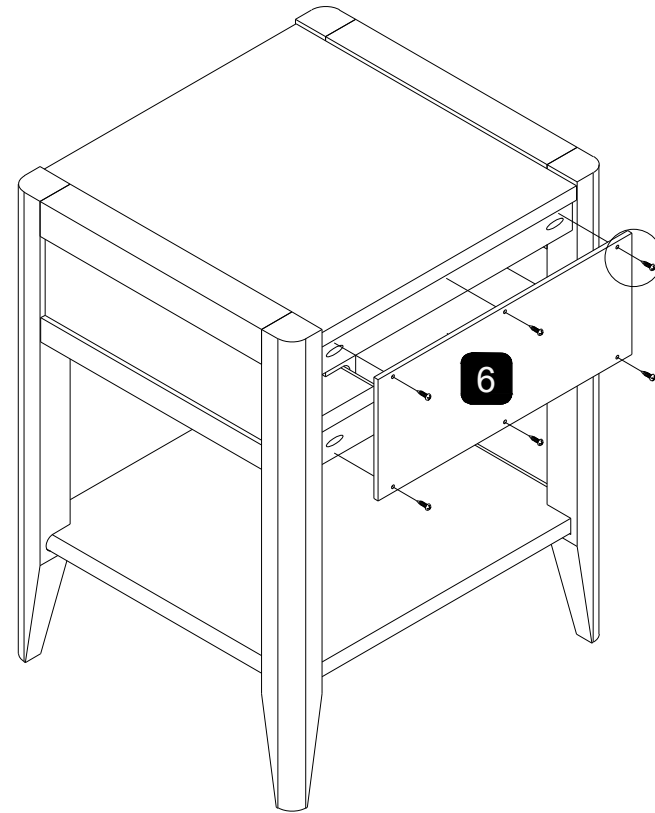
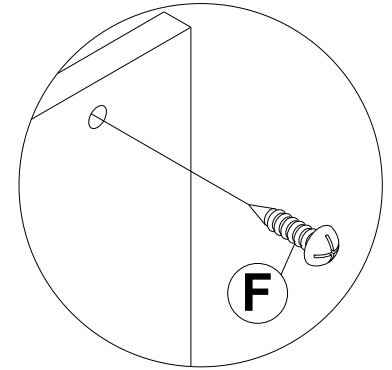

STEP 6

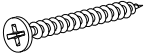



D X 3pcs

F X 6pcs

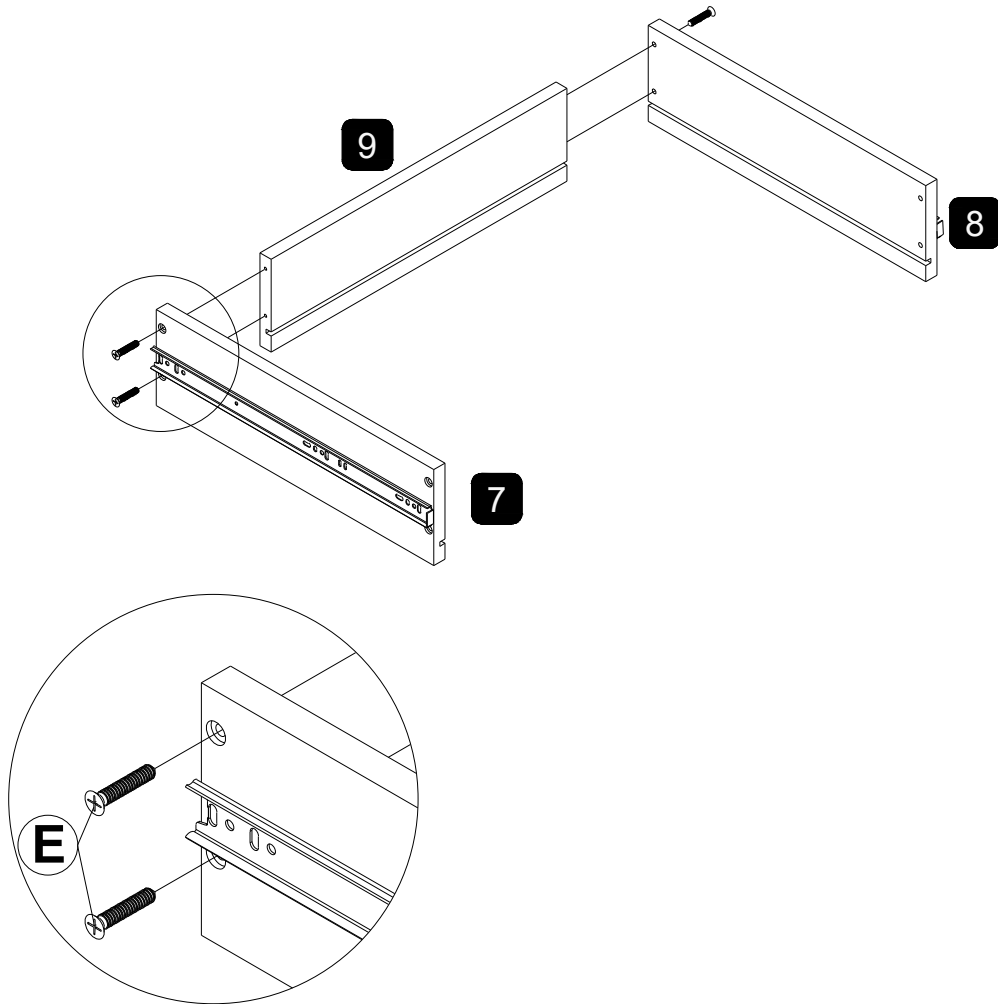
STEP 7

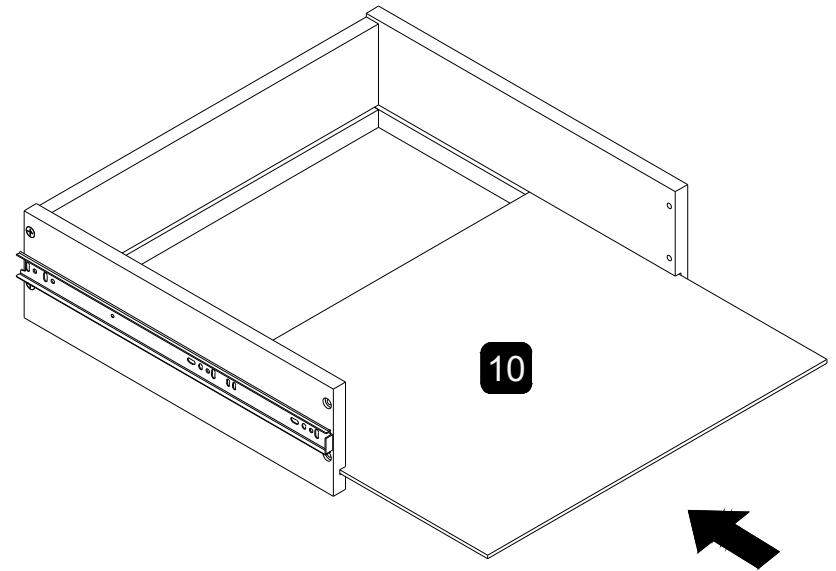

STEP 8



E X 4pcs

STEP 9

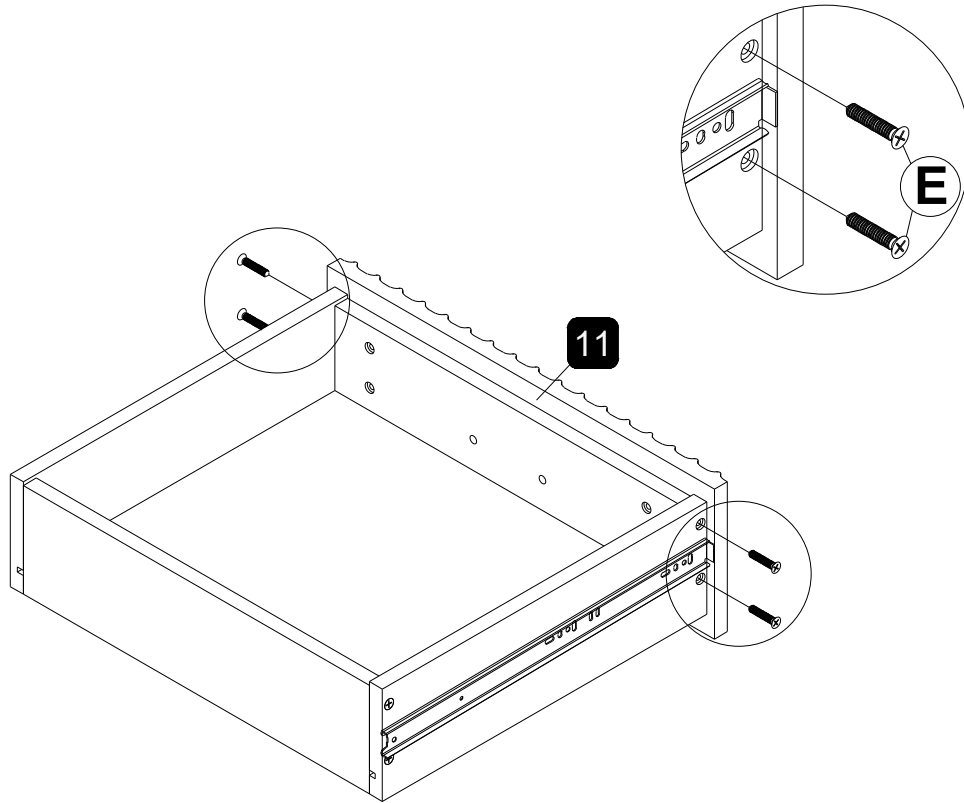

STEP 10

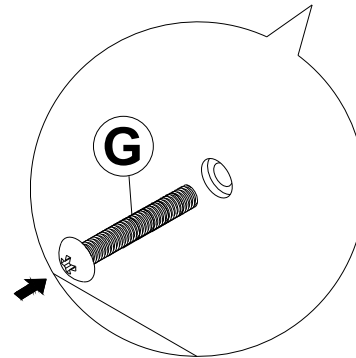
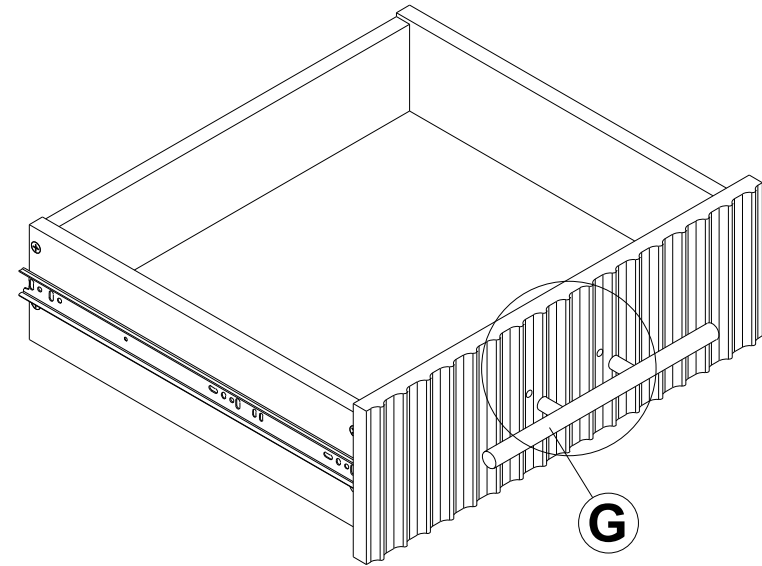

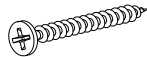

E X 4pcs

G X 1set

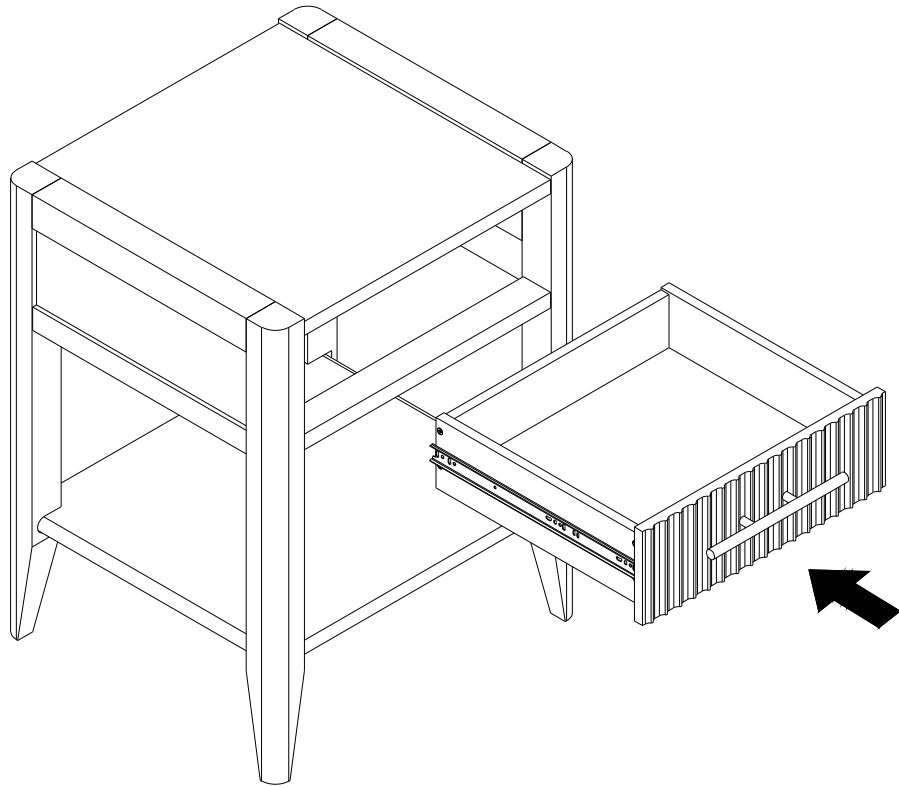
STEP 11

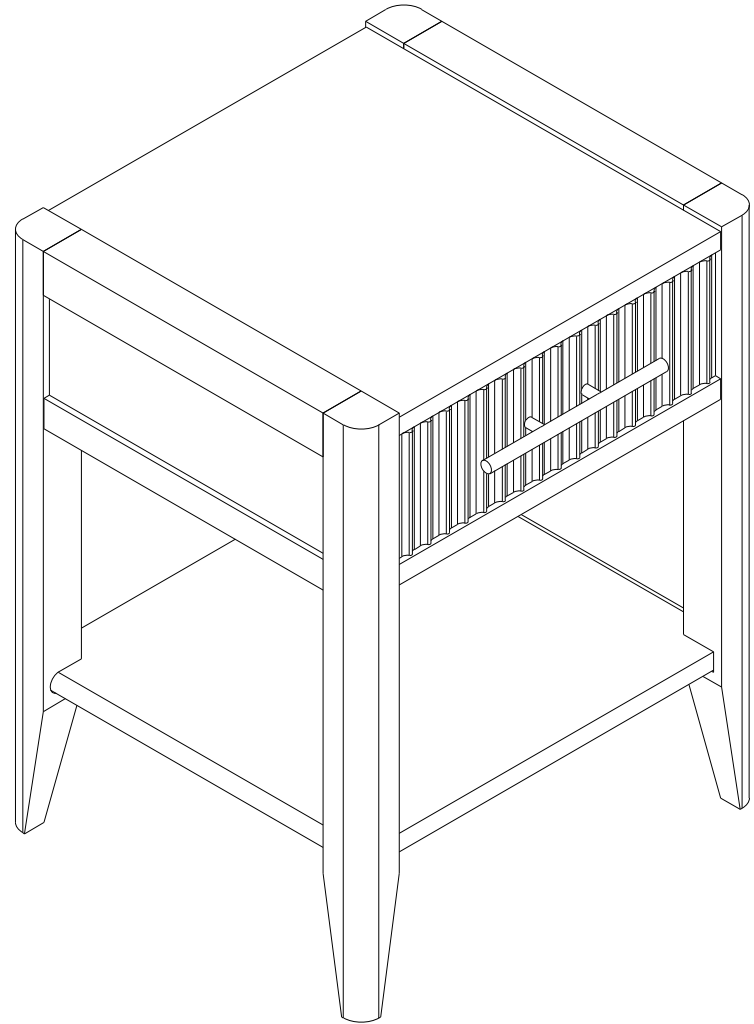

ASSEMBLY COMPLETE



ASSEMBLY INSTRUCTION

SW 8000-66D6D

REAR

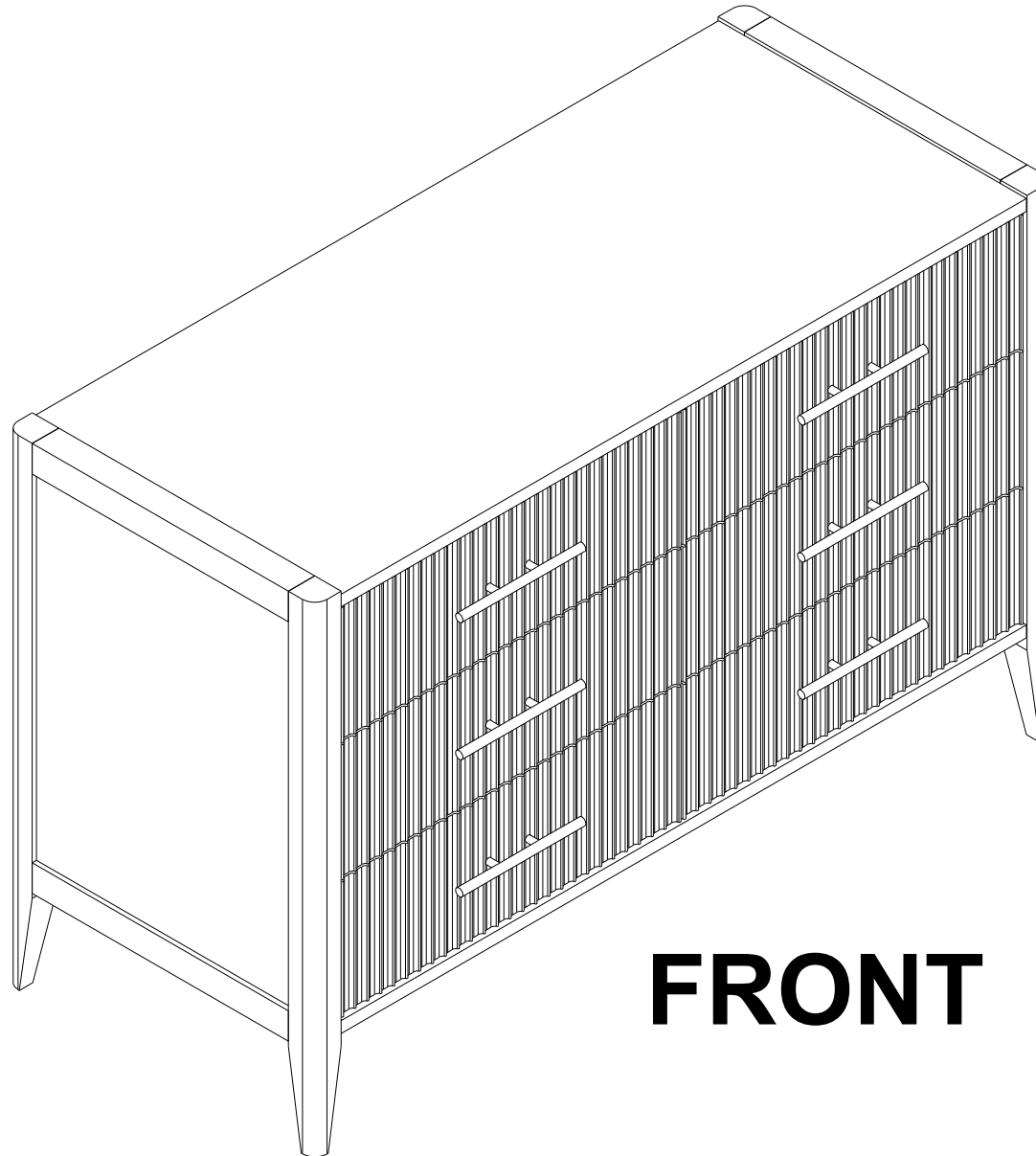



FRONT

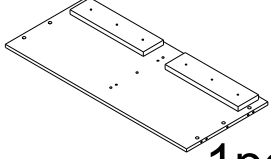
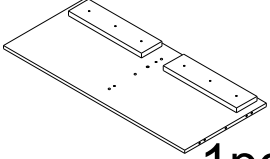
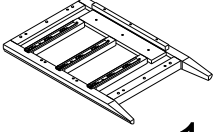
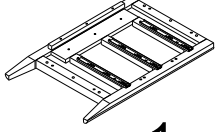
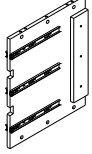
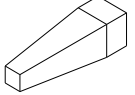
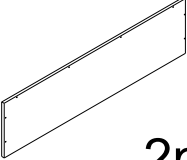
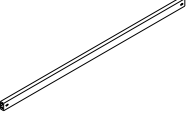
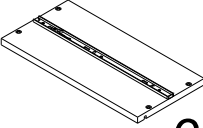
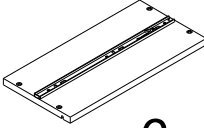
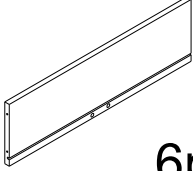
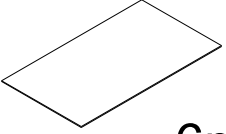
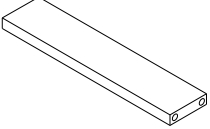
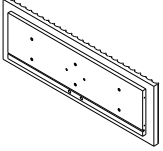

PART LIST

1 Top Panel  1pc	2 Bottom Panel  1pc	3 Side Panel(left)  1pc	4 Side Panel(right)  1pc	5 Division  1pc	6 Support Leg  1pc
7 Back Panel  2pcs	8 Support Rail  2pcs	9 Drawer Side Panel(left)  6pcs	10 Drawer Side Panel(right)  6pcs	11 Drawer Rear Panel  6pcs	12 Drawer Base Panel  6pcs
13 Drawer Support Rail  6pcs	14 Drawer Front Panel  6pcs				

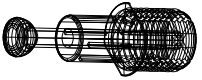
HARDWARE LIST

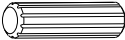
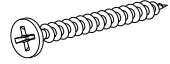
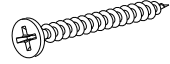
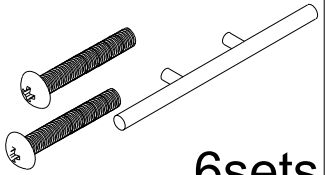
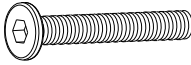
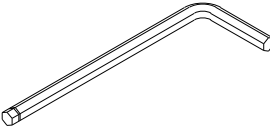
<p>A MINI FIX SPREADING BOLT 24MM</p>  <p>18pcs</p>	<p>B MINIFIX HOUSING Ø15*12MM</p>  <p>18pcs</p>	<p>C WOOD DOWEL M8*30MM</p>  <p>44pcs</p>	<p>D CSK SCREW M4*30MM</p>  <p>20pcs</p>	<p>E CSK SCREW M4*25MM</p>  <p>48pcs</p>	<p>F HANDLE</p>  <p>6sets</p>
<p>G JCBC M6 X 40MM</p>  <p>1pc</p>	<p>H M4 ALLEN KEY</p>  <p>1pc</p>				

STEP 1

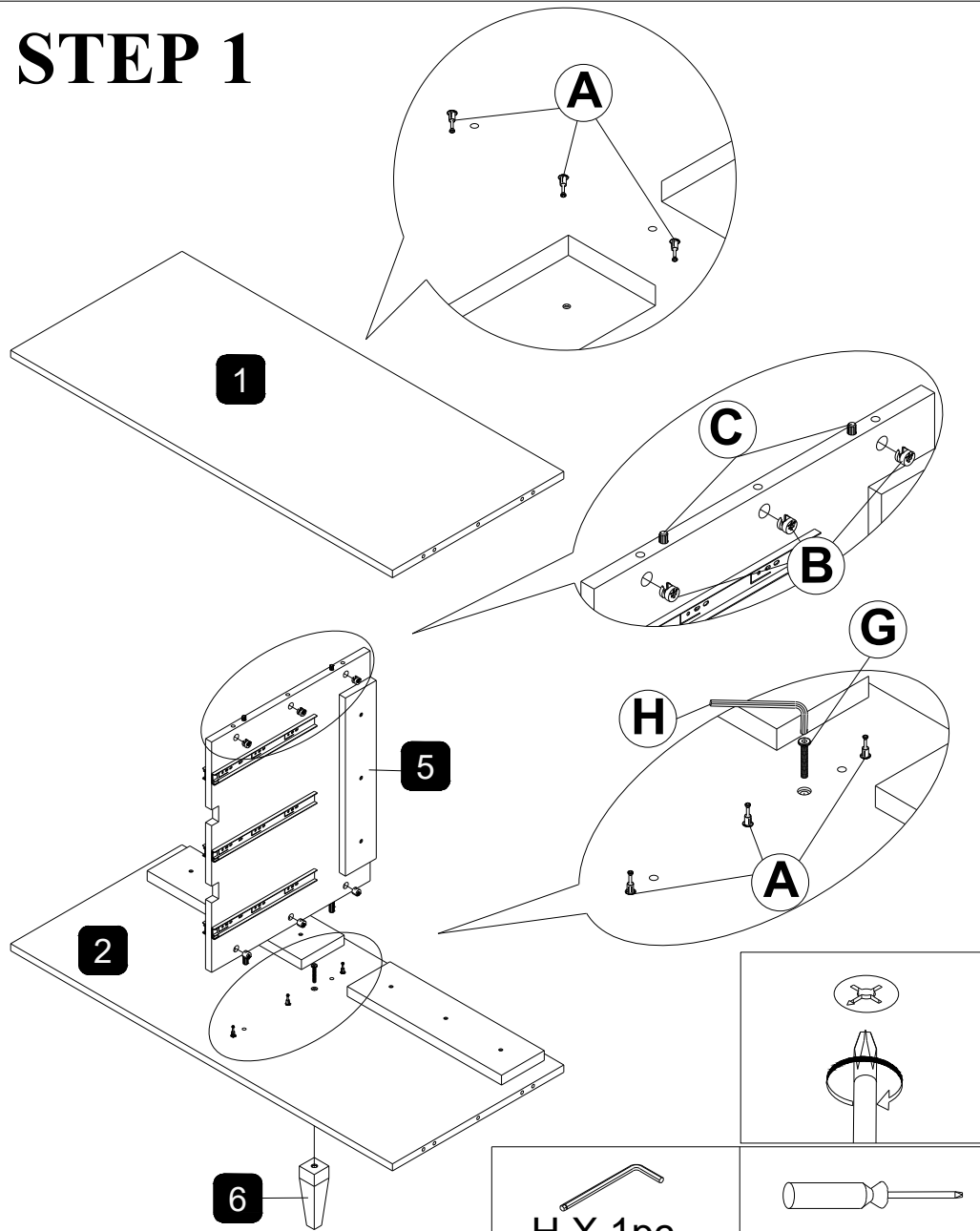

STEP 2

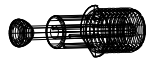
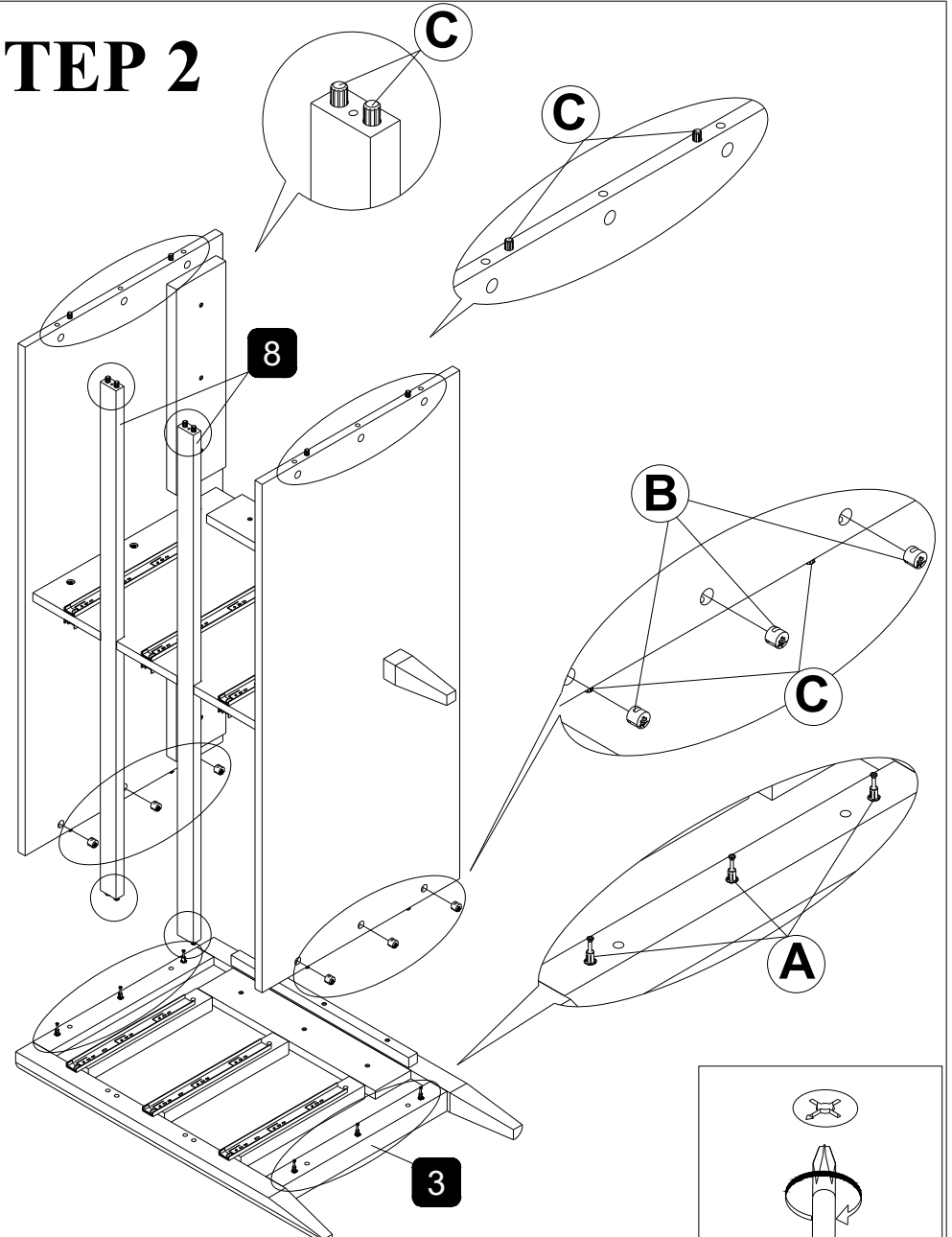

A X 6pcs



B X 6pcs

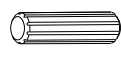

C X 4pcs



G X 1pc

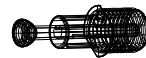

A X 6pcs



B X 6pcs

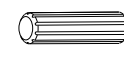

C X 16pcs

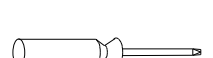

STEP 3

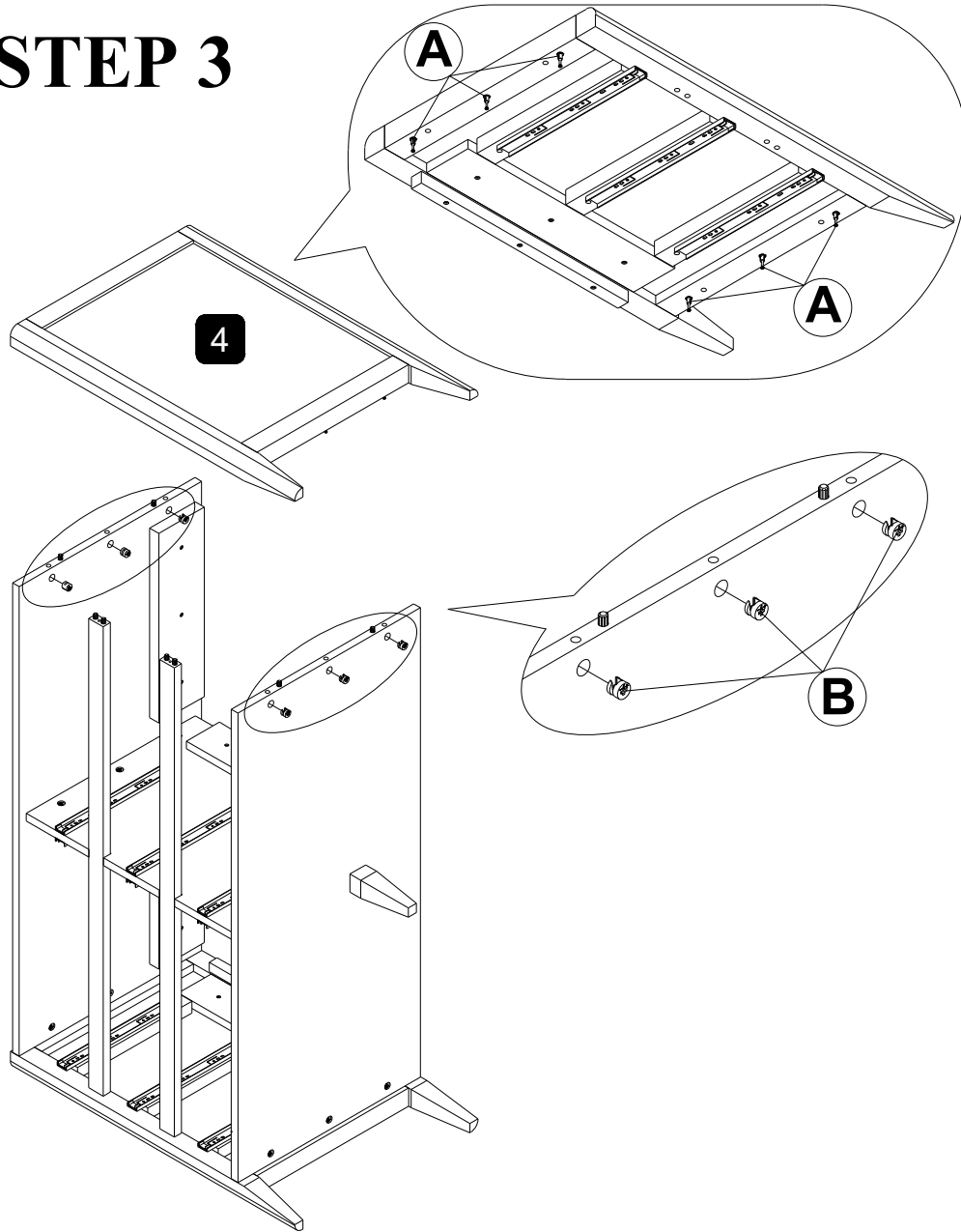

STEP 4

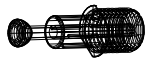
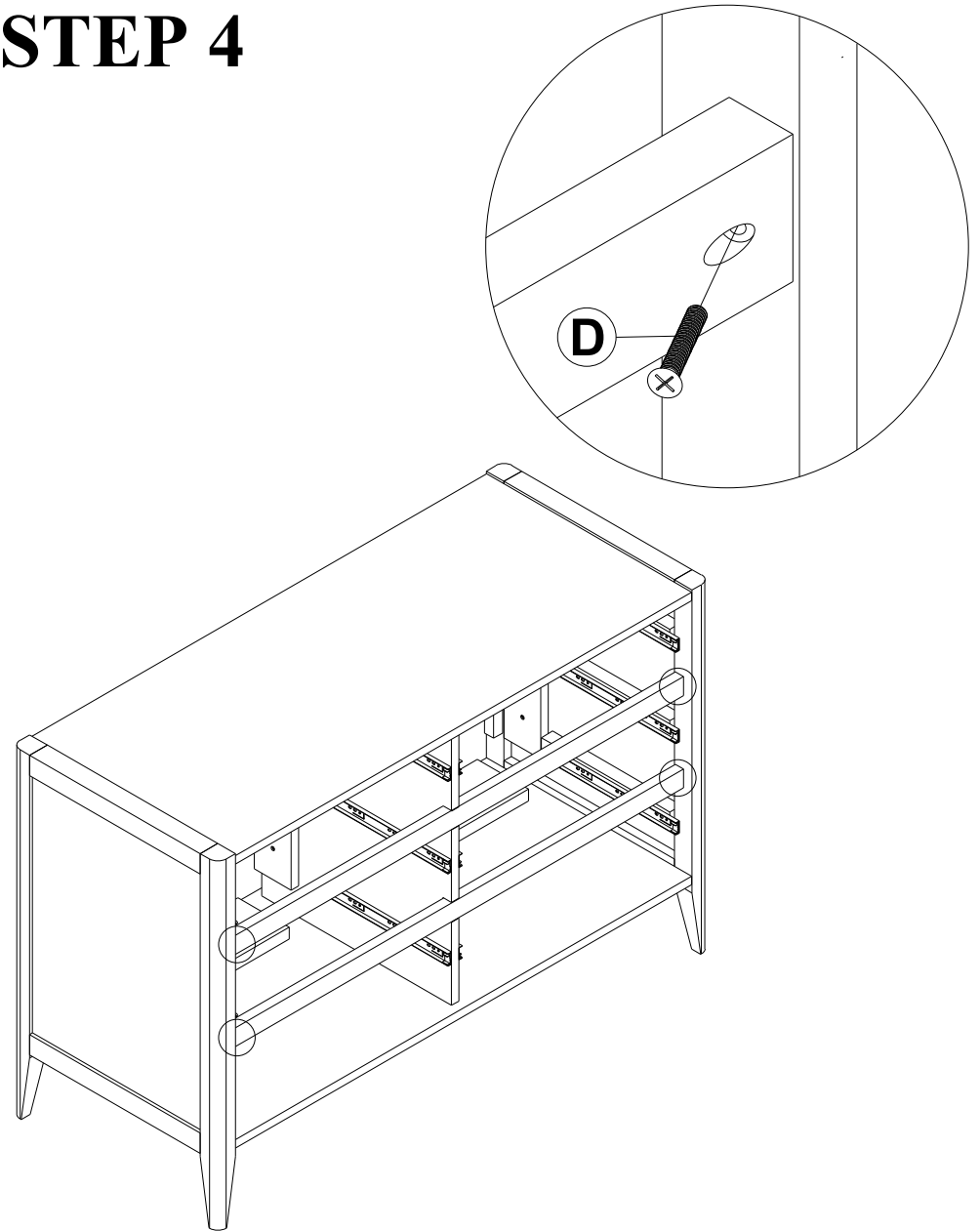

A X 6pcs



B X 6pcs

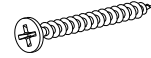

D X 4pcs

STEP 5

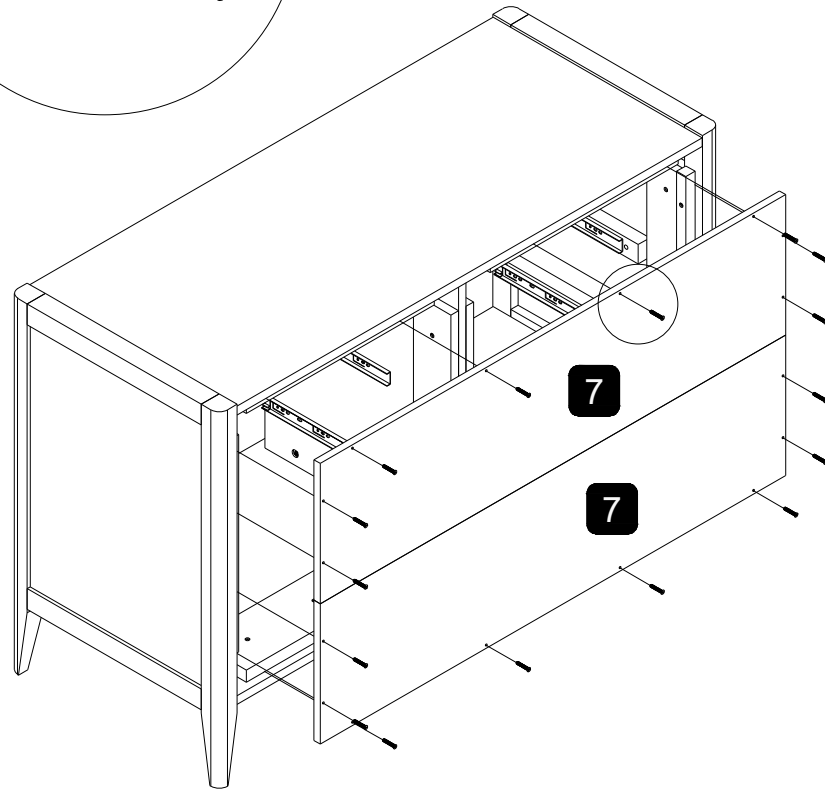
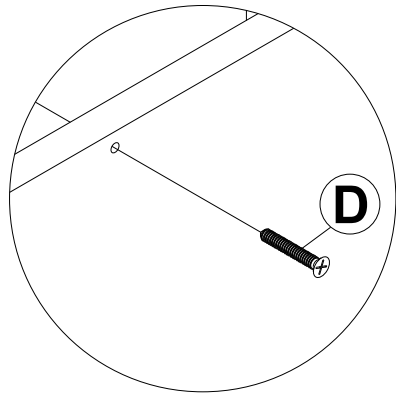

STEP 6

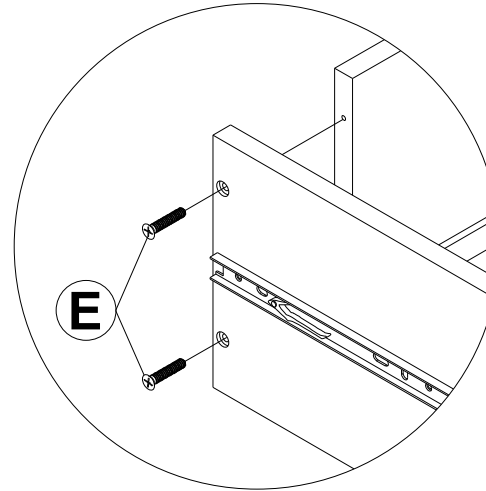

X 6

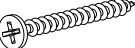
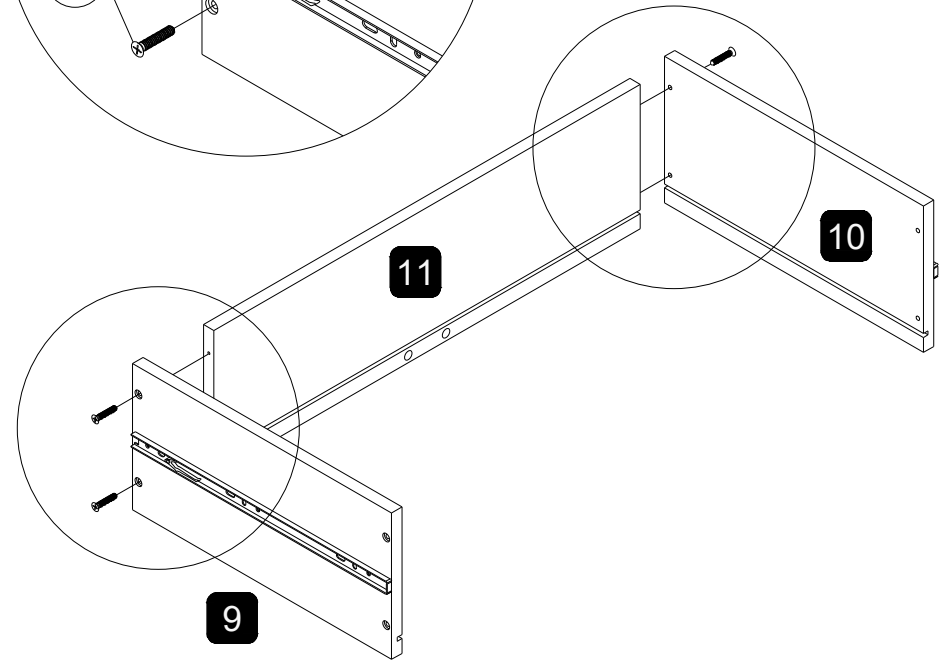

D X 16pcs

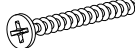

E X 24pcs

STEP 7

X 6

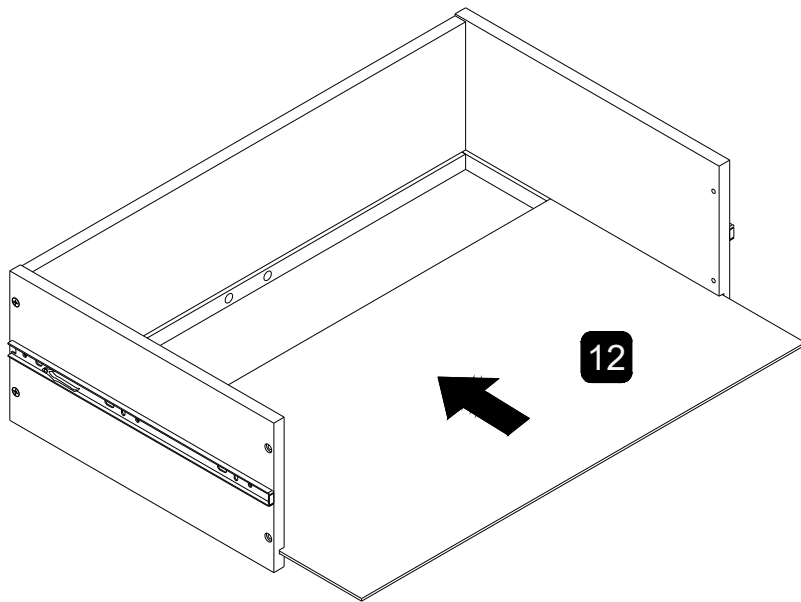

STEP 8

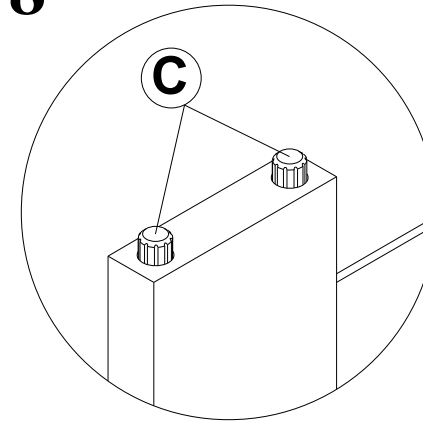

X 6

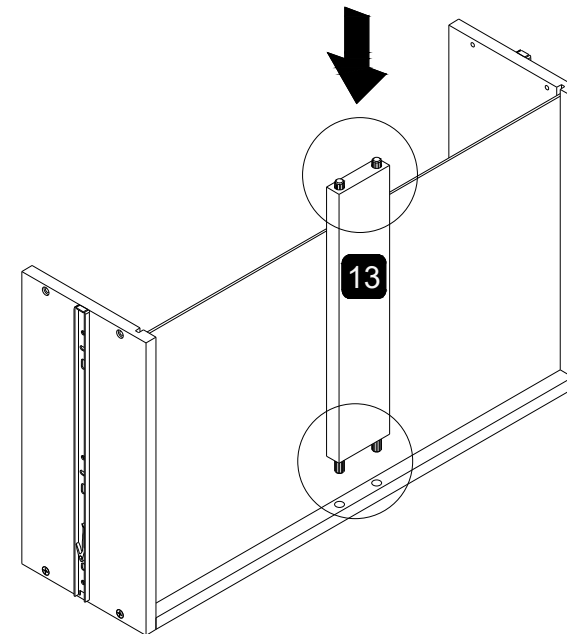

C X 24pcs

STEP 9

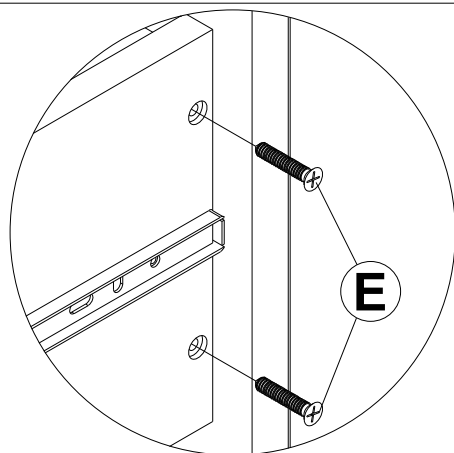

X 6

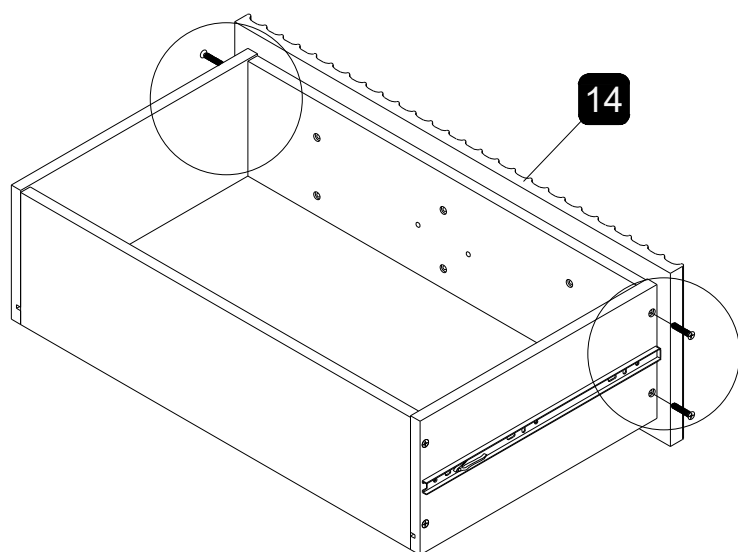

STEP 10

X 6

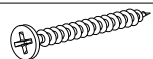
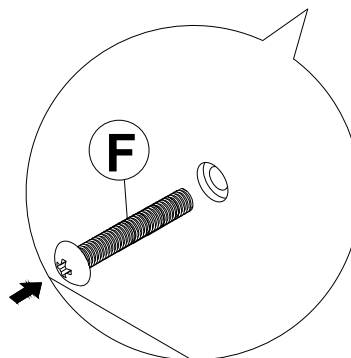
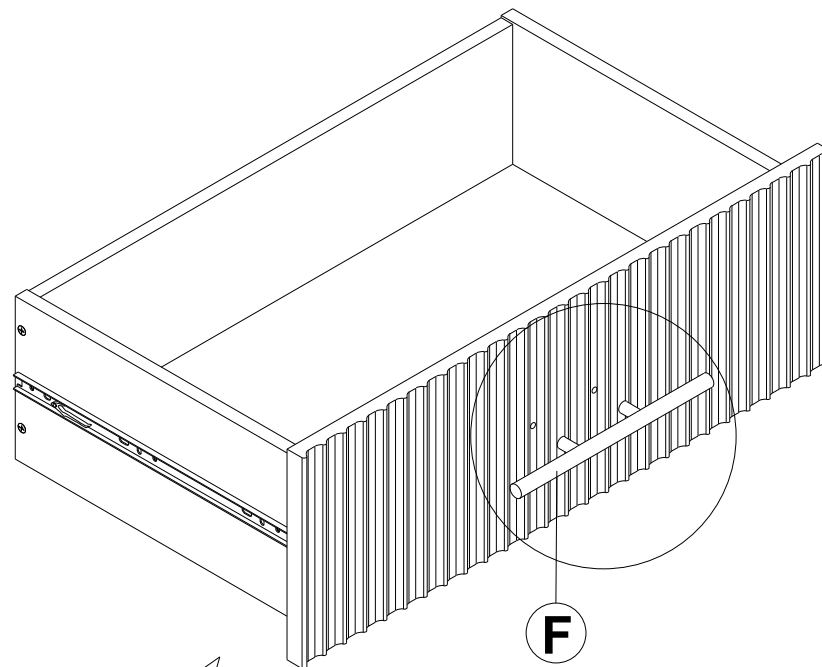

E X 24pcs



F X 6sets

STEP 11

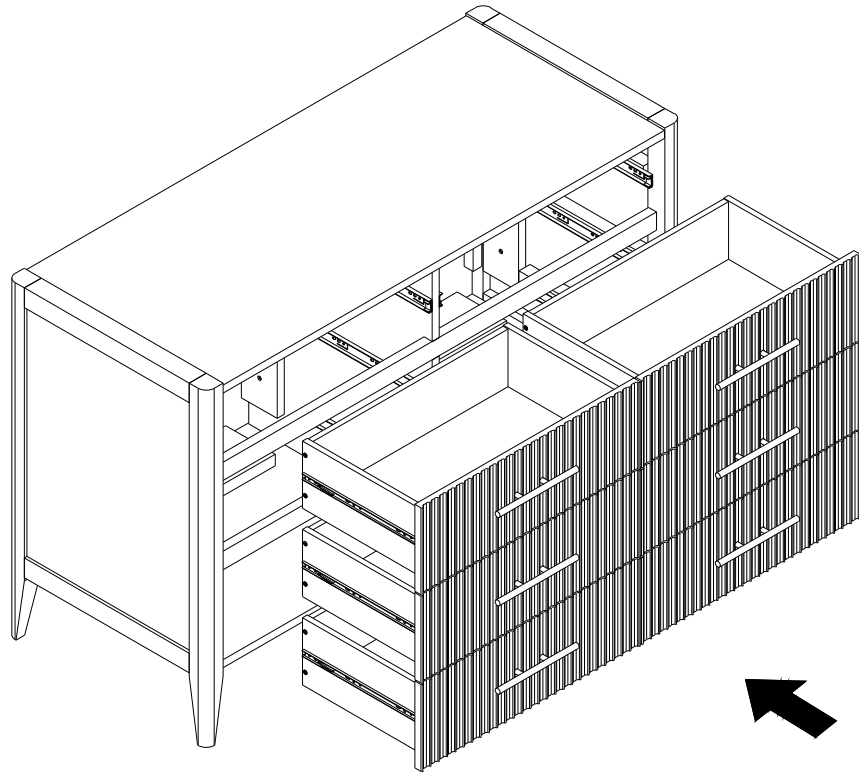

ASSEMBLY COMPLETE

CONTINUE TO ASSEMBLY
ANTI TIPPING KITS

