

# 0107 Queen Bed

## Assembly Instructions

W11-0622

### 1 Assembled View

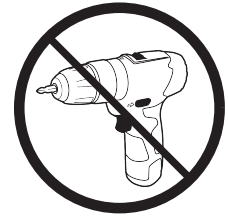
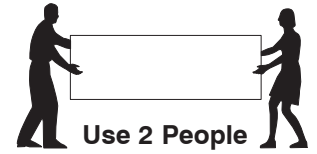
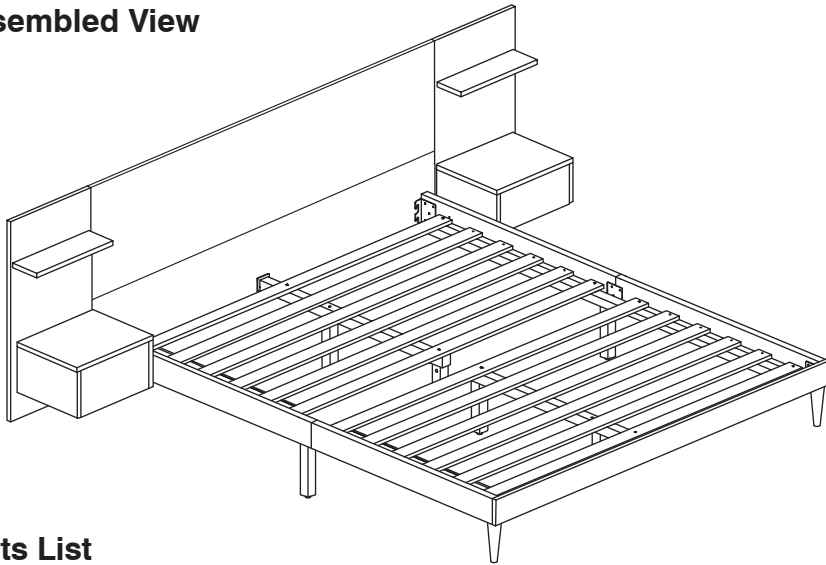

**Note:** Do not assemble using power tools. This can cause the bolts to be overtightened

### 2 Parts List

#### Parts in Box A:



**A** Headboard Panel (Upper) x 1

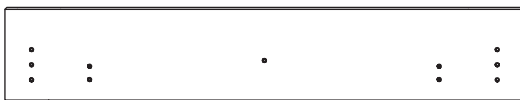

**B** Headboard Panel (Lower) x 1



**C**

Support Bar x 2

#### Parts in Box B:



**D** Footboard Panel x 1

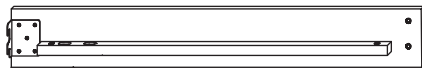

**E** Side Rail (Left Hand) x 2



**F** Side Rail (Right Hand) x 2

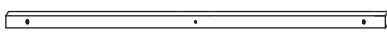

**G** Long Support x 2



**H**

Post x 2



**J**

Support Leg x 6

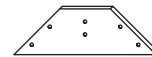

**K** Support Panel x 2

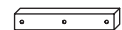

**L** Support Bar x 2

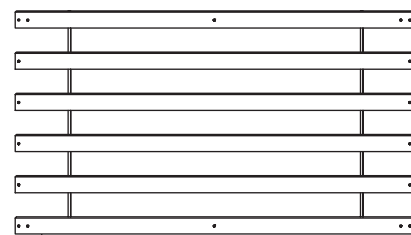

**M** Set of Bed Slats x 2

# 0107 Queen Bed

## Assembly Instructions

W11-0622

### 3 Parts List

#### Parts in Box C:

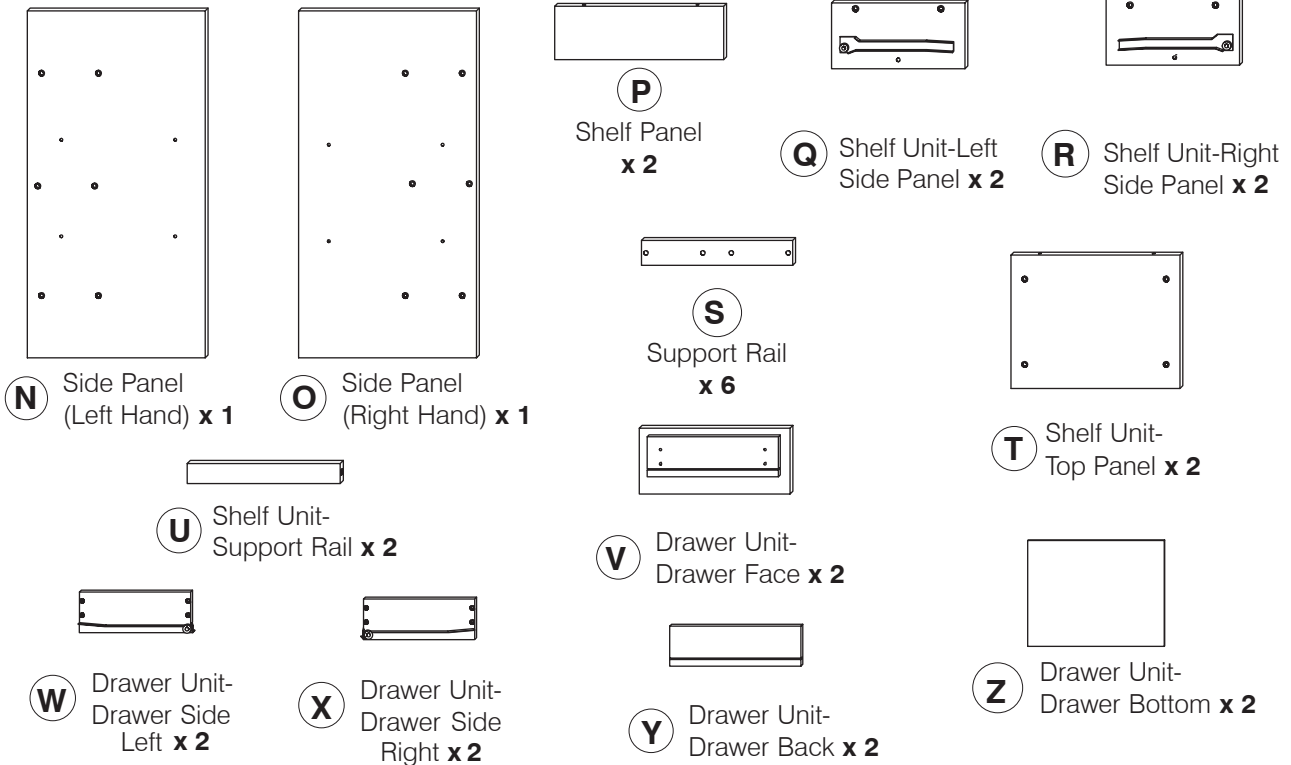

### 4 Hardware List

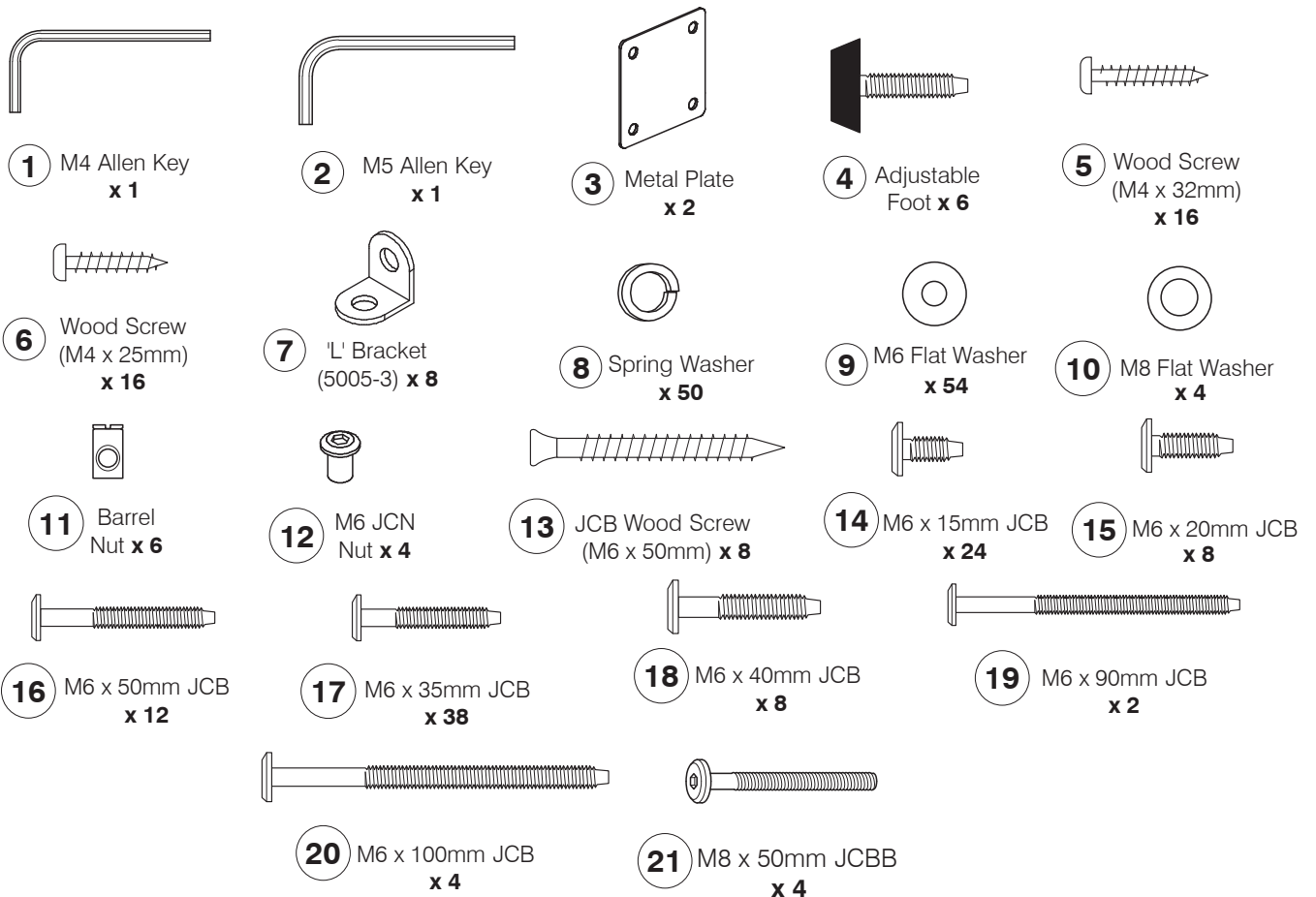

# 0107 Queen Bed

## Assembly Instructions

WII-0622

- 5** Assemble the Drawer Sides (W) to the Drawer Back (Y). Make sure the small wheels on the Drawer Sides (X) are next to the Drawer Back (Y).

x2

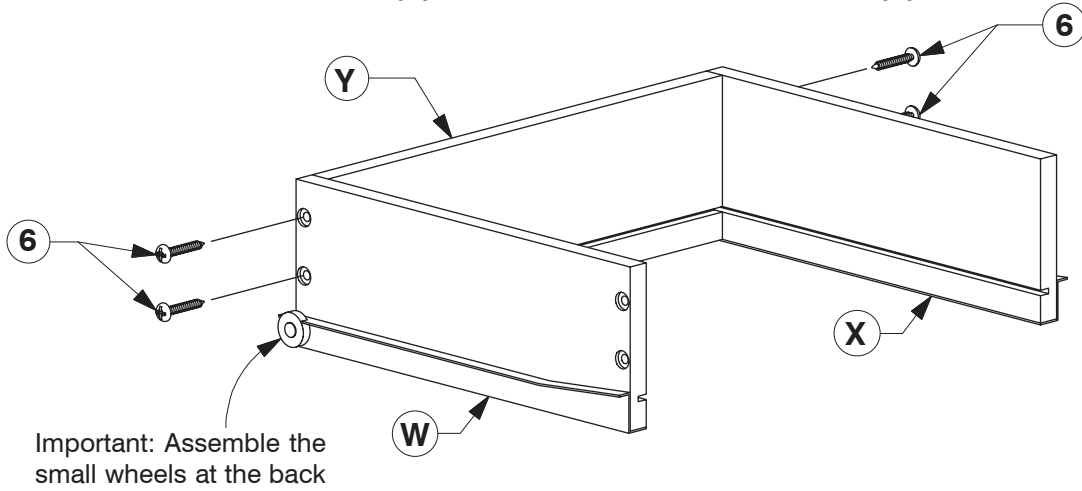

- 6** Slide the Drawer Bottom (Z) into the groove on the Drawer Sides (W & X).

x2

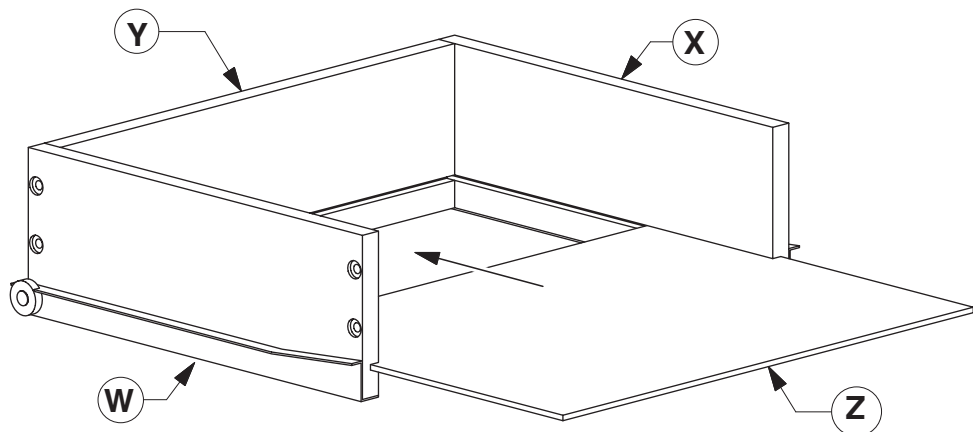

- 7** Assemble the Drawer Face (V) to the Drawer Sides (W & X).

x2

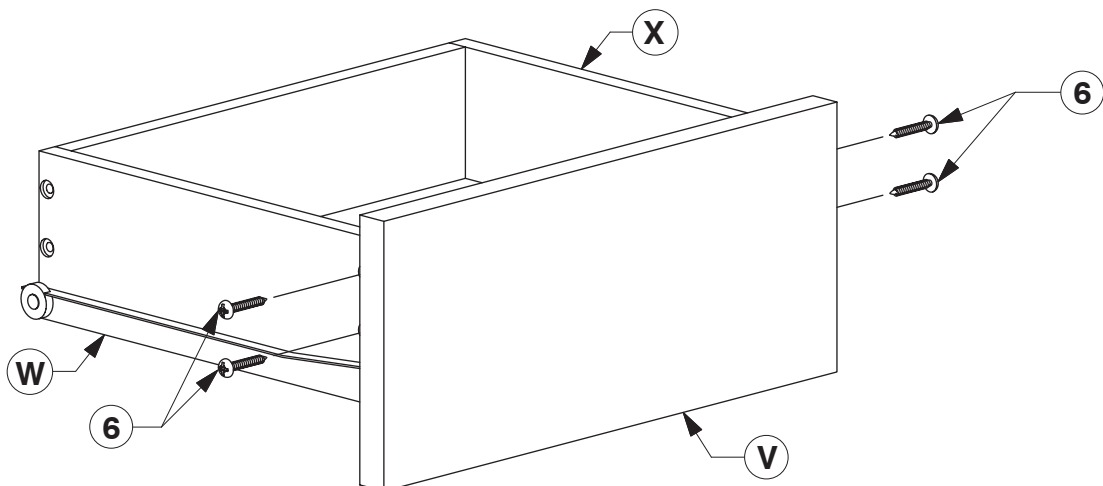

# 0107 Queen Bed

## Assembly Instructions

W11-0622

- 8** Fit 'L' Bracket to the Shelf Unit- Top Panel (T).

x2

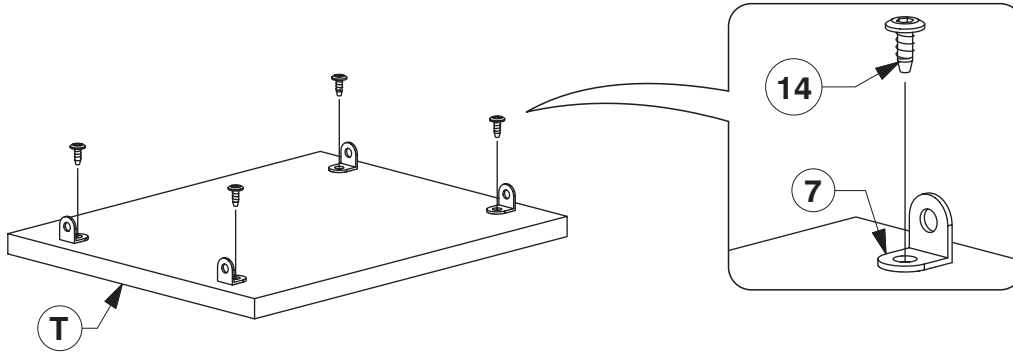

- 9** Assemble the Left and Right Shelf Unit.

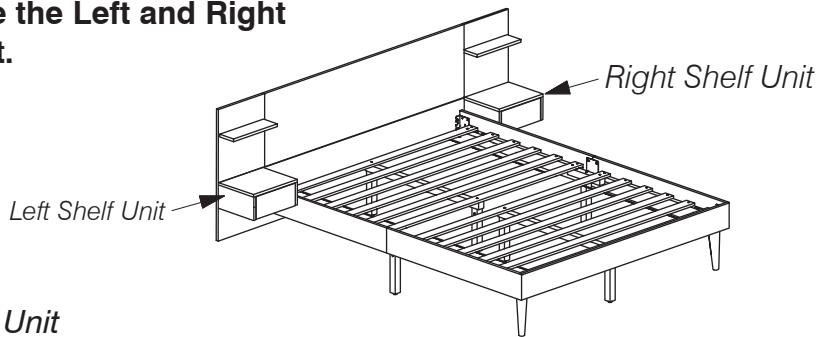

Left Shelf Unit

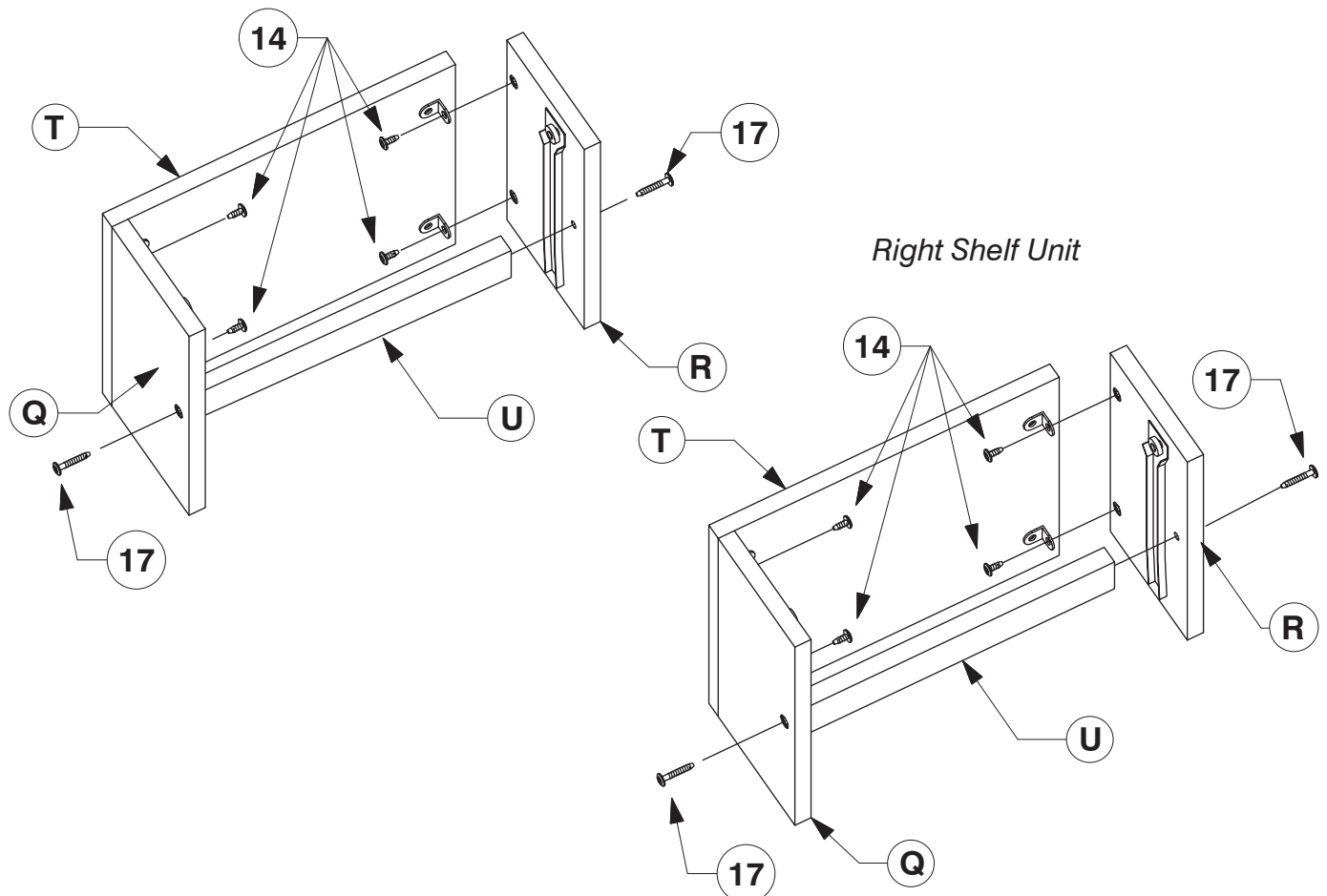

# 0107 Queen Bed

## Assembly Instructions

W11-0622

### 10 Assemble the Shelf Unit to the Side Panel (O & N).

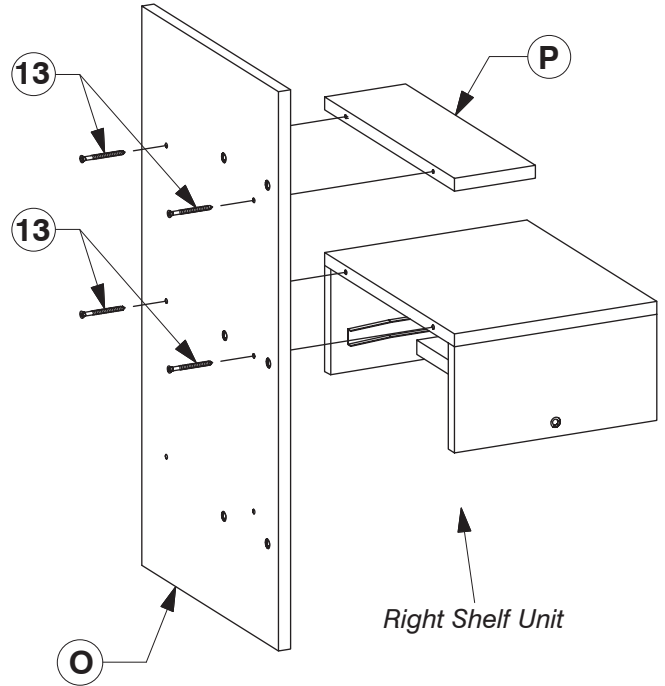
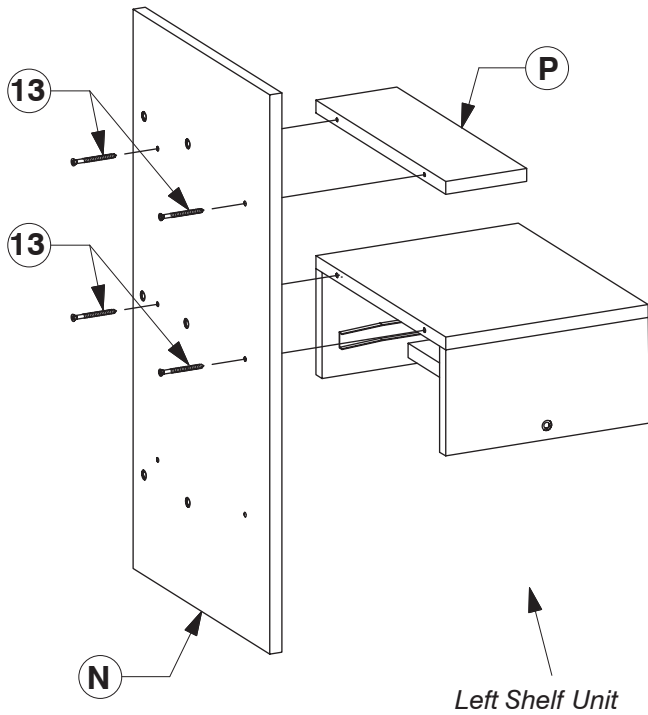

### 11 Fit the Adjustable foot to the bottom of the Support Leg (J).

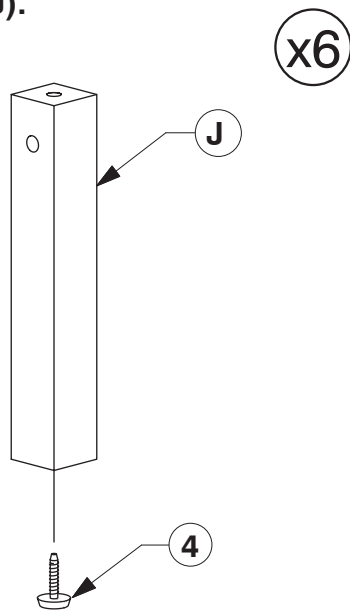

### 12 Fit the Support Bar (L) to the Support Leg (J).

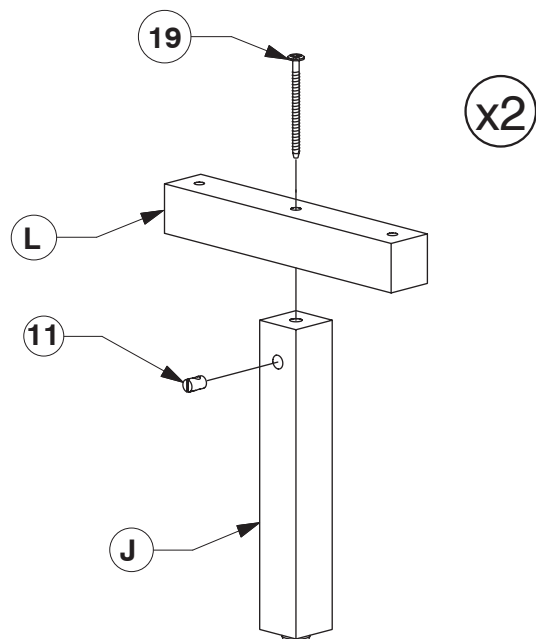

# 0107 Queen Bed

## Assembly Instructions

WII-0622

- 13** Fit the Post (H) to the Support Panel (K).

x2

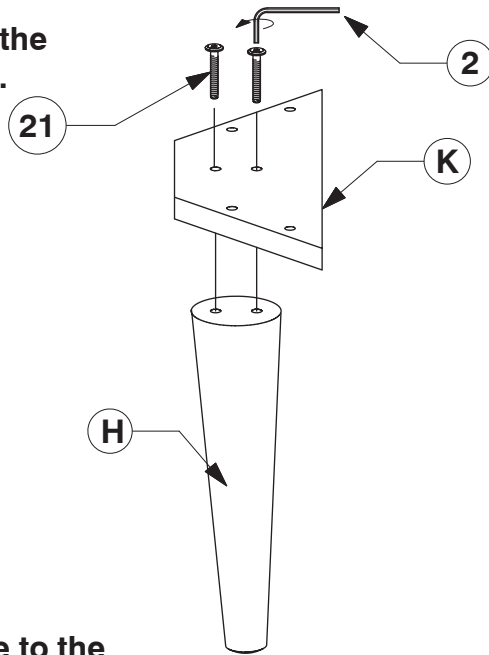

- 14** Fit the Metal Plate to the Side Rail (E & F).

x2

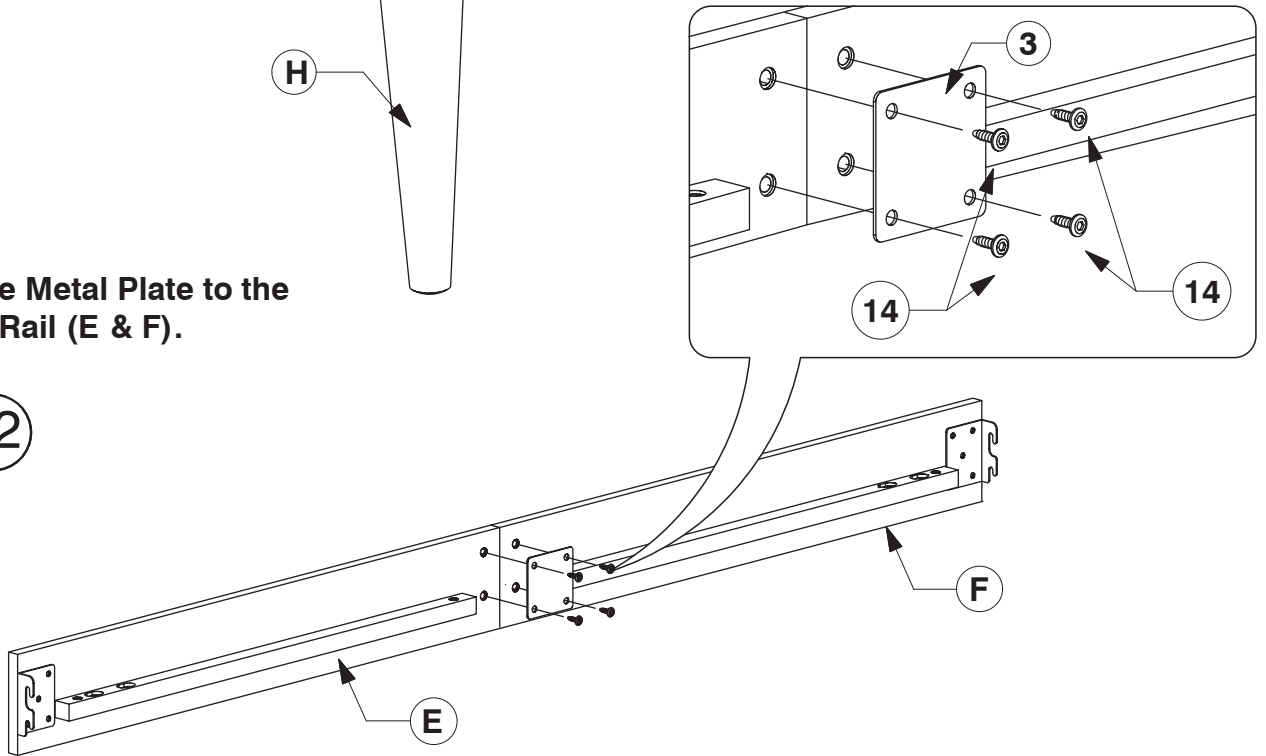

- 15** Assemble the Side Rail (F) to the Support Panel (K).

x2

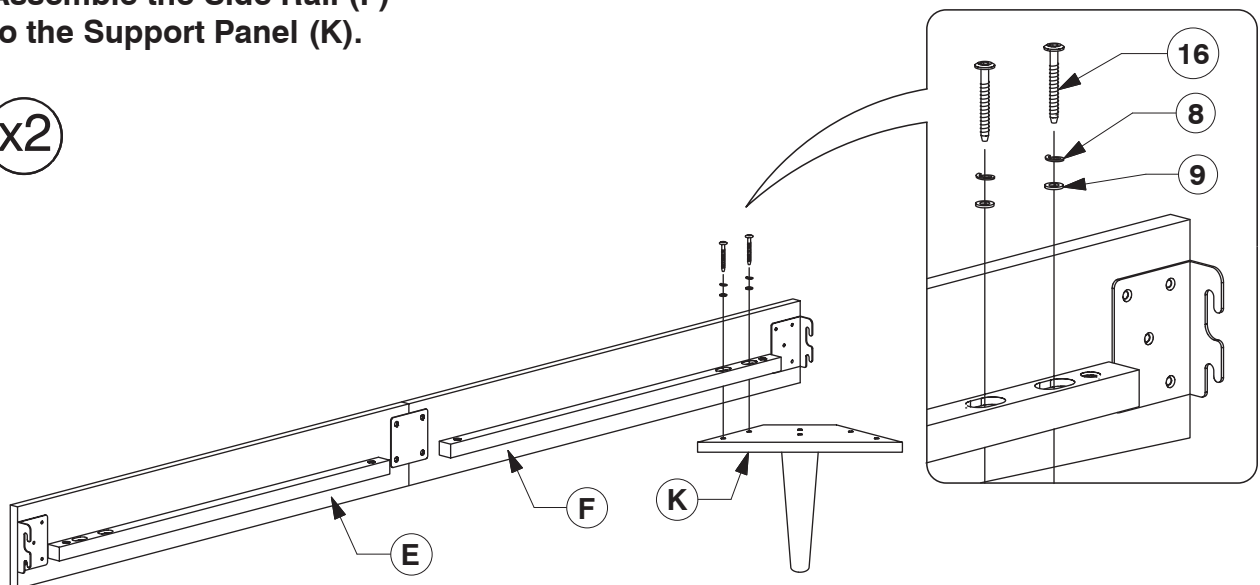

# 0107 Queen Bed

## Assembly Instructions

WII-0622

- 16** Assemble the Side Rail (E & F) to the Headboard (B) & Footboard (D).

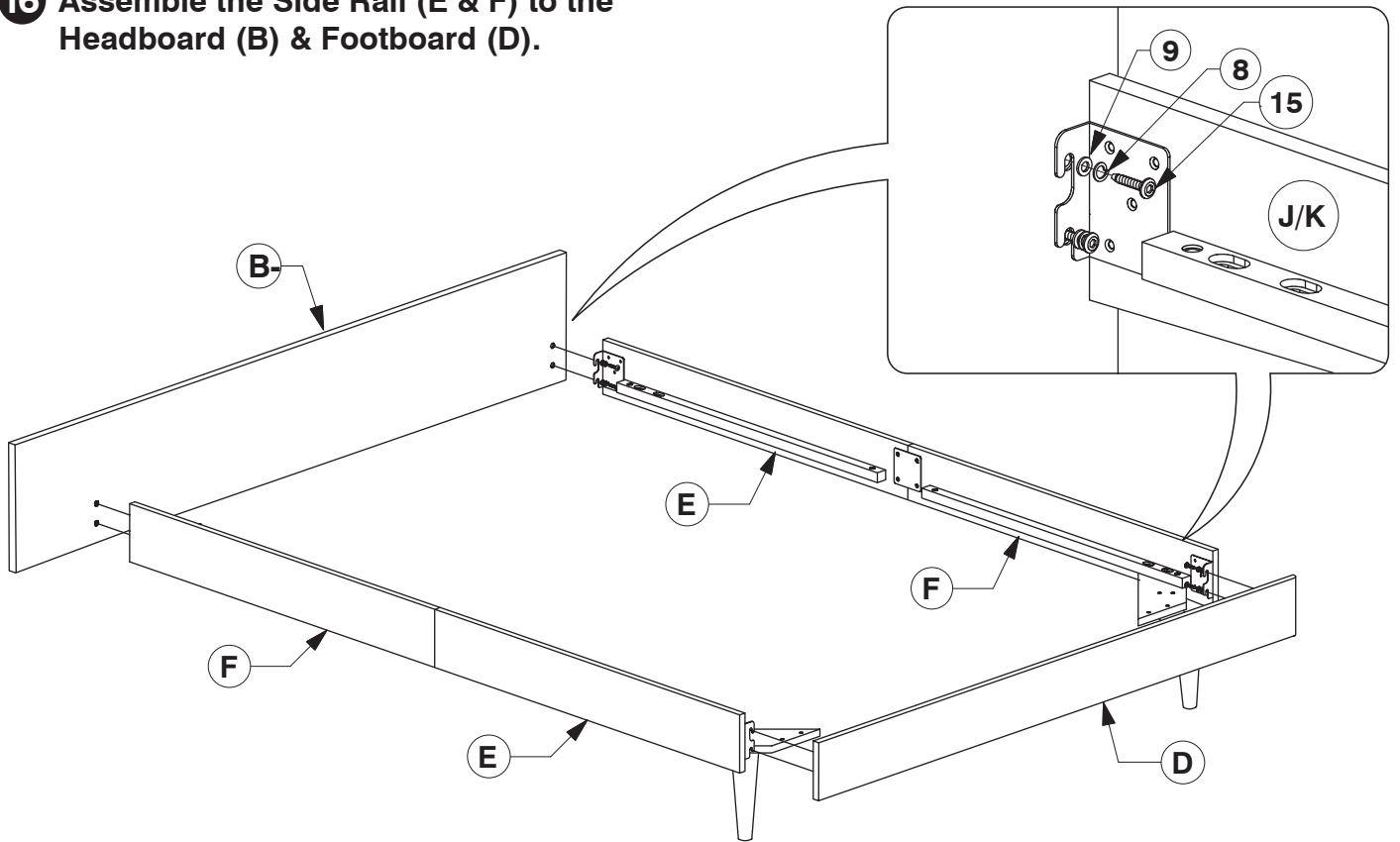

- 17** Fit the Slats (M) to the Long Support (G) & Support Leg (J) .

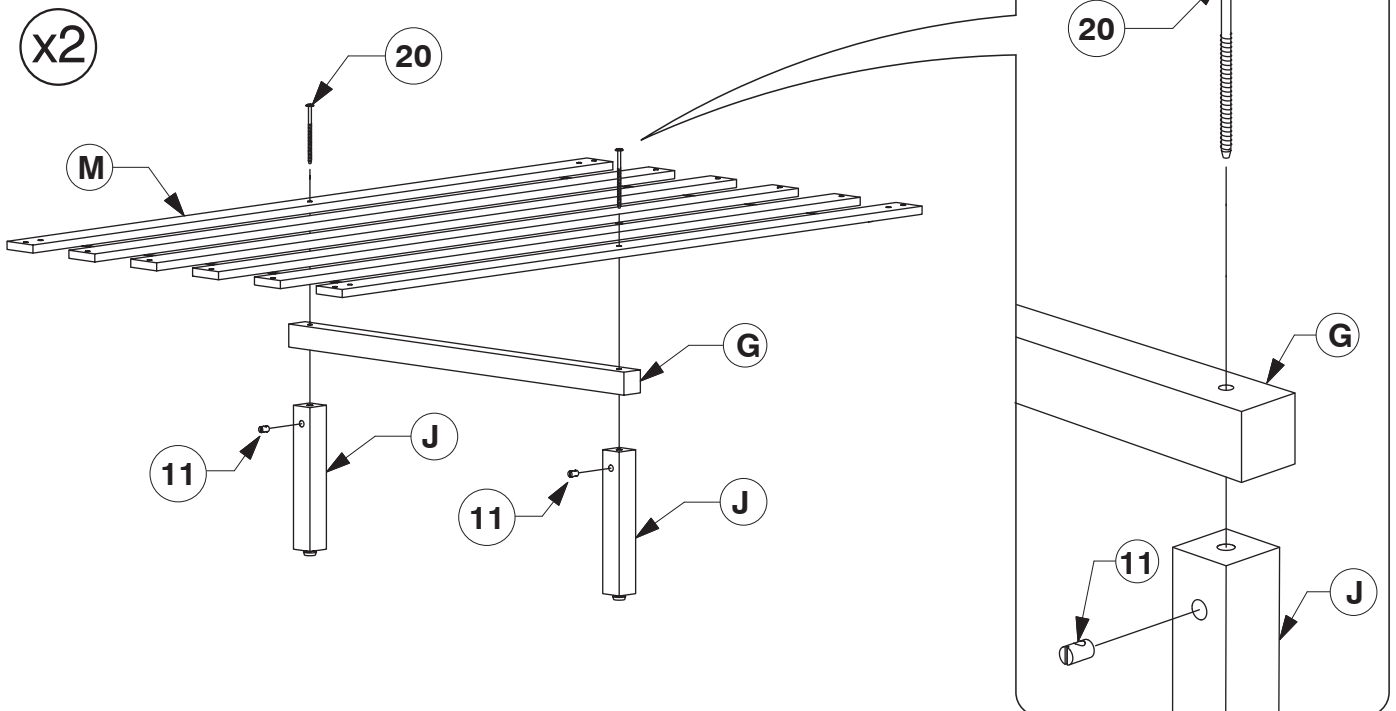

# 0107 Queen Bed

## Assembly Instructions

WII-0622

**18** Bolt the Bed Slat (M) to the Side Rail (F & E).

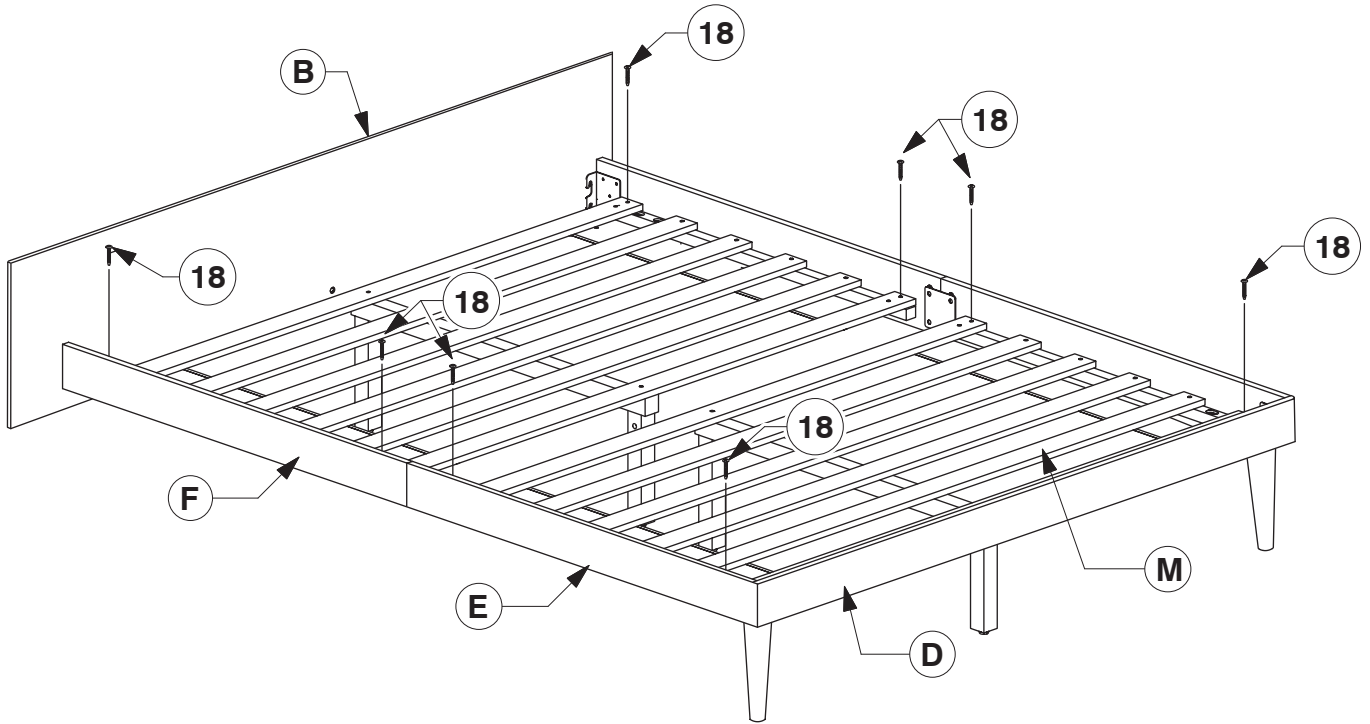

**19** Fit the Support Bars (L) in place.

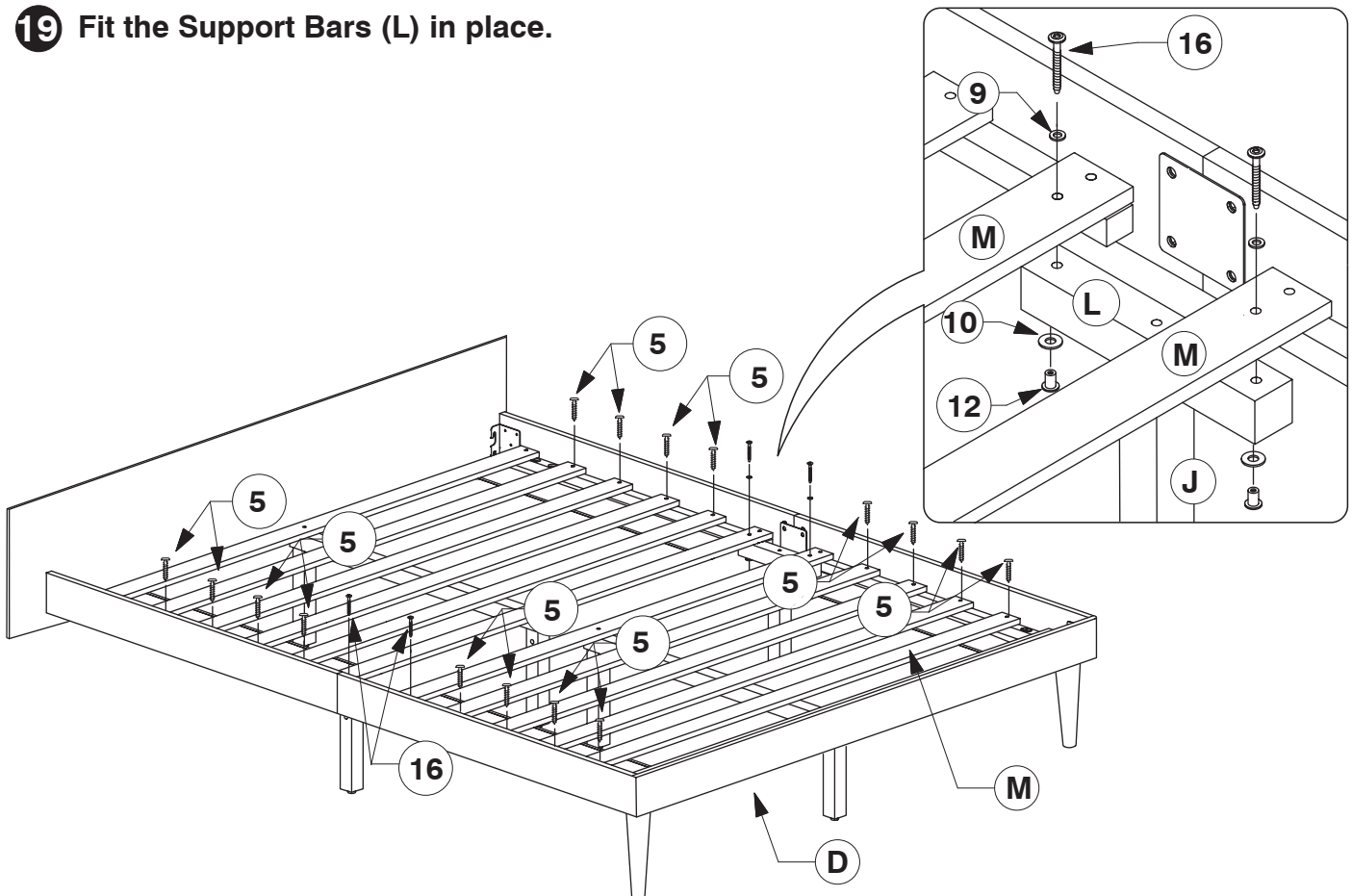



# 0107 Queen Bed

## Assembly Instructions

WII-0622

**20** Assemble the Headboard Panel- Upper (A) to the Support Bars (C).

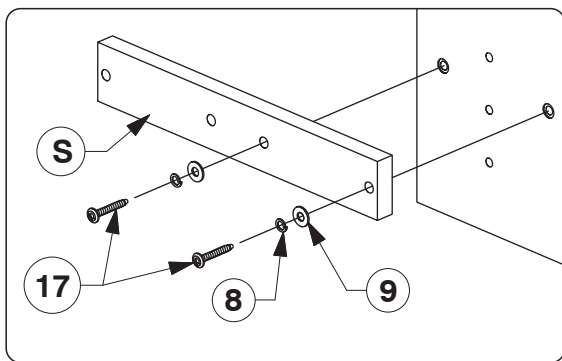
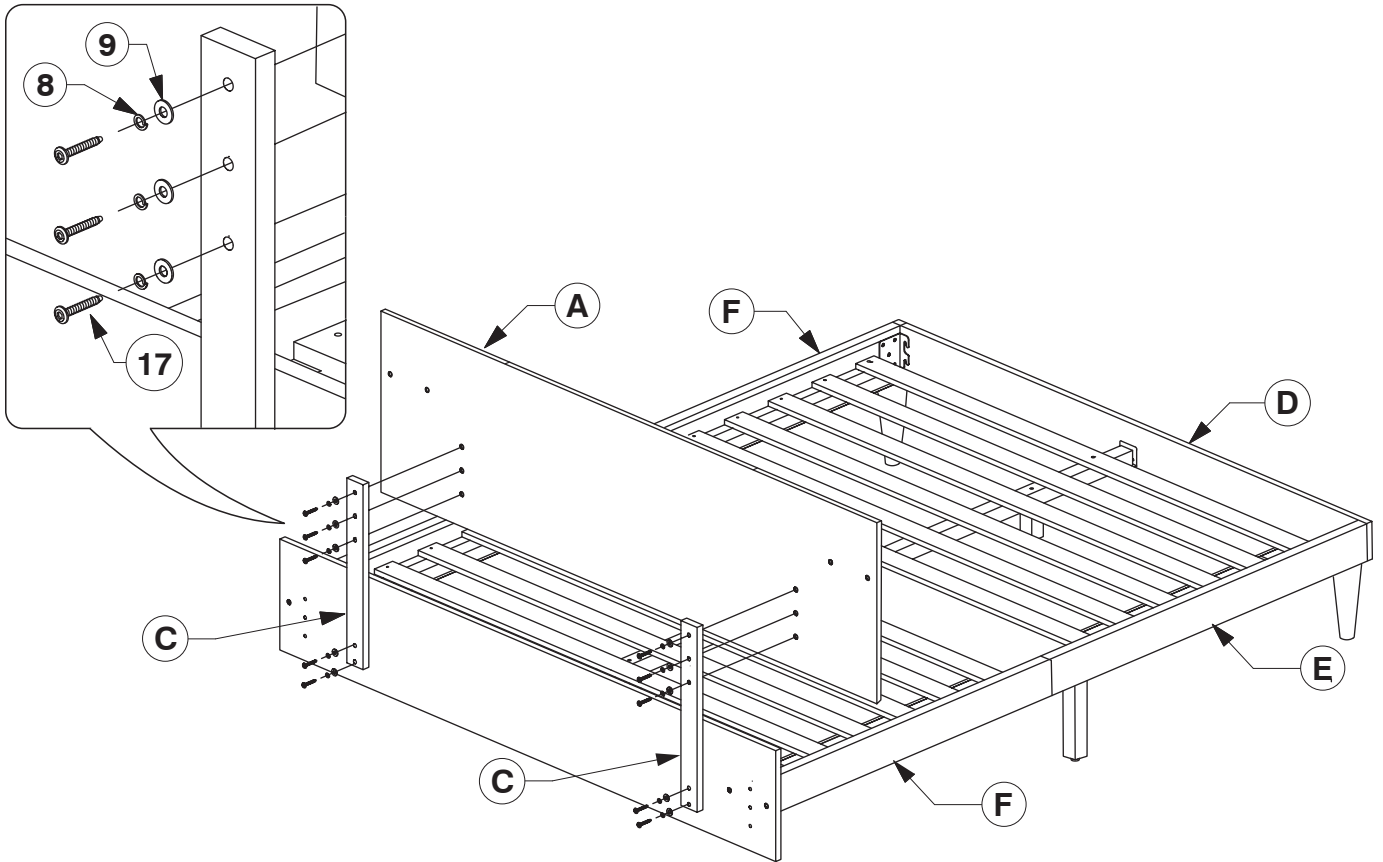

**21** Fit the Support Rail (M) with JCB on both sides.

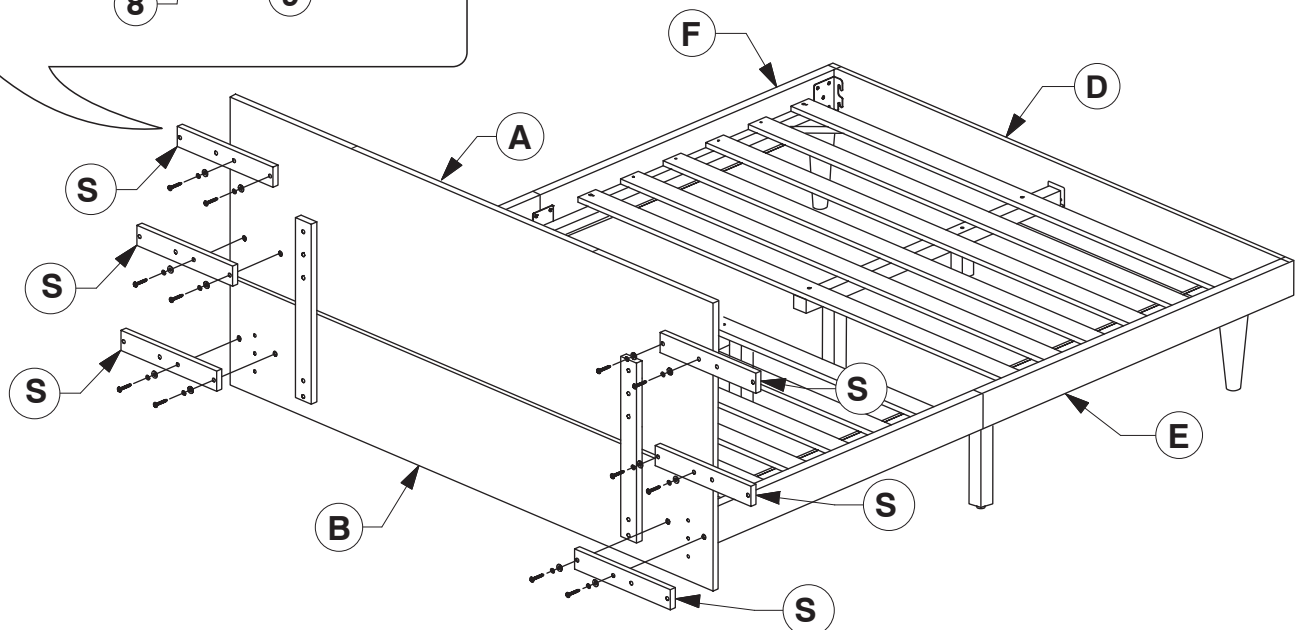

# 0107 Queen Bed

## Assembly Instructions

WII-0622

**22** Assembled the Side Panel (N & O) to the Headboard (A) with Support Rail (S).

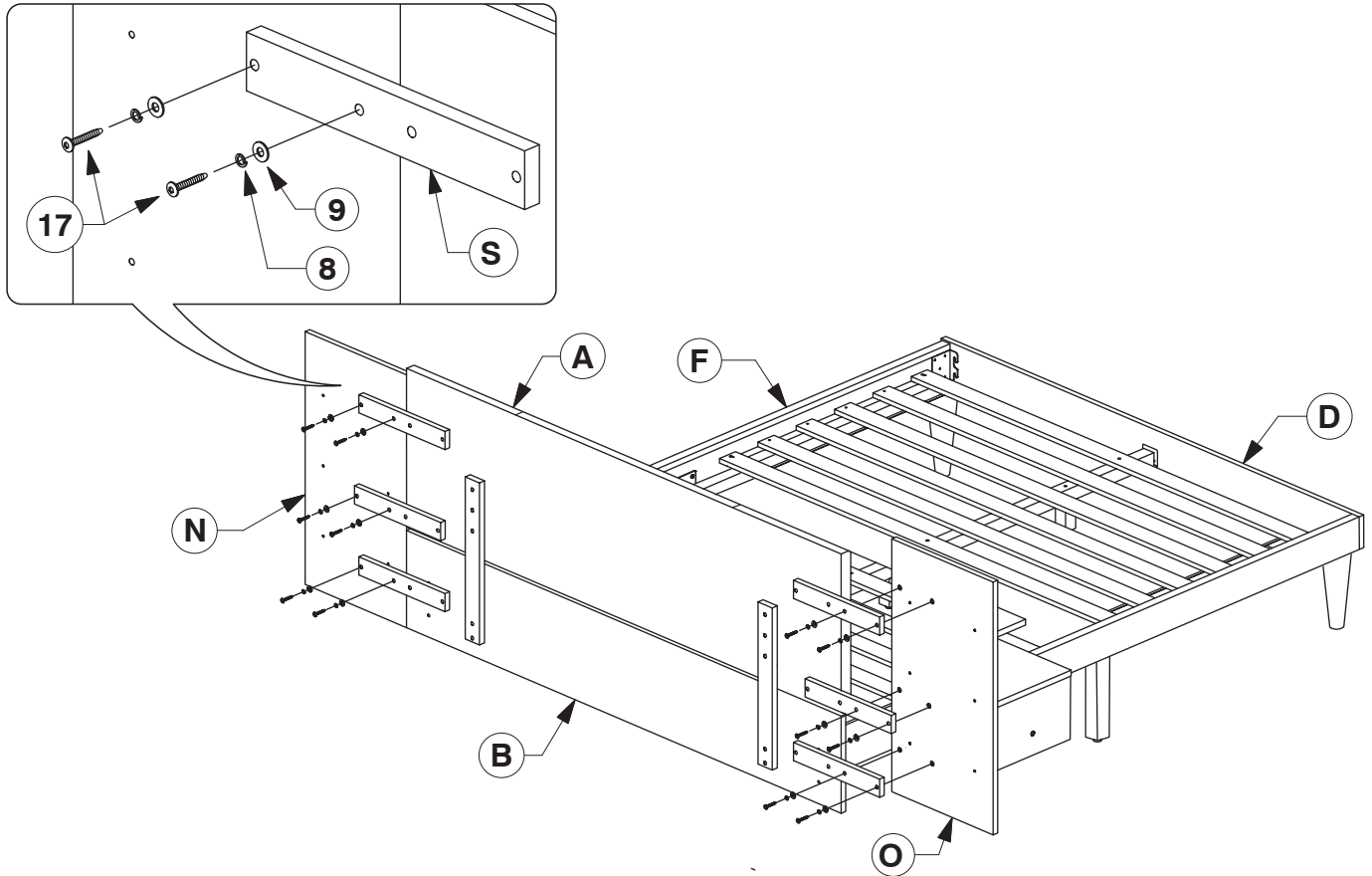

**23** Finally fit the assembled Drawers.

