



Read this instruction carefully. See hardware and furniture part list for guidance. Be sure all parts are complete, before you assemble. Place all wooden furniture parts on a clean and flat soft surface to prevent from being scratched. Follow the figure to start assembling.

CAUTIONS : 1. Do not FULLY - TIGHTEN the nut or nut bolt until all nut or bolt is ready assembled.
 2. Do not OVER - TIGHTEN the nut or bolt to avoid causing damages to the thread.
 3. Keep all hardware parts out of reach of children.

PART LIST		
ITEM	DESCRIPTION	QTY
A	CHAIR	1 PC
B	FRONT LEG	2 PCS
C	BACK LEG (L/R)	2 PCS

HARDWARE LIST		
ITEM	DESCRIPTION	QTY
1	JCBB BOLT M8 x 50mm 	8 PCS
2	M8 FLAT WASHER 	8 PCS
3	M8 SPRING WASHER 	8 PCS
4	M5 ALLEN KEY (BALL SHAPE) 	1 PC

NOTE : THE LIST AND QUANTITY SHOWN ARE FOR 1 UNIT ASSEMBLY.

Tool needed : Screwdriver (not provided).

STEP 1

Take out the legs underneath the seat.

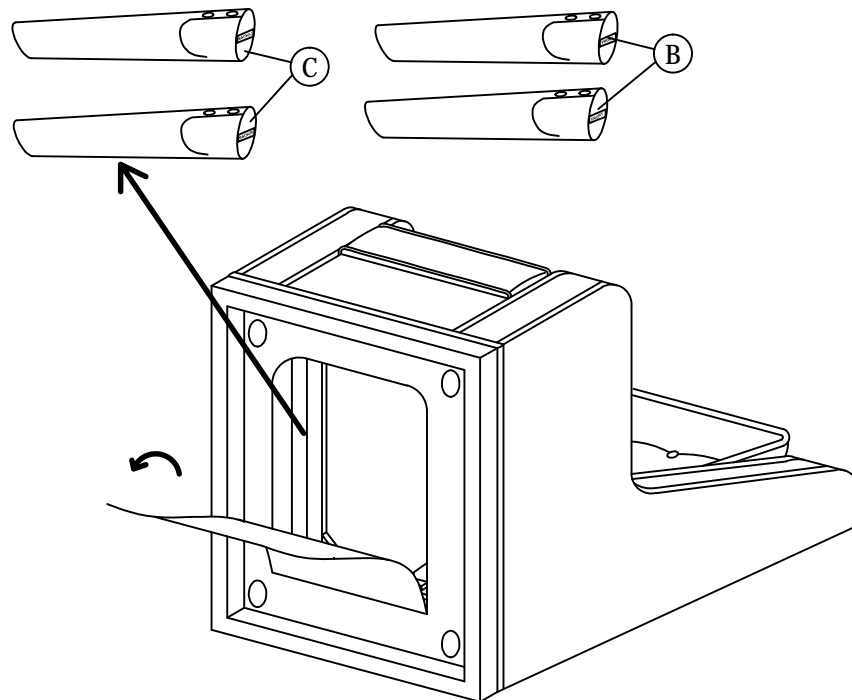

STEP 2

FRONT LEG

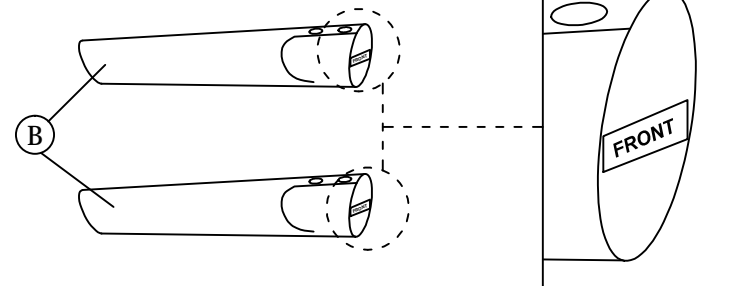

BACK LEG

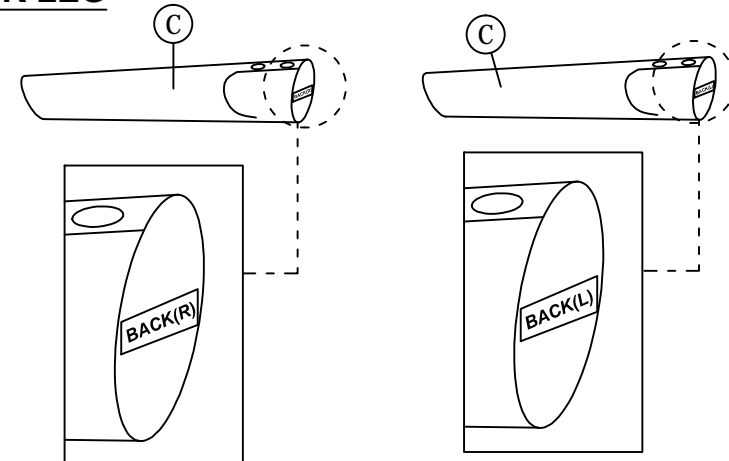

ASSEMBLY INSTRUCTIONS

STEP 3

STEP 3.1

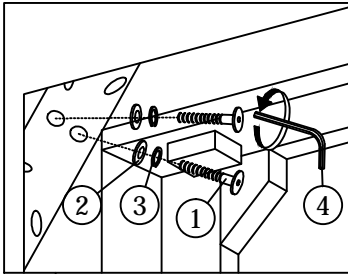

FRONT

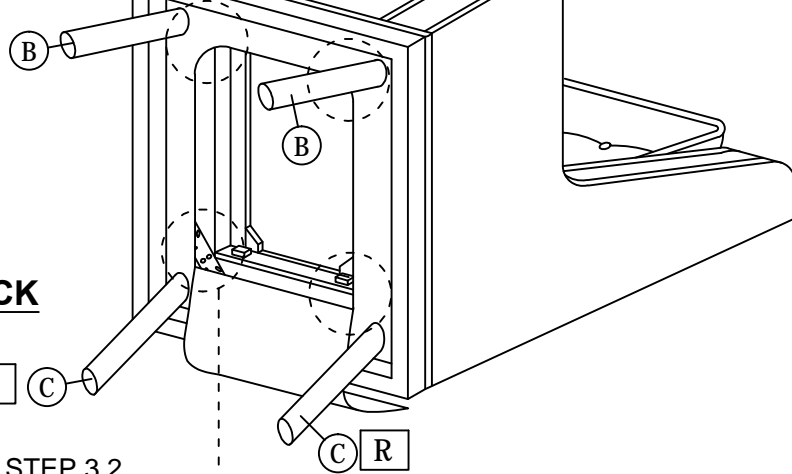

BACK

STEP 3.2

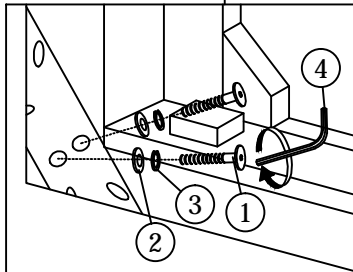

STEP 4

