

# ASSEMBLY INSTRUCTIONS

ITEM NO: UPH COUNTER CHAIR

Read instruction carefully prior to assembly.







Thank you for purchasing this quality product. Check carefully for small parts which may come loose during shipment. Remove all components from pack and place top down on soft surface such as carpet or cloth to prevent scratching the finish. Identify and count all parts as specified below.

It is recommended to use one person during the assembly process.



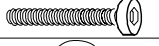

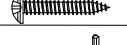
## TOOLS REQUIRED (NOT INCLUDED)

Description	Sketch
Screw Driver	

## HARDWARE LIST:

No.	Description	Sketch	Size	Qty
H1	Allen Bolt		Ø1/4 x 75mm	4 PCS
H2	Allen Bolt		Ø1/4 x 38mm	2 PCS
H3	Allen Bolt		Ø1/4 x 50mm	4 PCS
H4	Flat Washer		Ø5/16 x 18 mm	10 PCS
H5	Lock Washer		Ø5/16	10 PCS
H6	Pan Head Screw		Ø8 X 38 mm	6 PCS
H7	Allen Key		4 mm	1 PC

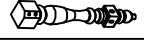
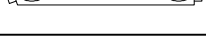
## PARTS IDENTIFICATION

No.	Description	Sketch	Quantity
A	Chair Back		1 PC
B	Seat Cushion		1 PC
C	Front Leg		2 PCS
D	Side Stretcher		2 PCS
E	Front Stretcher		1 PC

### Step 1

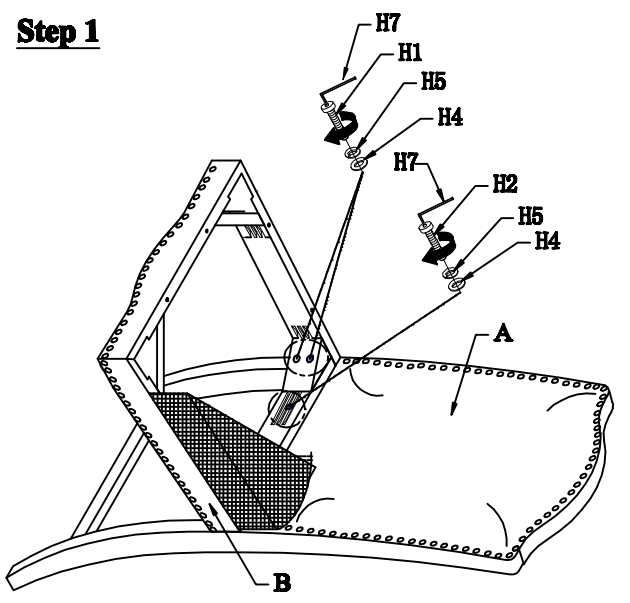

**Step 1:** Place the Chair Back (A) on the floor. Attach Seat Cushion (B) to the Chair Back (A) by using Flat Washer (4), Lock Washer (5), Allen Bolt (1) into the holes at the corner block of the Seat Cushion (B). Insert Flat Washer (4), Lock Washer (5), Allen Bolt (2) into the rear bar of the seat frame. Secure by Allen Key (7).

### Step 2

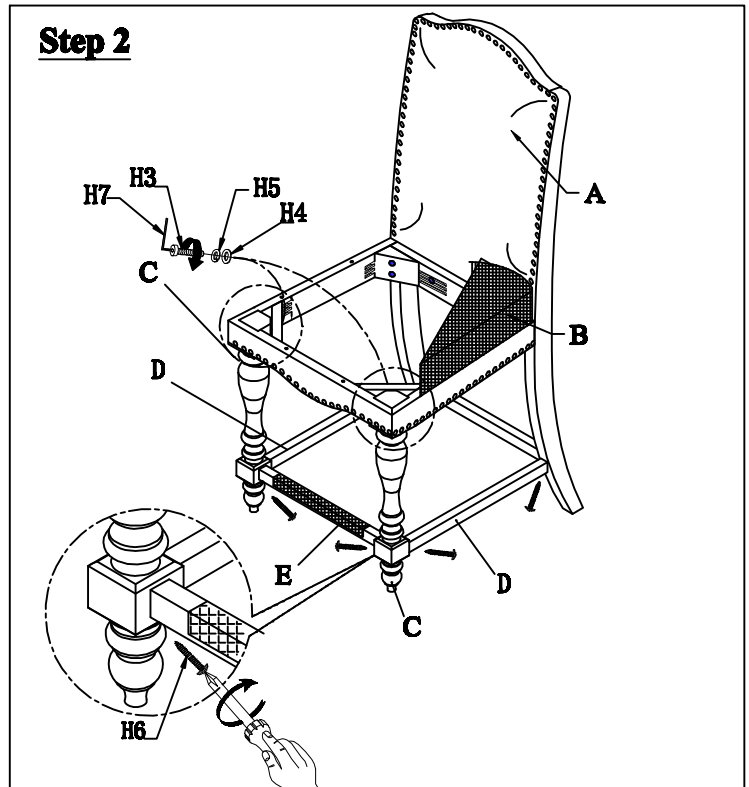

**Step 2:** Attach the front legs to seat Cushion using flat washer (4), lock washer (5) and Allen Bolt (3) by using Allen Key (7). Attach the front, left side, right side of Stretcher to Right, left of Front Leg and Chair back by securing the Pan Head Screw (6) with Phillips screw drivers (not included).