









HARDWARE LIST

A  WOODEN KNOB (4Pcs)	B  CHIPBOARD SCREW M4X32mm (8Pcs)	C  CHIPBOARD SCREW M4X16mm (24Pcs)	D  CAM LOCK & CAM BOLT (14Sets)	E  RUNNER 300mm (3Sets)	F  WOOD DOWEL M8X35mm (8Pcs)	G  WOOD DOWEL M6X30mm (24Pcs)	H  PANHEAD SCREW M4X25mm (4Pcs)
I  CAM LOCK COVER (14Pcs)							

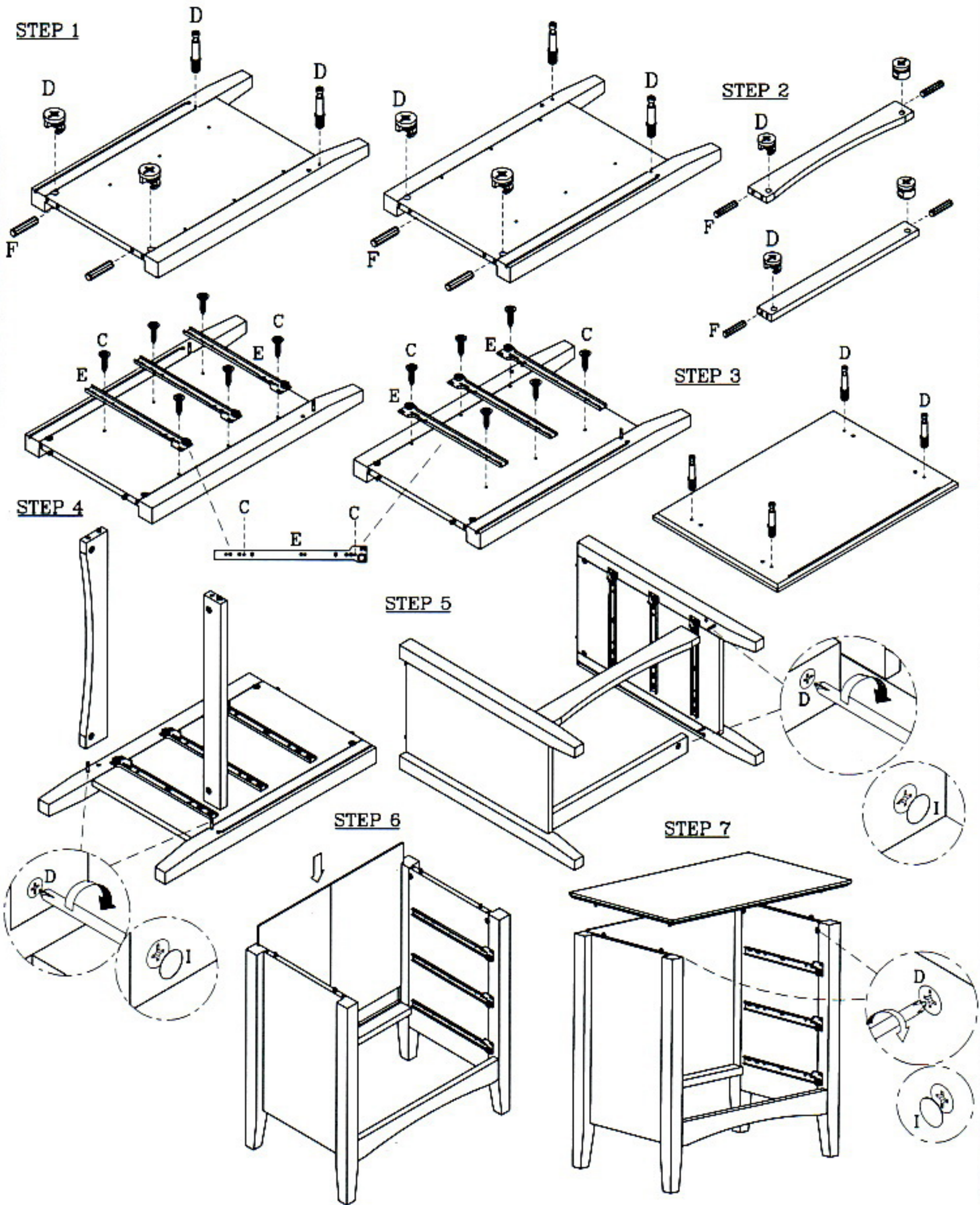

-THE UNIT SHOULD BE ASSEMBLED BY 2 OR MORE PEOPLE
 -EXTRA HARDWARE INCLUDED

STEP 1

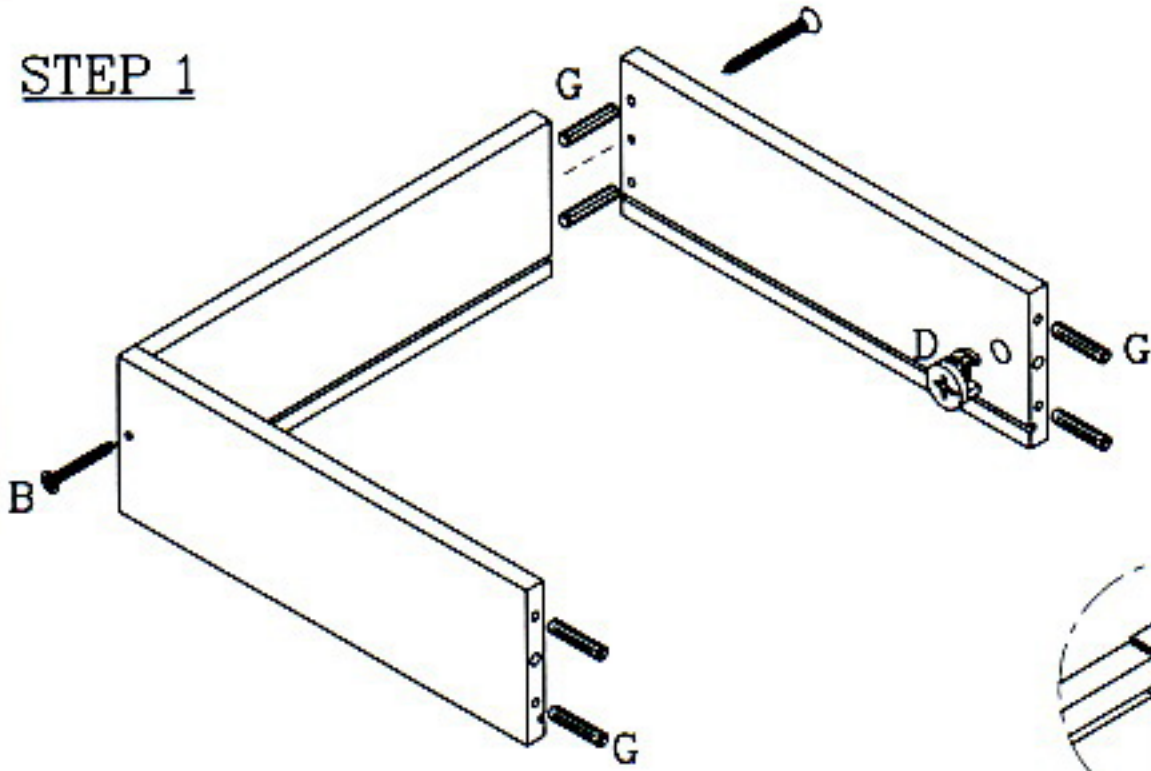

STEP 2

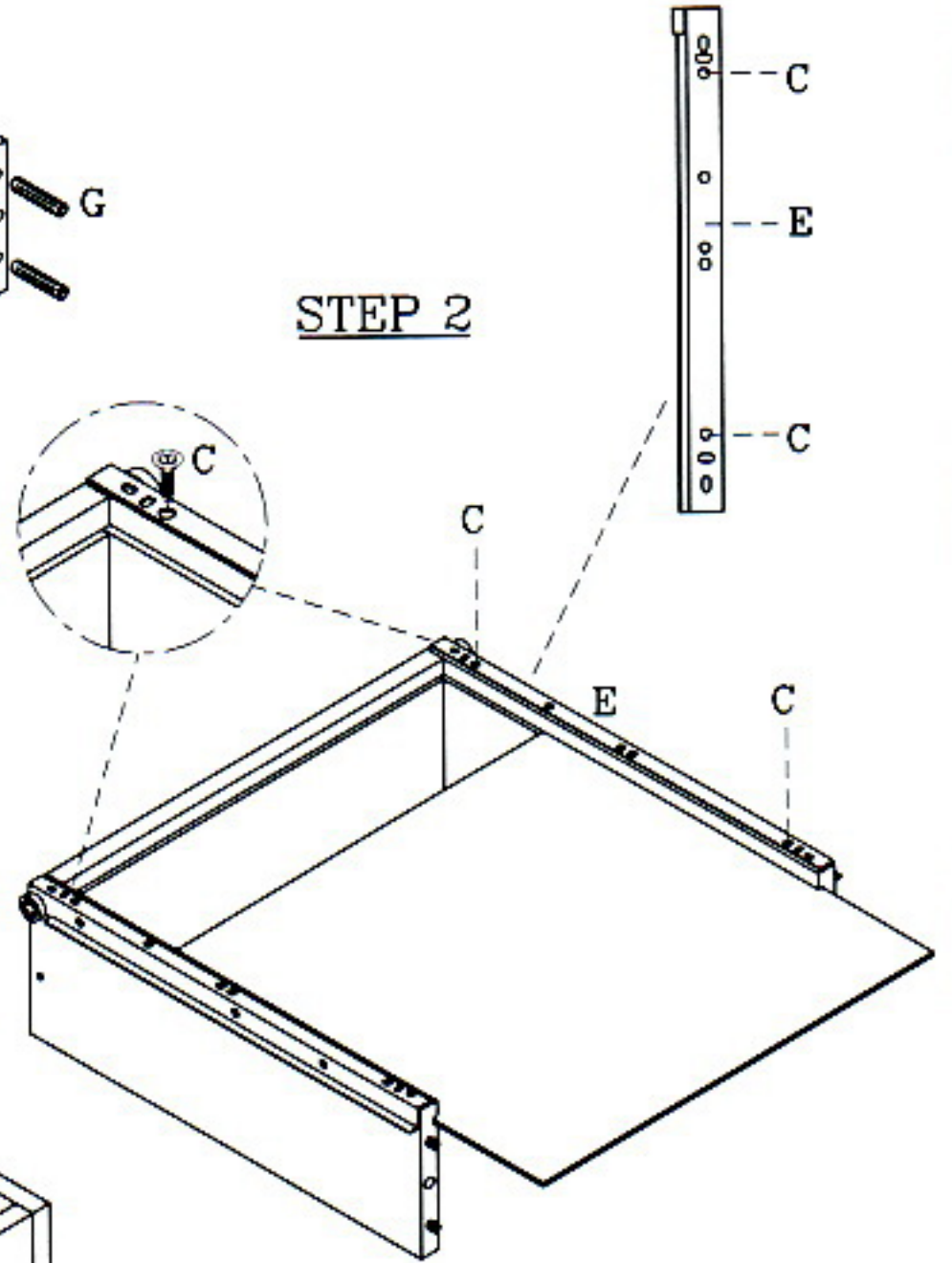

STEP 3

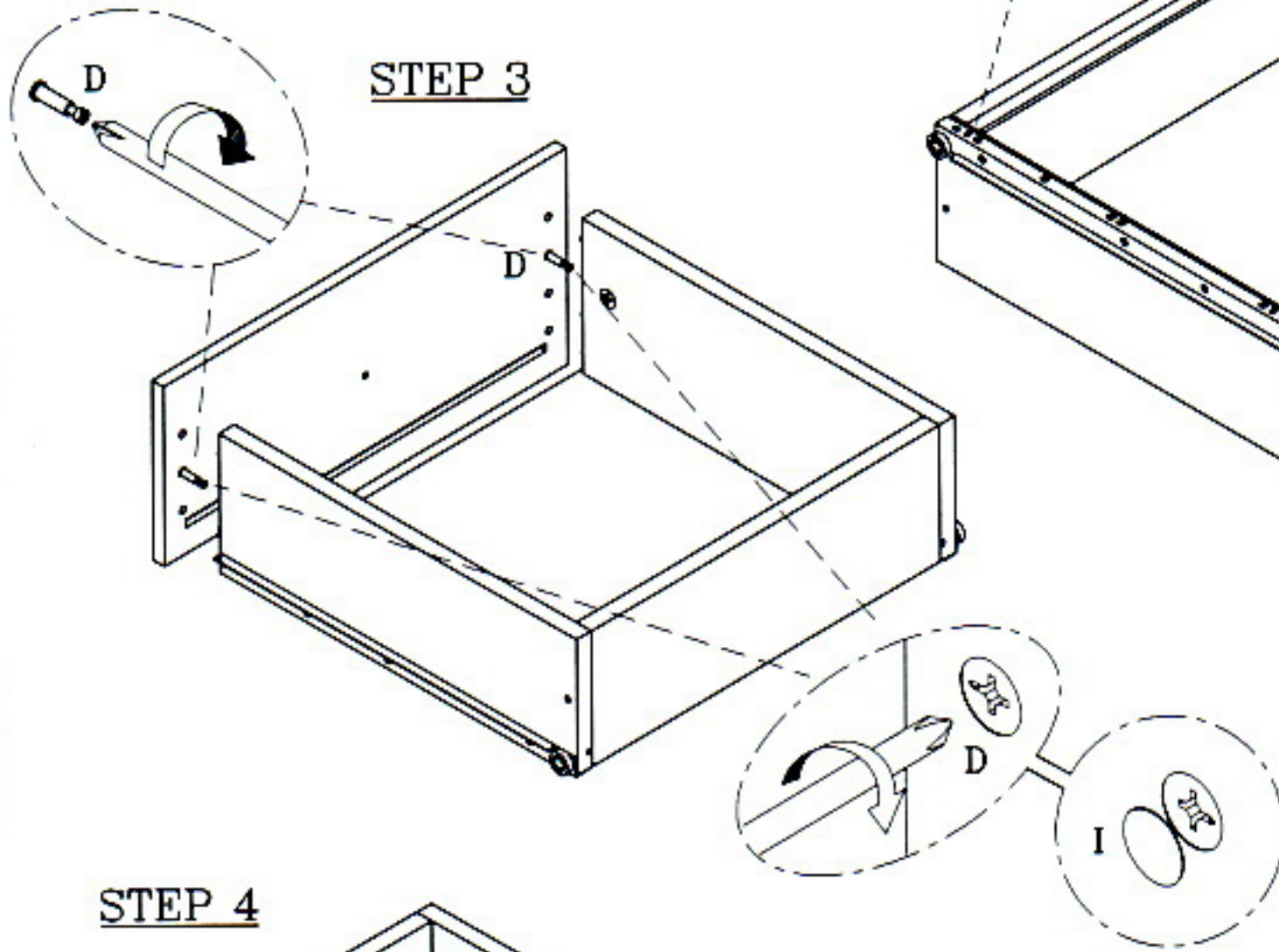

STEP 4

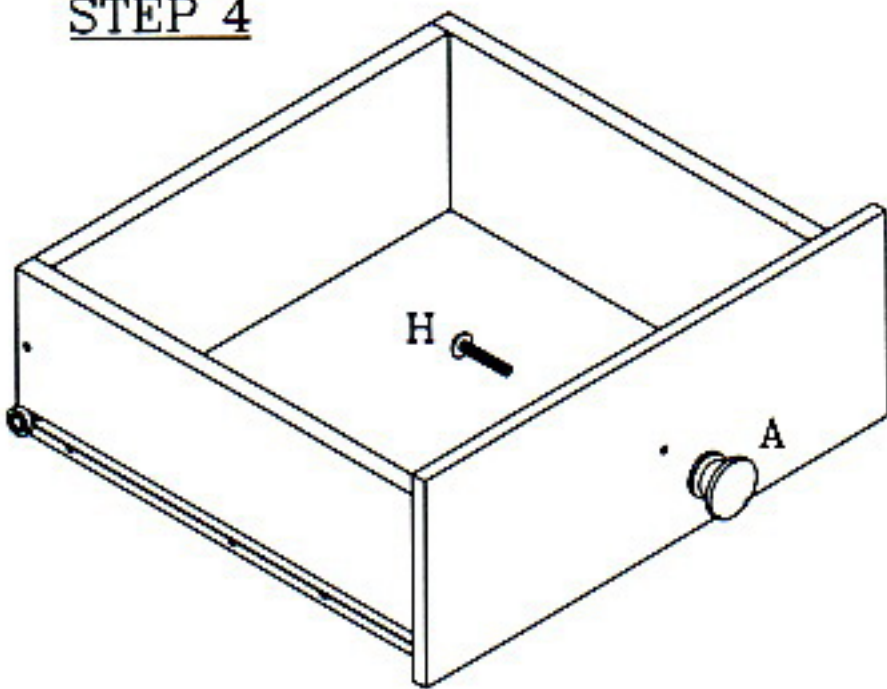

STEP 5

