

Assembly Manual

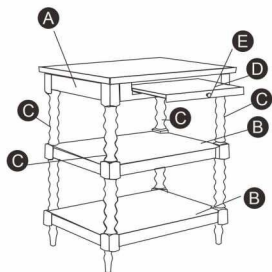

Step 1: Lay Part A with holes facing up on the flat surface.

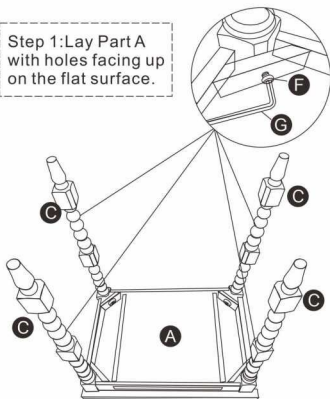

Step 2: Parts C screw to Part A using Parts F and Part G.

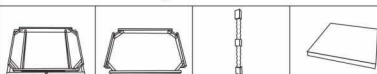

A	B	C	D
1PC	2PCS	4PCS	1PC



E
1PC



F
12PCS



G
1PC

Step 3: Parts B screw to Parts C using Parts F and Part G.

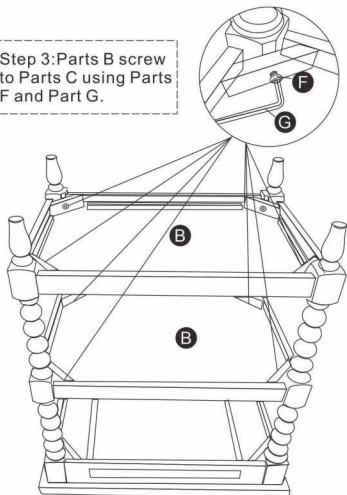

Step 4: Part E screws to Part D and then insert Part D into Part A.

