





Read this instruction carefully. See hardware and furniture part list for guidance. Be sure all parts are complete, before you assemble. Place all wooden furniture parts on a clean and flat soft surface to prevent from being scratched. Follow the figure to start assembling.

**CAUTION :** 1. Do not FULLY - TIGHTEN the nuts or nuts bolts until they are ready for assembly.  
 2. Do not OVER - TIGHTEN the nuts or bolts to avoid causing damages to the thread.  
 3. Keep all hardware parts out of reach of children.

**NOTE :** THE LIST AND QUANTITY SHOWN ARE FOR 1 UNIT ASSEMBLY.

Tools needed : Screwdriver (not provided).

PART LIST			
ITEM	DESCRIPTION	BOX	QTY
A	HEADBOARD	1	1 PC
B	FOOTBOARD	2	1 PC
C	SIDE RAIL	2	2 PCS
D	CENTER RAIL	2	1 PC
E	CENTER SUPPORT LEG	2	3 PCS
F	CENTER SUPPORT WOOD	2	2 PCS
G	BED SLAT	2	26 PCS
H	BED LEG	2	4 PCS

HARDWARE LIST (BOX : 2)		
ITEM	DESCRIPTION	QTY
1	WOOD SCREW M3.5 x 16mm 	8 PCS
2	BED SLAT SIDE FITTER 	26 PCS
3	BED SLAT CENTER FITTER 	13 PCS
4	M5 ALLEN KEY (BALL SHAPE) 	1 PC

## STEP 1

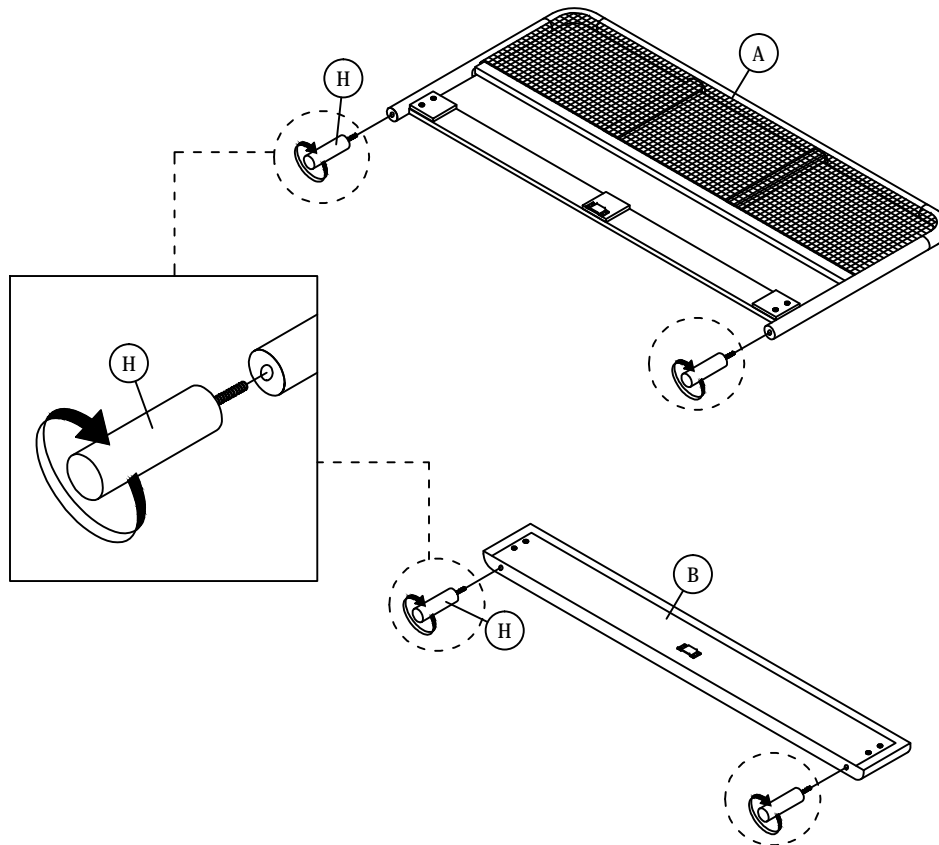

## STEP 2

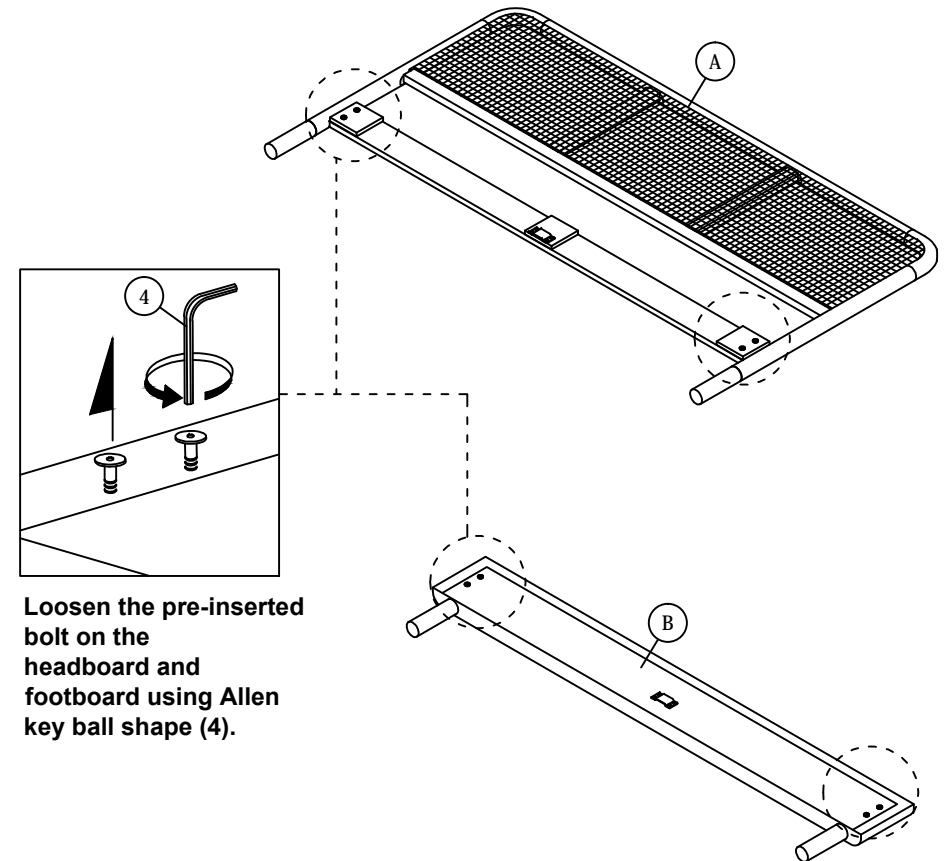

# ASSEMBLY INSTRUCTIONS

## STEP 3

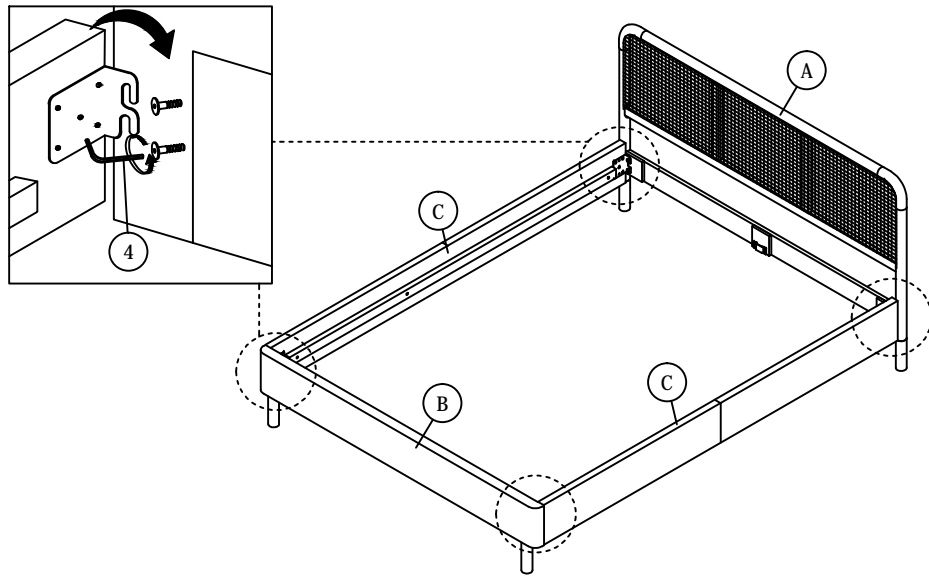

## STEP 4

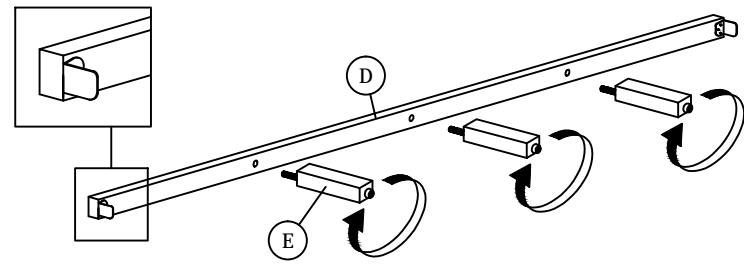

## STEP 5

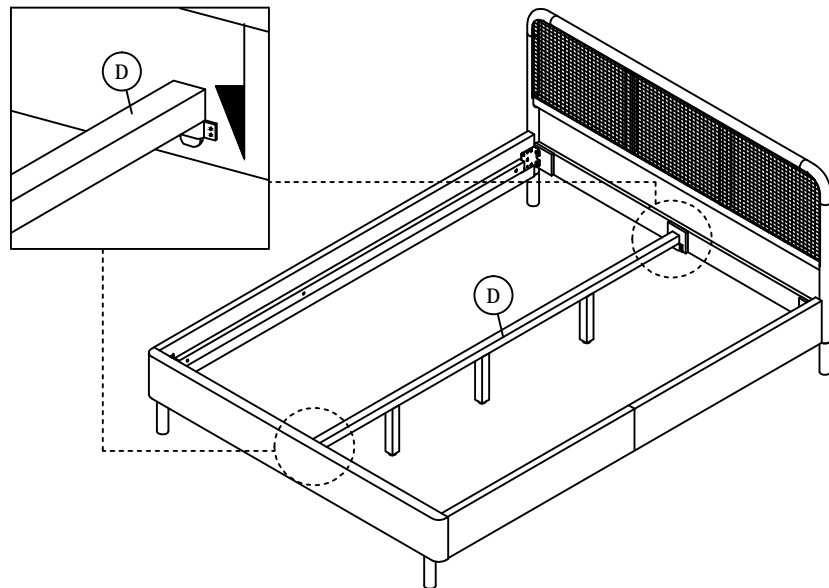

## STEP 6

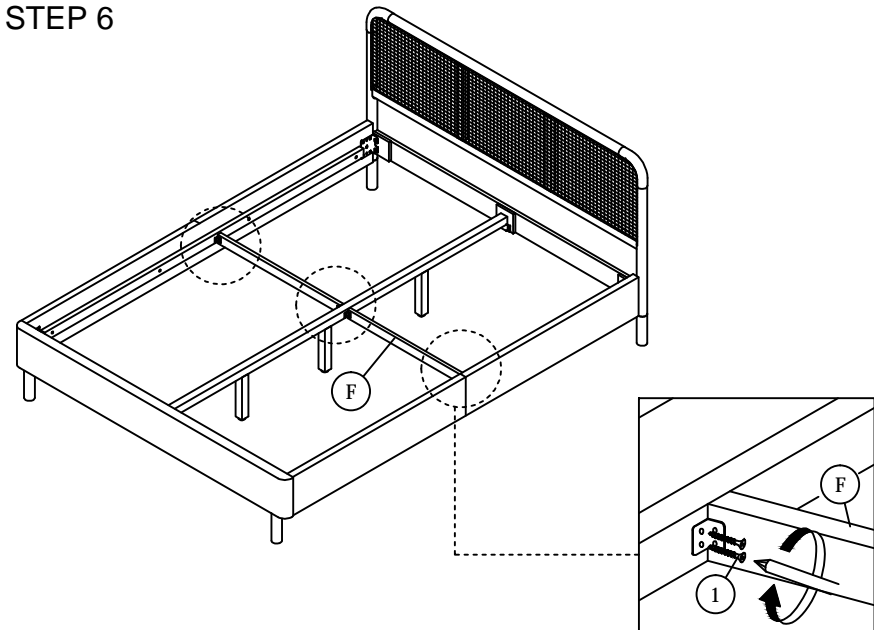

# ASSEMBLY INSTRUCTIONS

## STEP 7

### STEP 7.1

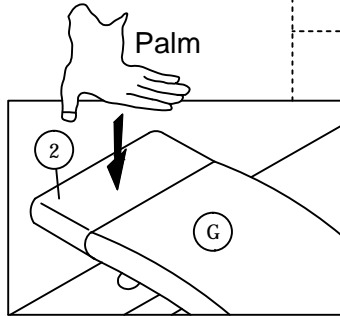
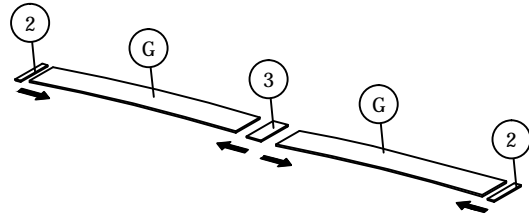
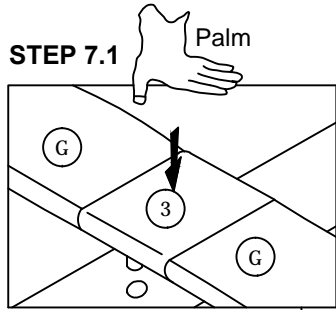

### STEP 7.2

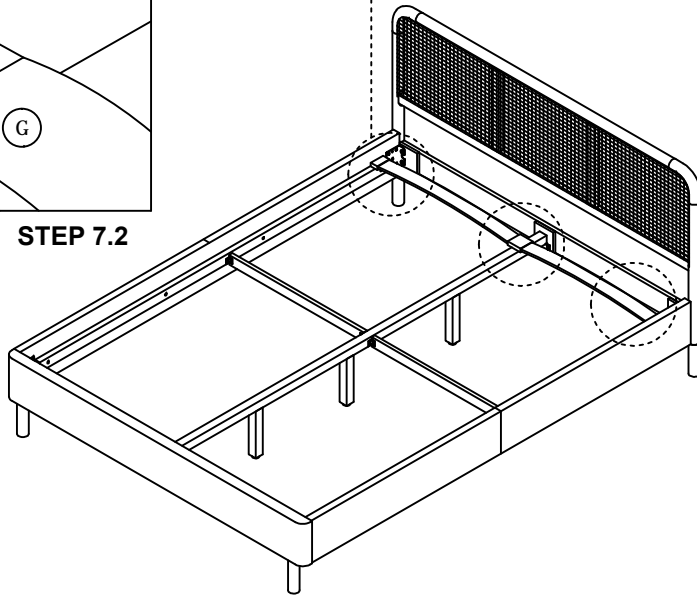

## STEP 8

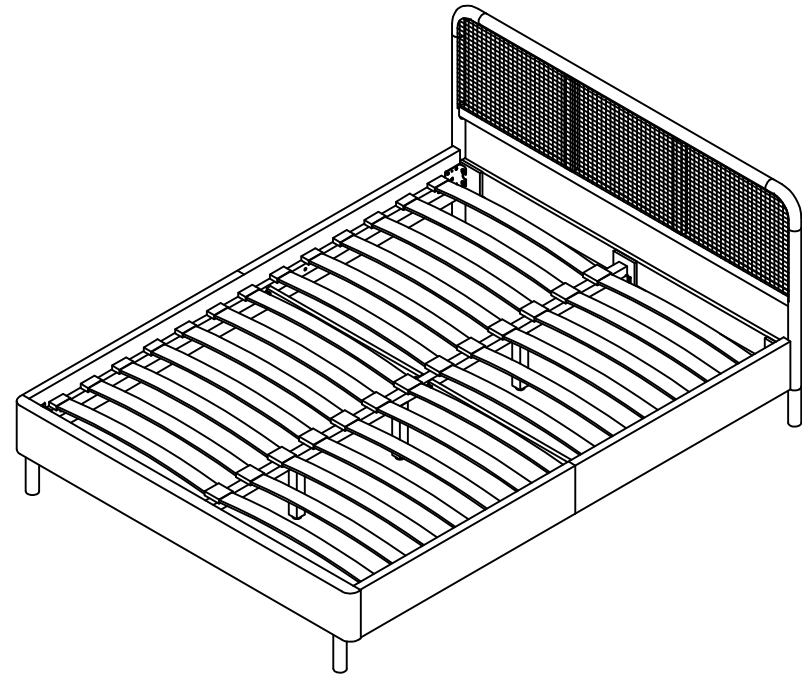

\* When moving the bed position, the center support legs must be adjusted or straightened to avoid any broken problems.