

0005-1 Full / Queen Headboard

Assembly Instructions

WI-0622

1 Parts List



A Headboard Panel x 1

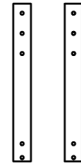

B Support Bar x 2

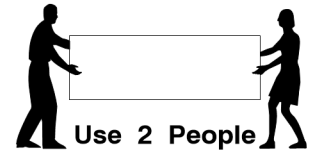

2 Hardware List



1 M6 x 35mm JCB x 10



2 Spring Washer x 10



3 Flat Washer x 10



4 Allen Key x 1

Note: Do not assemble using power tools. This can cause the bolts to be overtightened

3 Assemble the Support Bars (B) to the Headboard Panel.

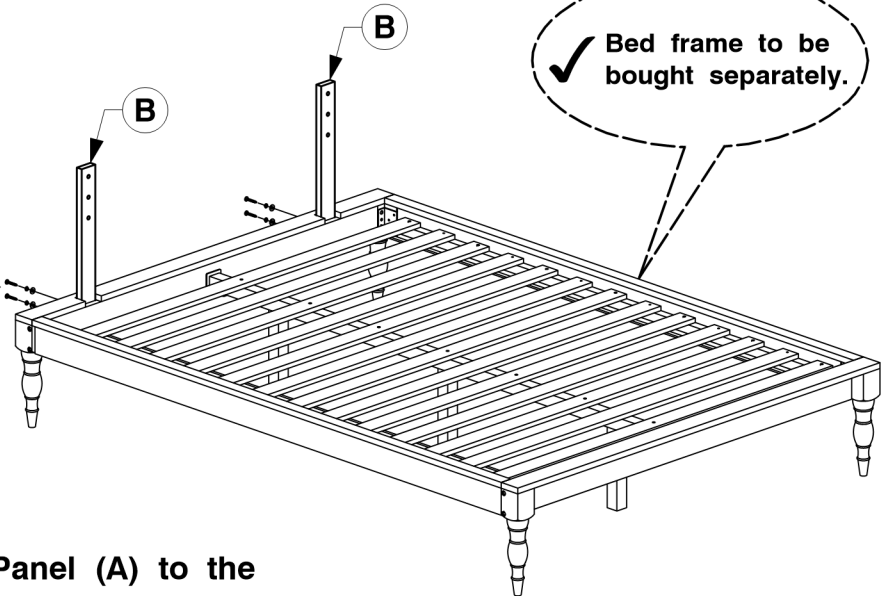
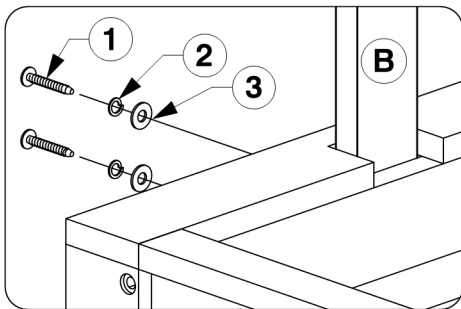

4 Assemble the Headboard Panel (A) to the Support Bars (B).

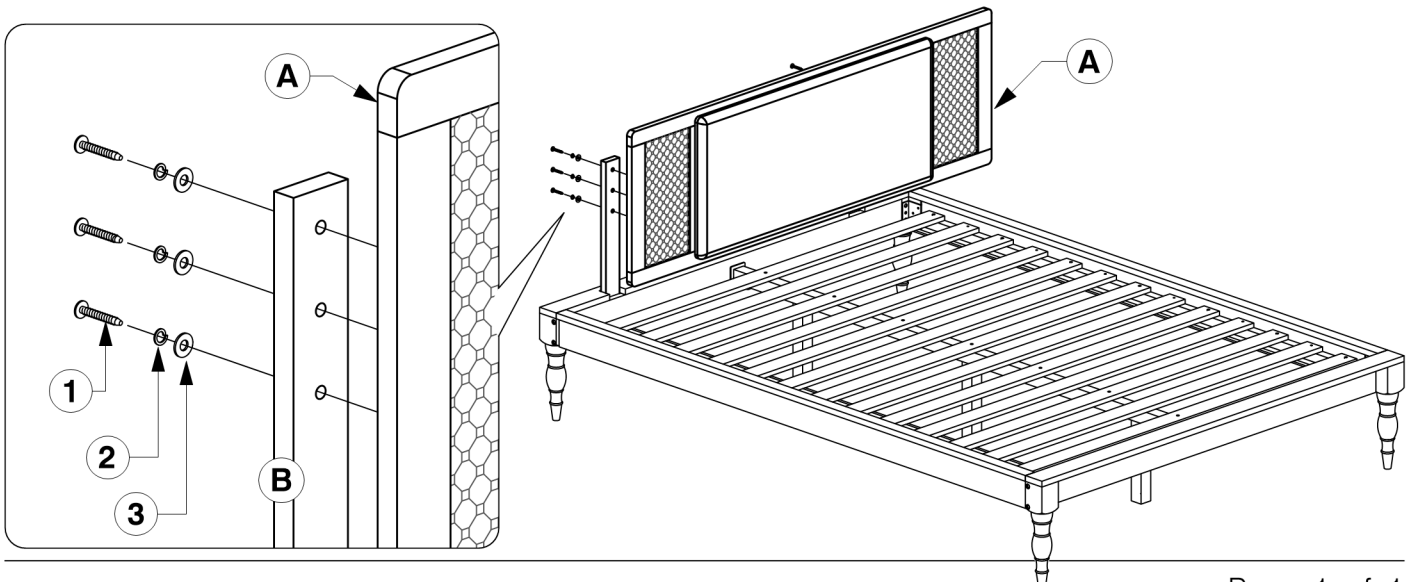

Queen Bed

Assembly Instructions

W11-0419

1 Assembled View

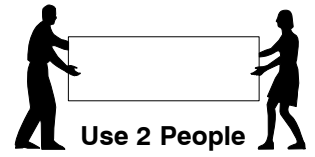
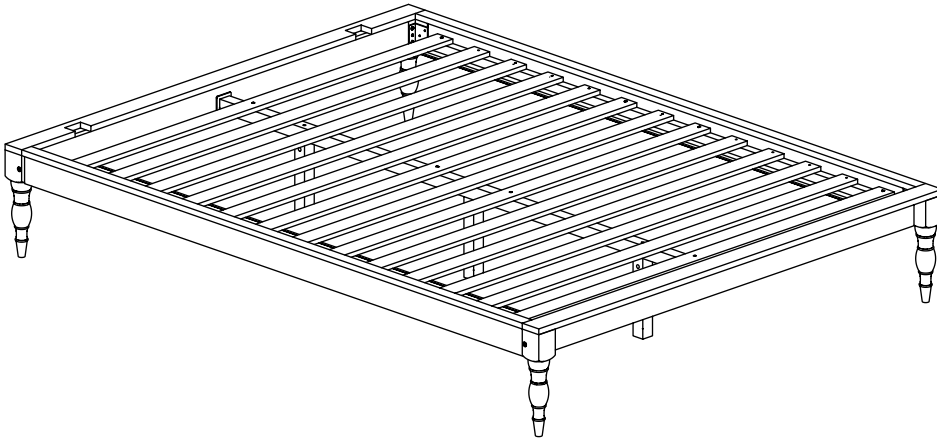

Note: Do not assemble using power tools. This can cause the bolts to be overtightened

2 Parts List

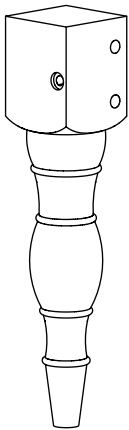

A
Post
(Left hand)
x 2

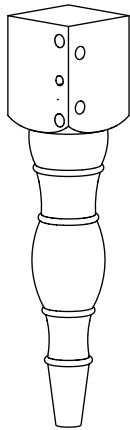

B
Post
(Right hand)
x 2

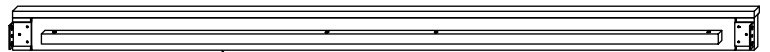

E Side Rail x 2

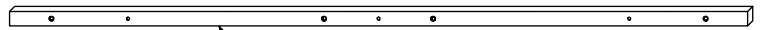

F Long Support x 1



G Support Leg x 3

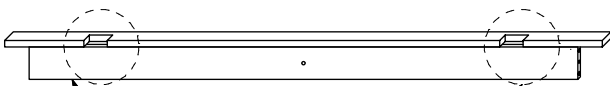

C Headboard Panel x 1

Extra Holes

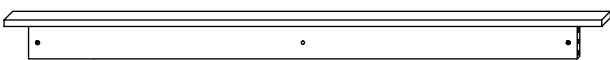

D Footboard Panel x 1

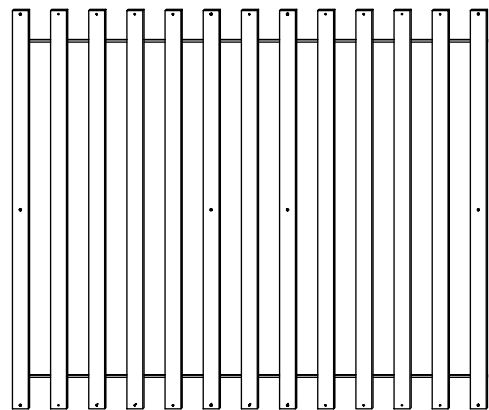

H Set of Bed Slats x 1

0005 Queen Bed

Assembly Instructions

WII-0419

3 Hardware List



1 M4 Allen Key
x 1

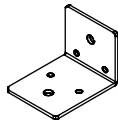

2 Center Rail
Bracket x 2

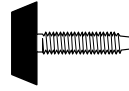

3 Adjustable
Foot x 3

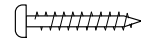

4 Wood Screw
(M4 x 32mm) x 18



5 Wood Dowel
(10 x 40mm) x 8



6 Barrel Nut
x 7



7 Spring Washer
x 12



8 Flat Washer
x 12



9 M6 x 15mm JCB
x 4



10 M6 x 20mm JCB
x 8



11 M6 x 40mm JCB
x 16



12 M6 x 100mm JCB
x 4



13 M6 x 90mm JCB
x 3

4 Assembled the Support Legs (G) to the Long Support (F).

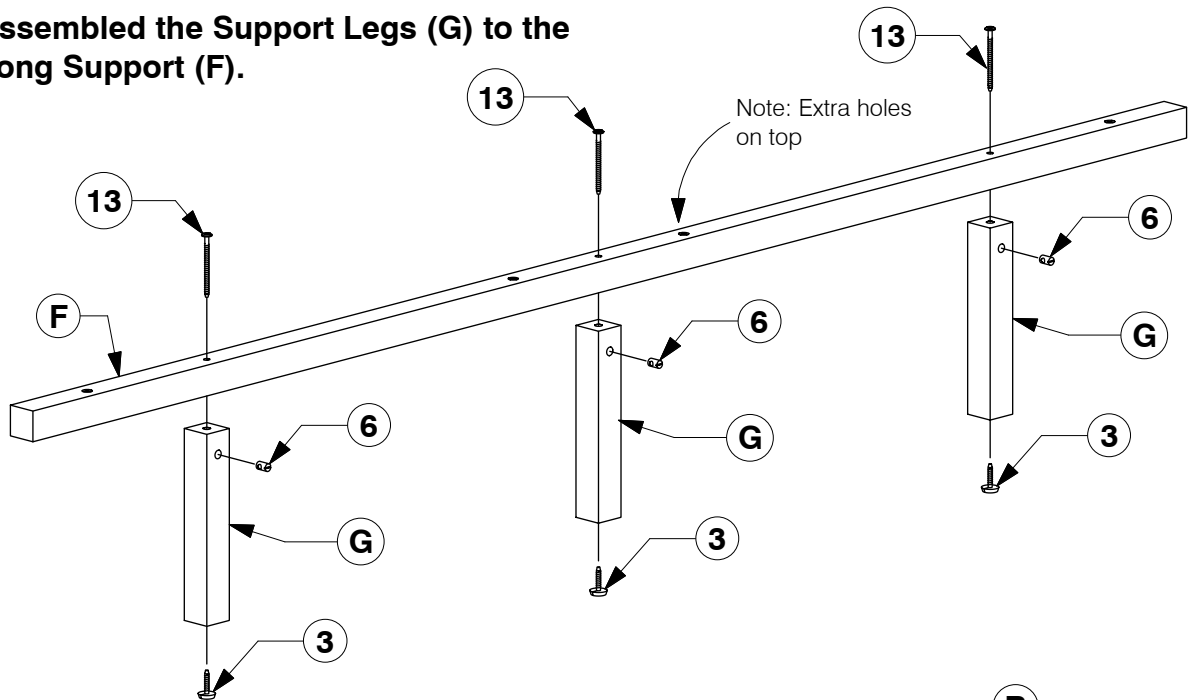

5 Assemble the Post (A & B) to the Headboard Panel (C). Fit the Center Rail Bracket to the Headboard Panel (C).

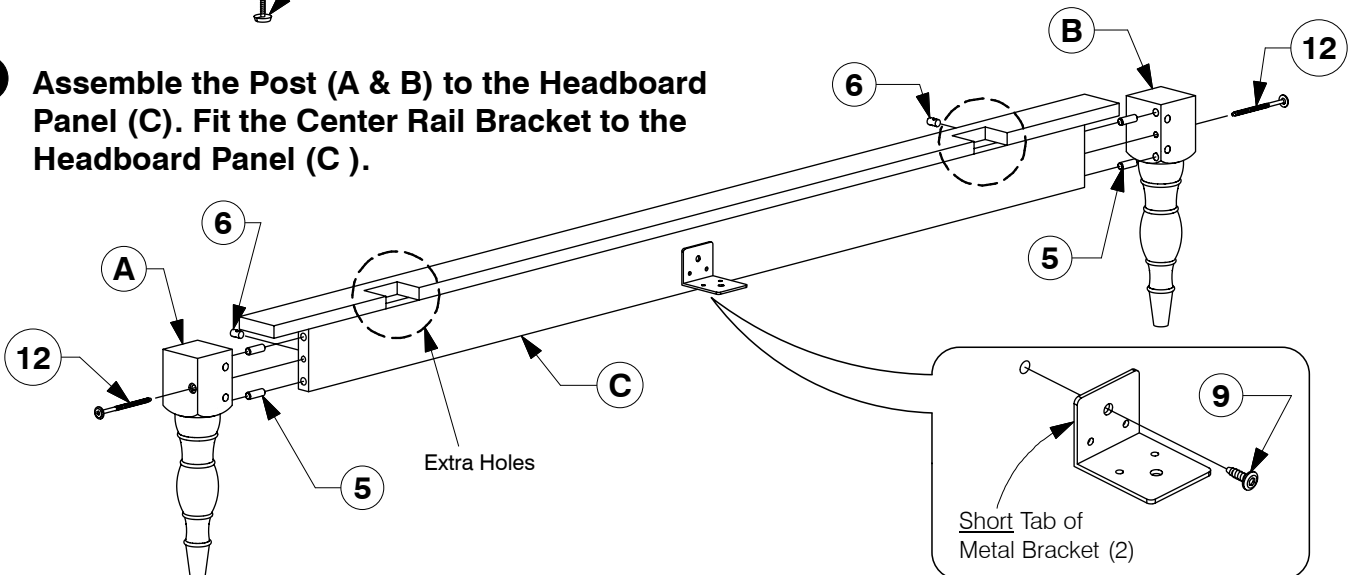

0005 Queen Bed

Assembly Instructions

WII-0419

- 6** Assemble the Post (A & B) to the Footboard Panel (D). Fit the Center Rail Bracket to the Footboard Panel (D).

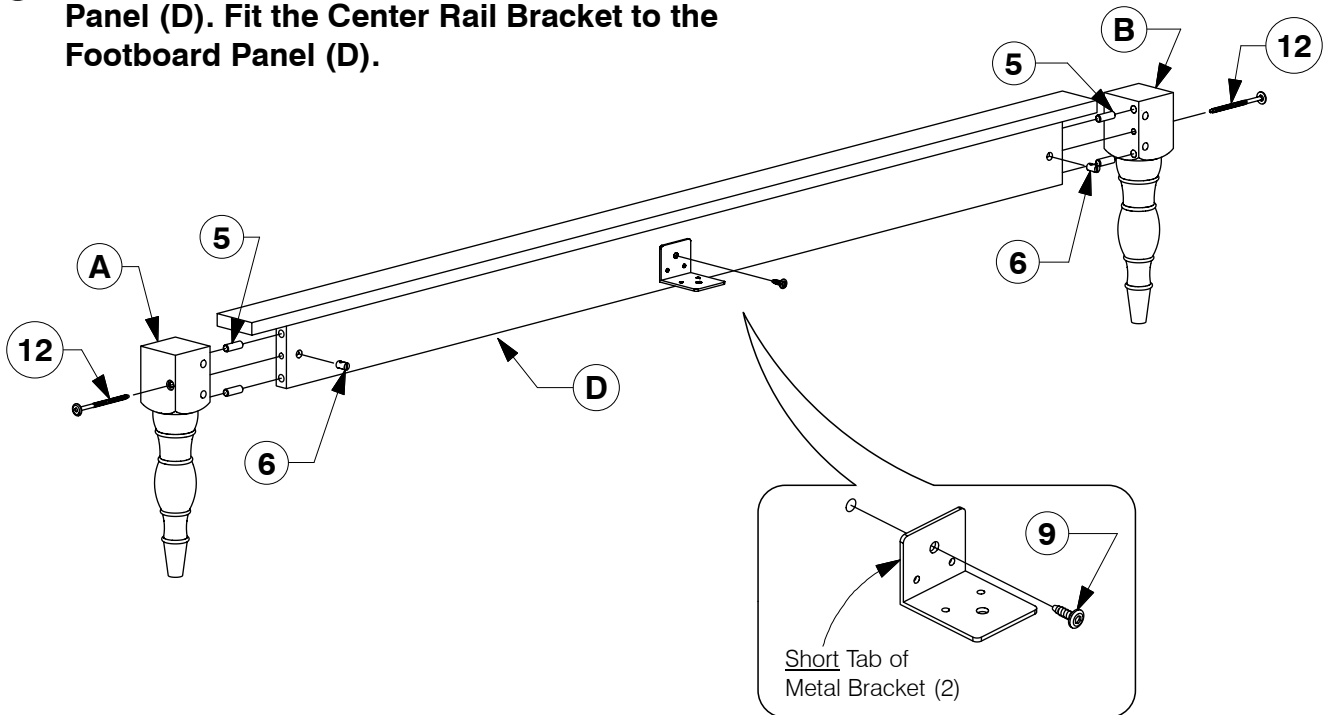

- 7** Assemble the Side Rail (E) to the Headboard & Footboard Panel (C & D).

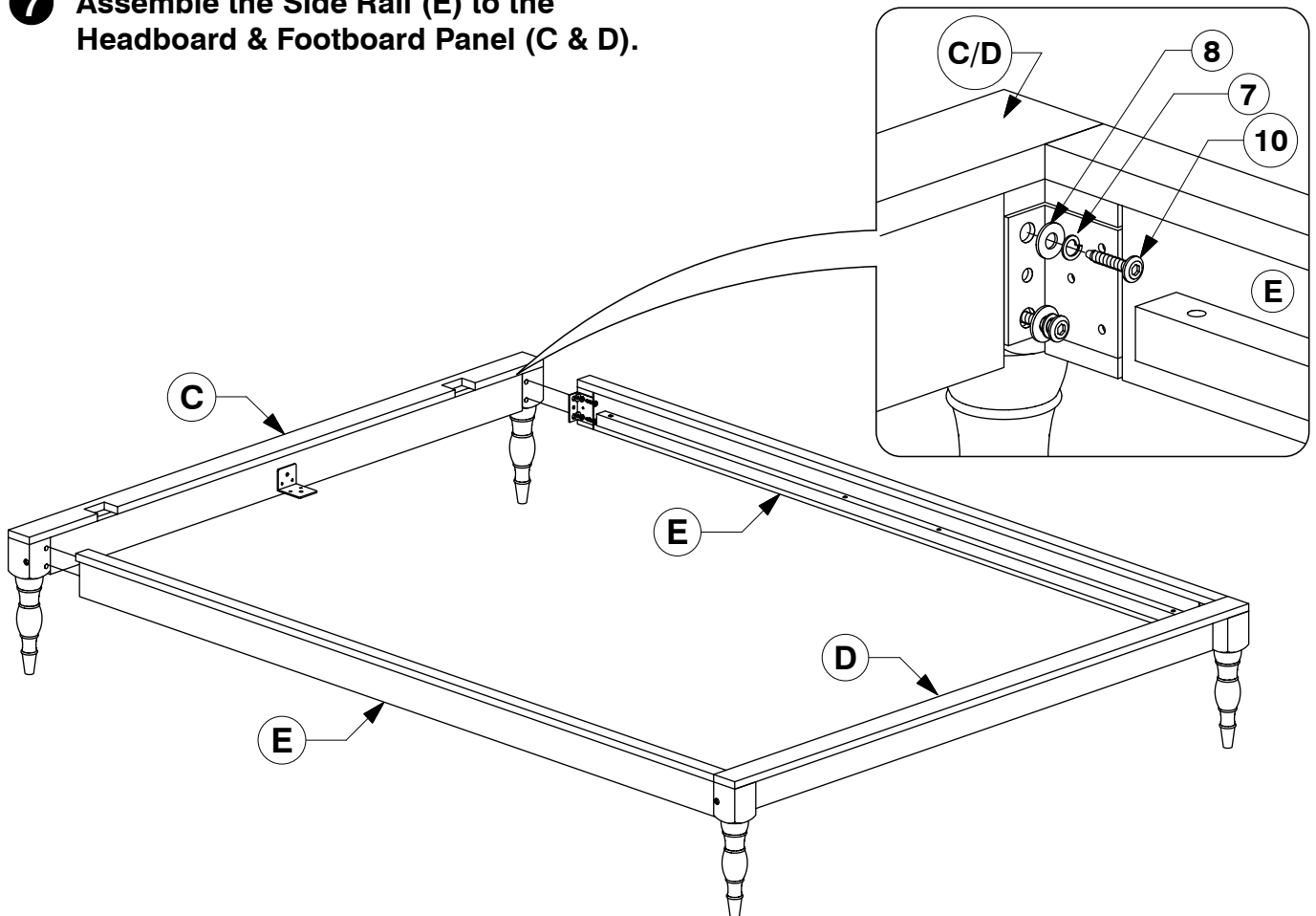

0005 Queen Bed

Assembly Instructions

WII-0419

- 8 Bolt the Long Support (F) to the Center Rail Brackets (2) on the Headboard & Footboard Panel (C & D).**

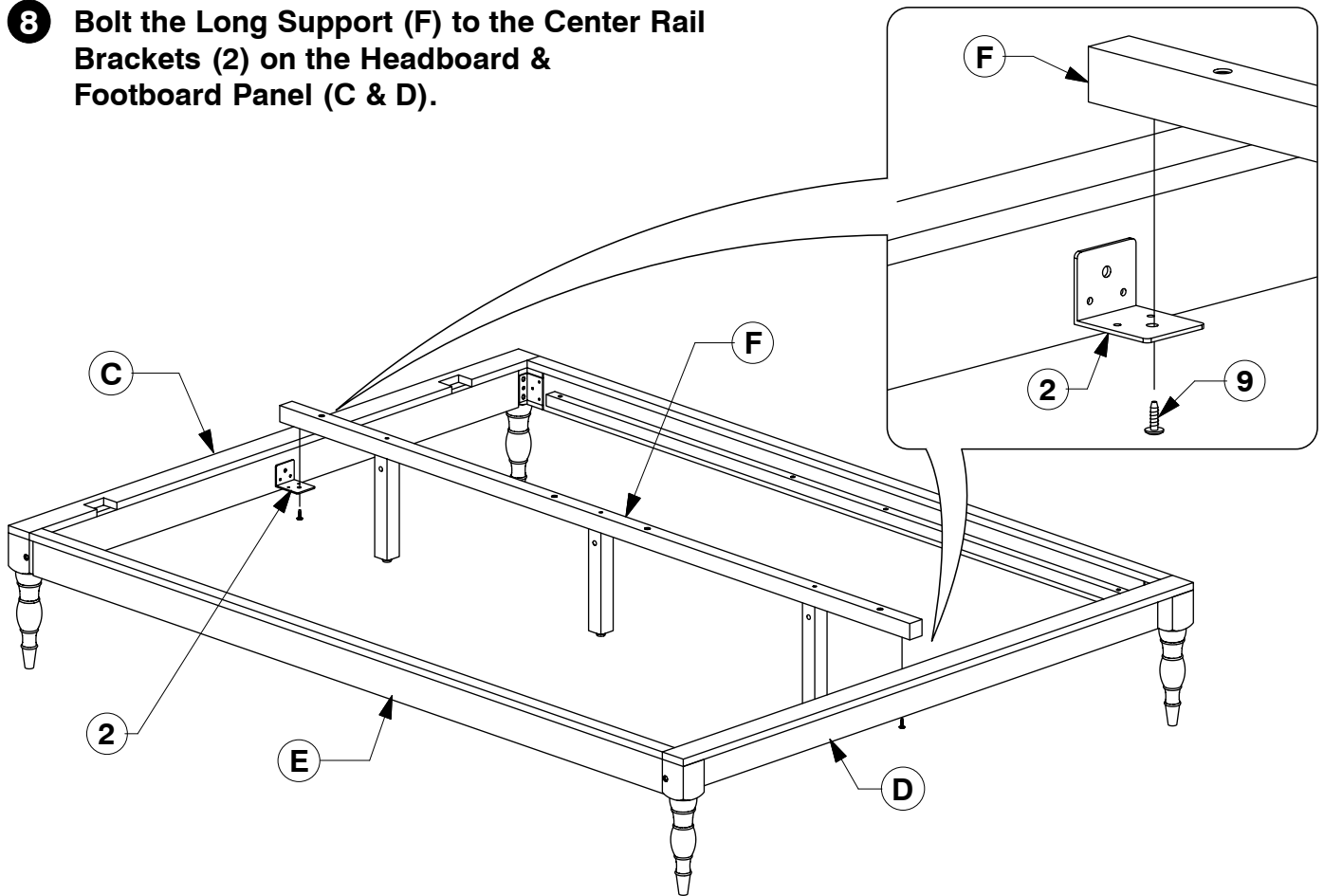

- 9 Bolt & screw the Bed Slats (H) to the Side Rail (E).**

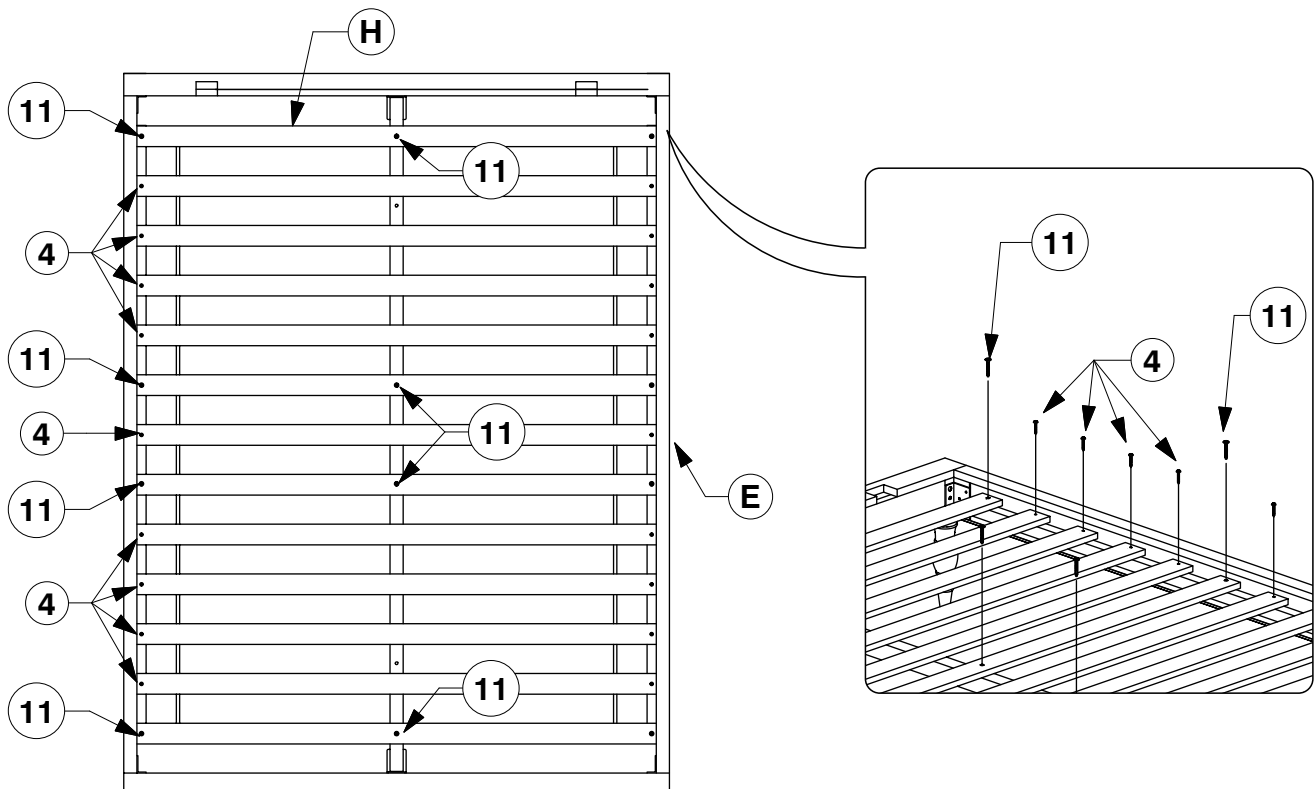

0005-1 King Headboard

Assembly Instructions

WI-0622

1 Parts List



A Headboard Panel x 1

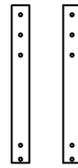

B Support Bar x 2

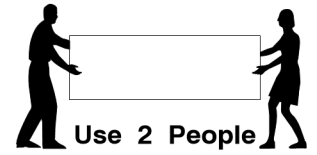

2 Hardware List

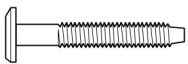

1 M6 x 35mm JCB x 10



2 Spring Washer x 10



3 Flat Washer x 10



4 Allen Key x 1

Note: Do not assemble using power tools. This can cause the bolts to be overtightened

3 Assemble the Support Bars (B) to the Headboard Panel.

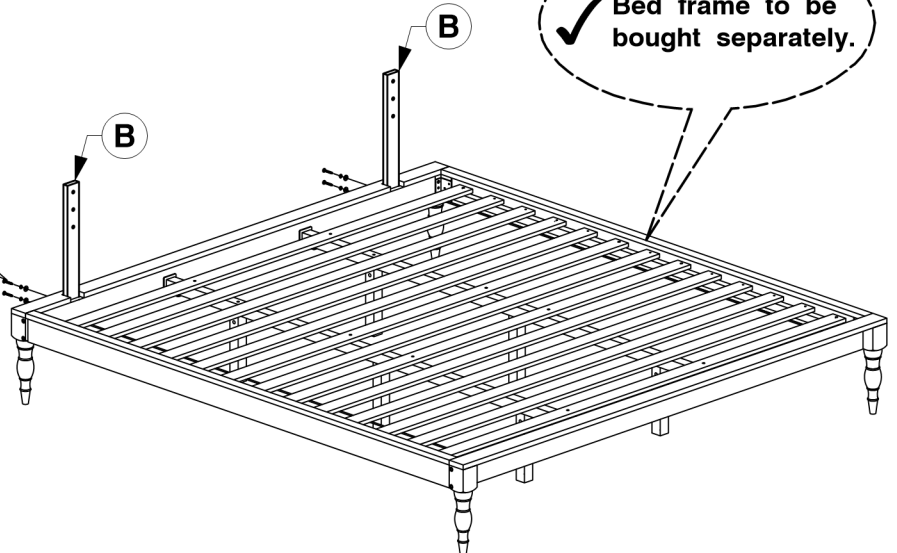
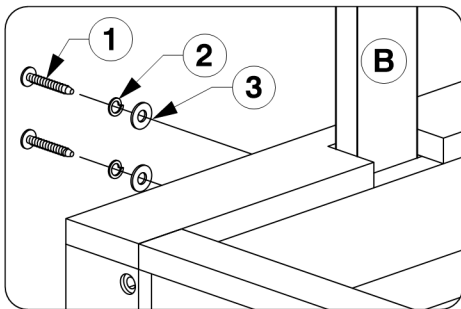

4 Assemble the Headboard Panel (A) to the Support Bars (B).

