

# 0005-1 Full / Queen Headboard

Assembly Instructions

WI-0622

## 1 Parts List



**A** Headboard Panel x 1

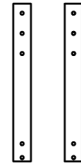

**B** Support Bar x 2

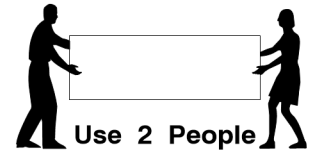

## 2 Hardware List



**1** M6 x 35mm JCB x 10



**2** Spring Washer x 10



**3** Flat Washer x 10



**4** Allen Key x 1

**Note:** Do not assemble using power tools. This can cause the bolts to be overtightened

## 3 Assemble the Support Bars (B) to the Headboard Panel.

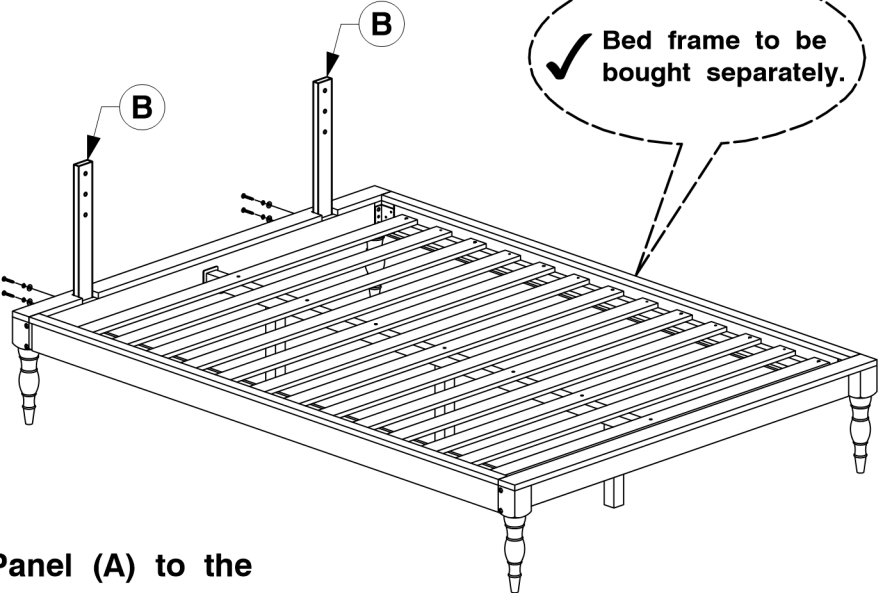
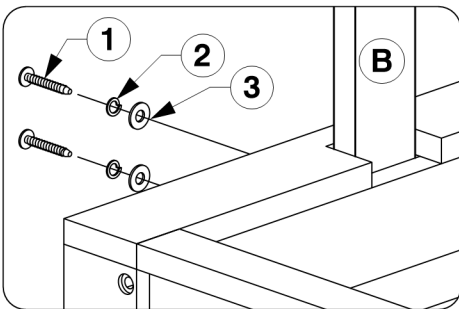

## 4 Assemble the Headboard Panel (A) to the Support Bars (B).

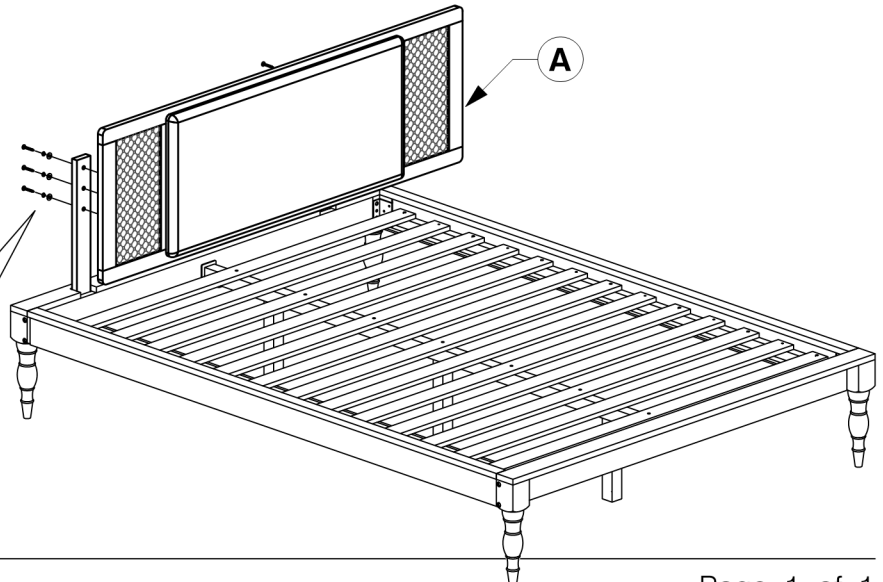
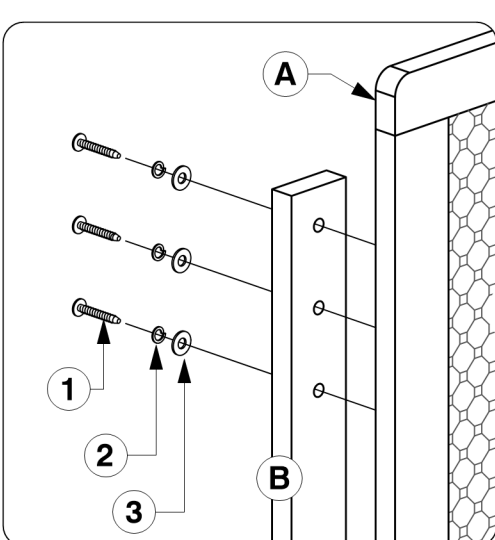

# 0004 Full Bed

## Assembly Instructions

W11-0819

### 1 Assembled View

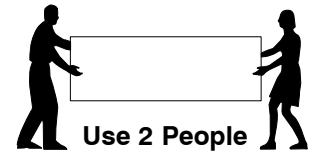
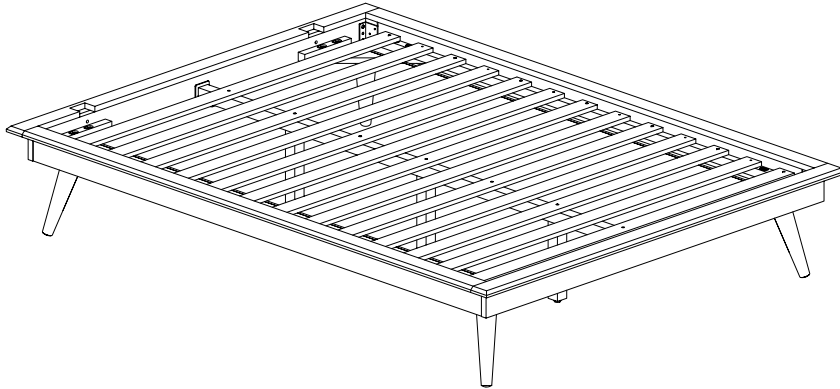

**Note:** Do not assemble using power tools. This can cause the bolts to be overtightened

### 2 Parts List

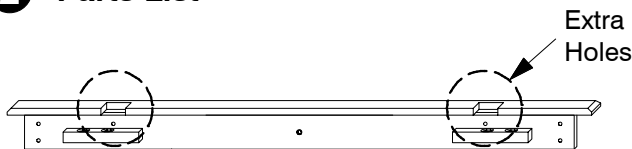

**A** Headboard Panel x 1

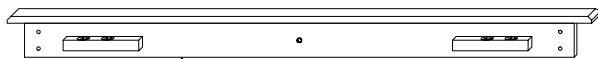

**B** Footboard Panel x 1

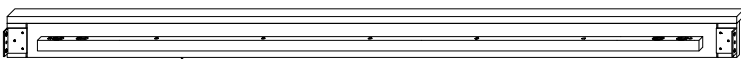

**C** Side Rail x 2

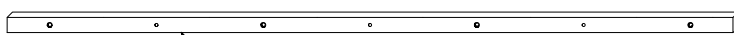

**D** Long Support x 1



**E** Post x 4



**F** Support Leg x 3

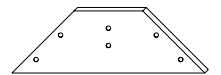

**G** Support Panel x 4

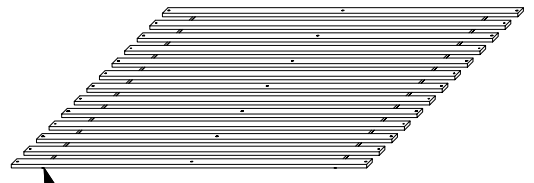

**H** Set of Bed Slats x 1

### 3 Hardware List



**1** M6 x 100mm JCB x 3



**2** M6 x 50mm JCB x 16

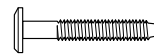

**3** M6 x 40mm JCB x 22



**4** M6 x 20mm JCB x 8



**5** M6 x 15mm JCB x 4



**6** M8 x 50mm JCB x 8



**7** Barrel Nut x 3



**8** Spring Washer x 28



**9** Flat Washer x 28

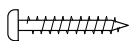

**10** Wood Screw (M4 x 32mm) x 12



**11** M4 Allen Key x 1



**12** M5 Allen Key x 1

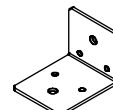

**13** Center Rail Bracket x 2

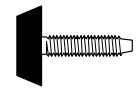

**14** Adjustable Foot x 3

# 0004 Full Bed

## Assembly Instructions

W11-0819

- 4** Fix the Adjustable foot to the bottom of the Support Leg (F).

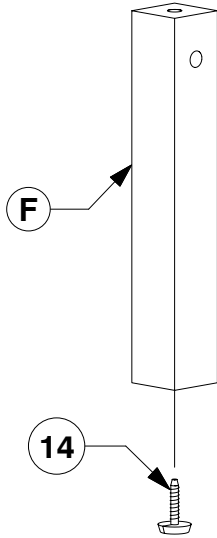

- 5** Fit the Post (E) to the Support Panel (G).

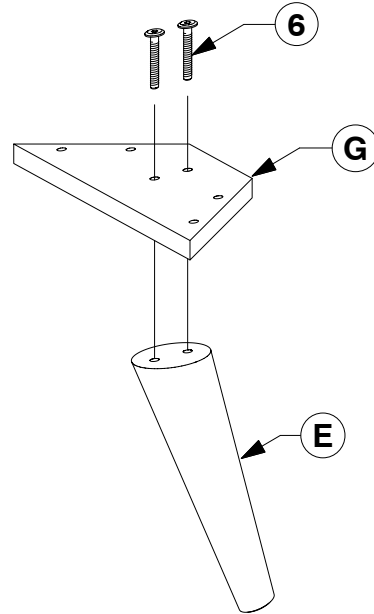

- 6** Fit the Center Rail Bracket to the Headboard Panel (A).

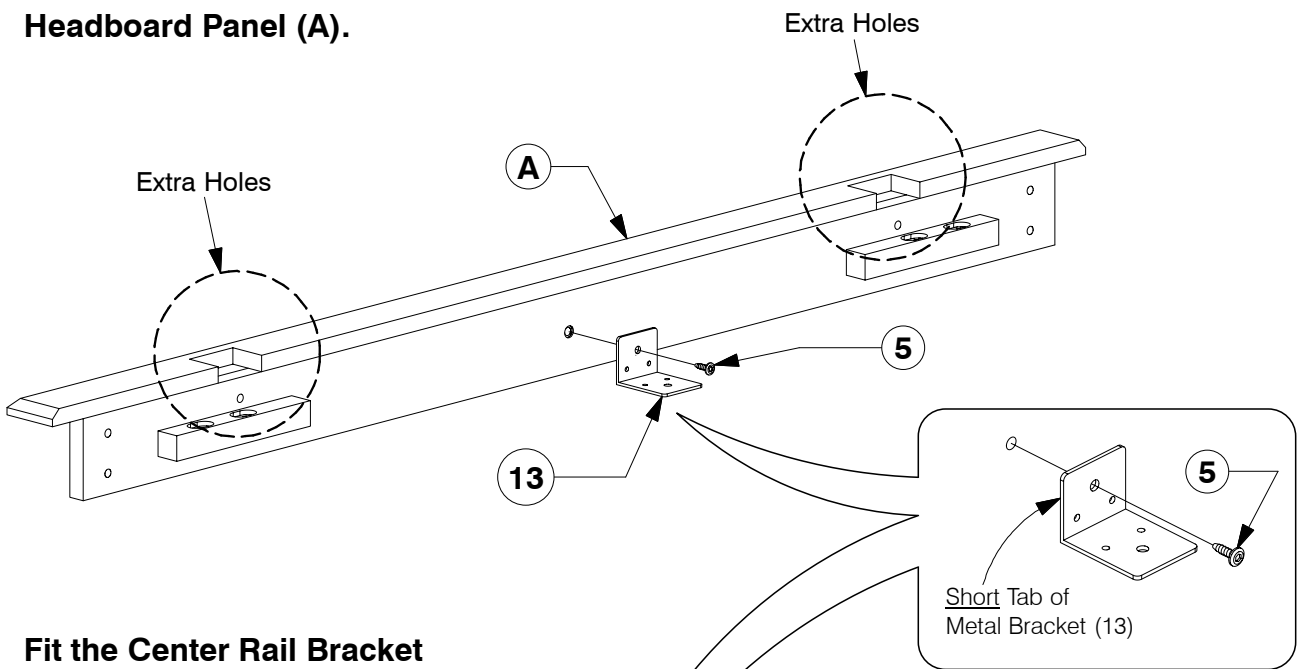

- 7** Fit the Center Rail Bracket to the Footboard Panel (B).

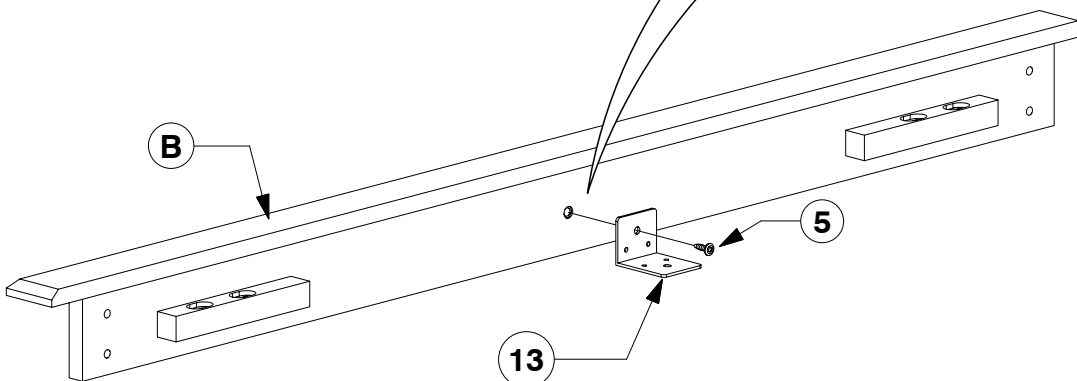

# 0004 Full Bed

## Assembly Instructions

WII-0819

- 8** Bolt the Post & Support Panel (E & G) to the Side Rail (C).

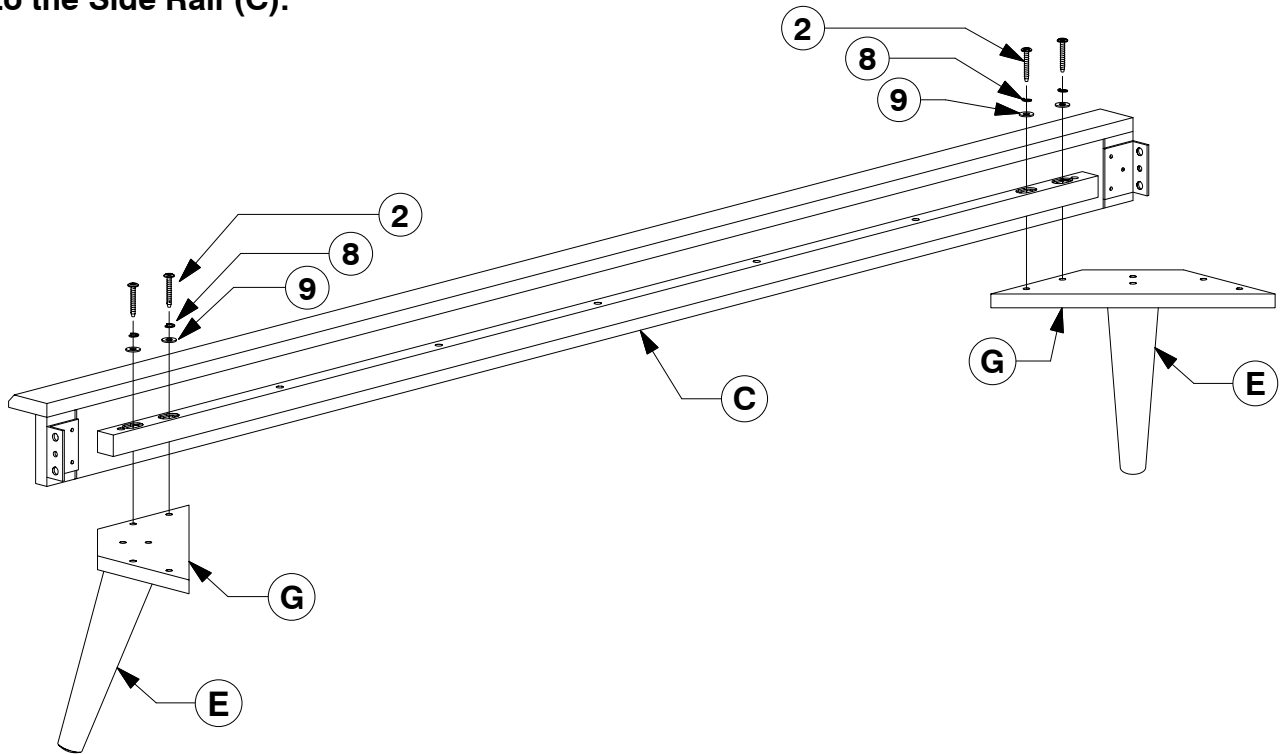

- 9** Assemble the Side Rail (C) to the Headboard & Footboard Panel (A & B).

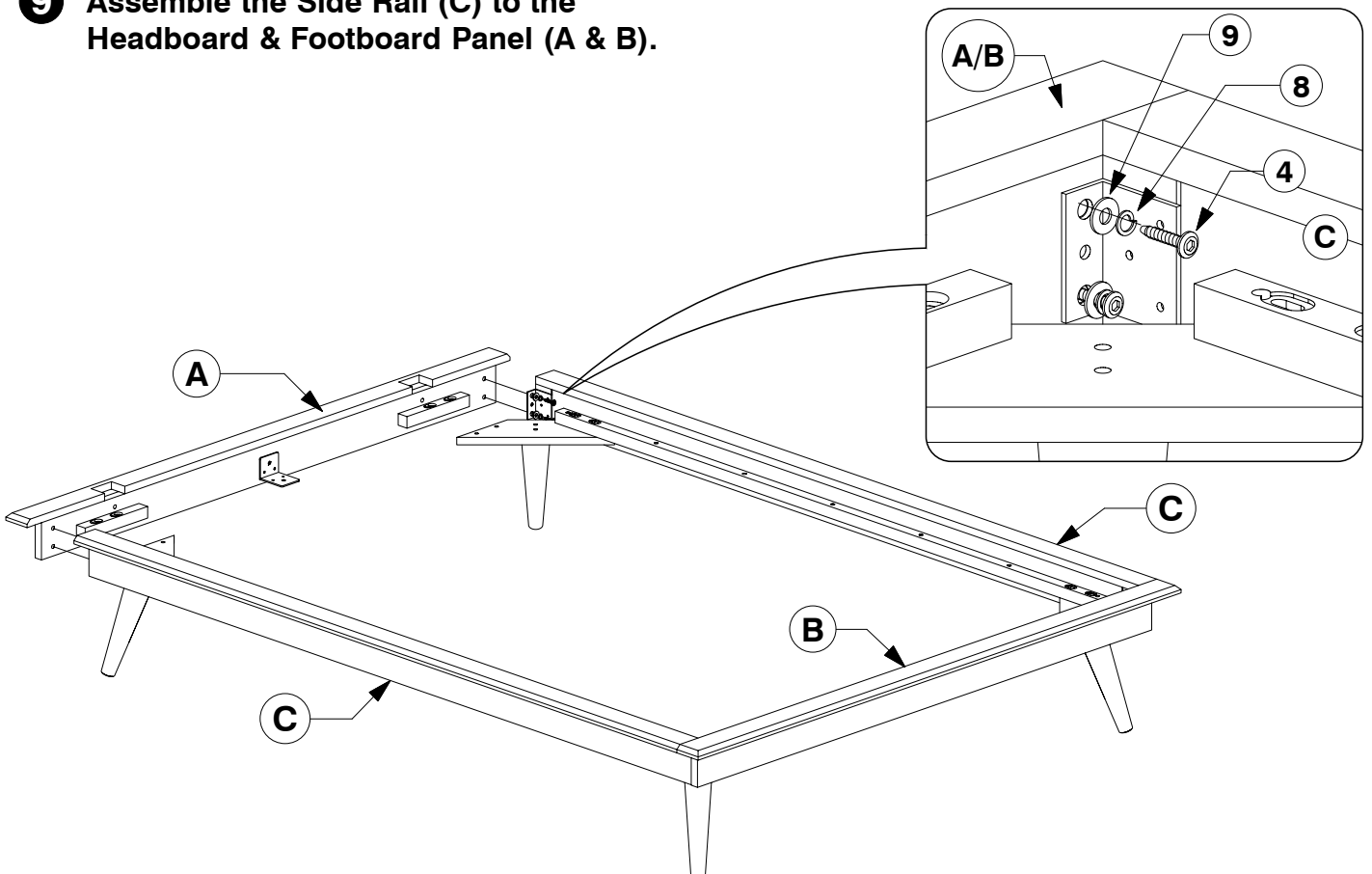

# 0004 Full Bed

## Assembly Instructions

WI-0819

- 10** Bolt the Support Panel (G) to the Headboard & Footboard Panel (A & B).

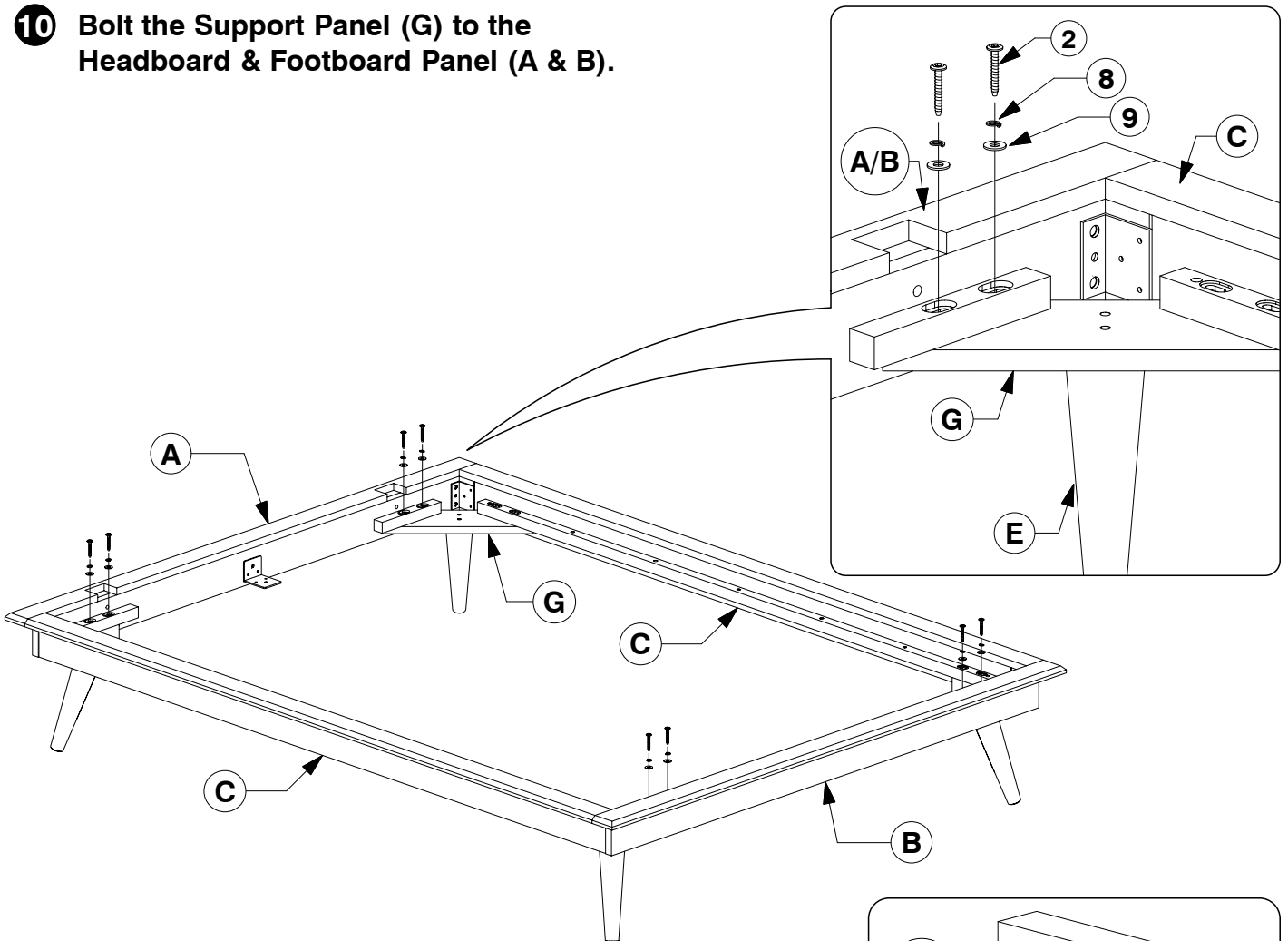

- 11** Bolt the Long Support (D) to the Center Rail Brackets (13) on the Headboard & Footboard Panel (A & B).

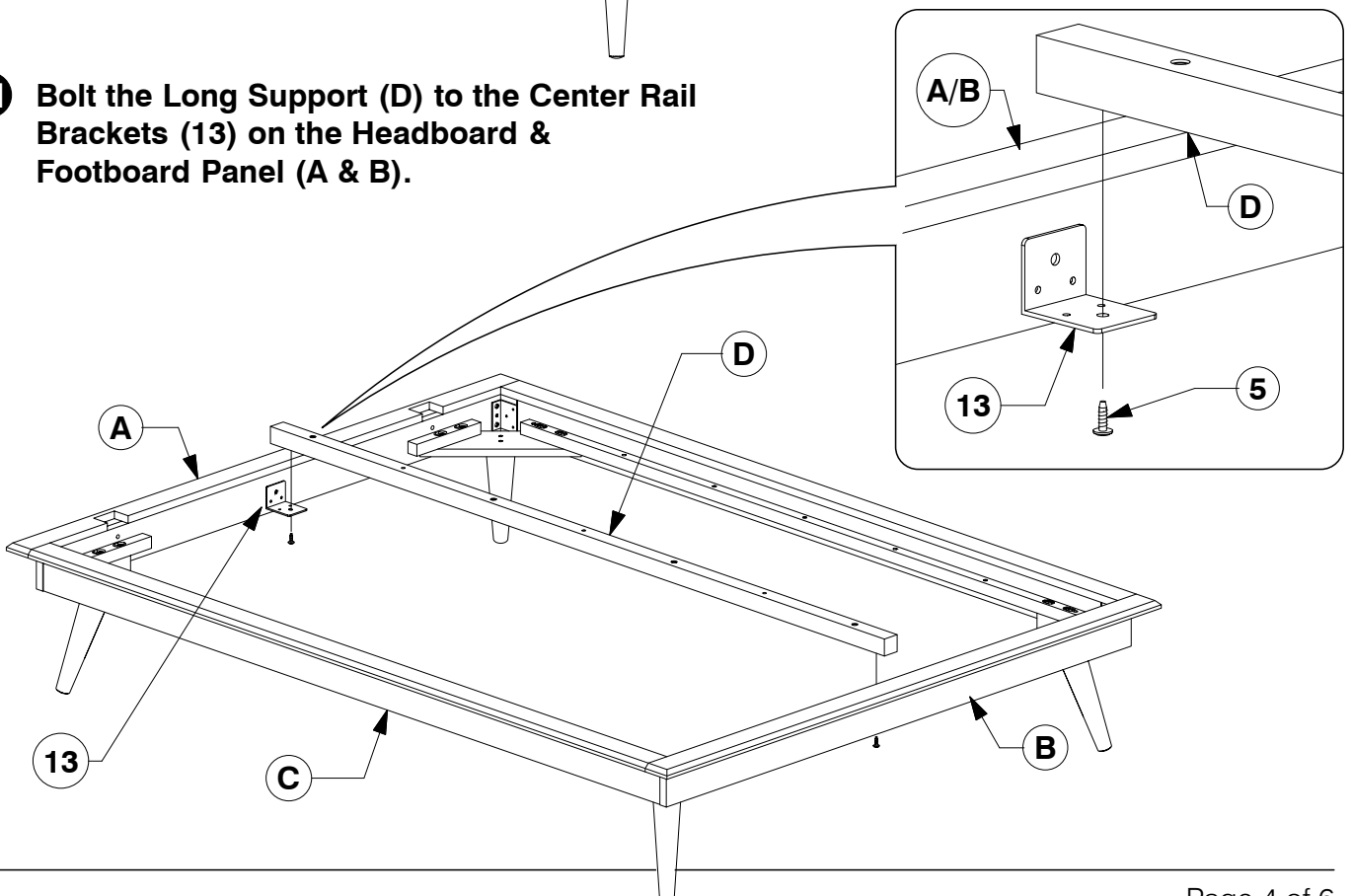

# 0004 Full Bed

## Assembly Instructions

WII-0819

- 12** Fit the first 3 Slats and assemble the Support Leg (F) to the Bed Slat (H). Bolt & screw the Bed Slats (H) to the Side Rail (C) & Long Support (D).

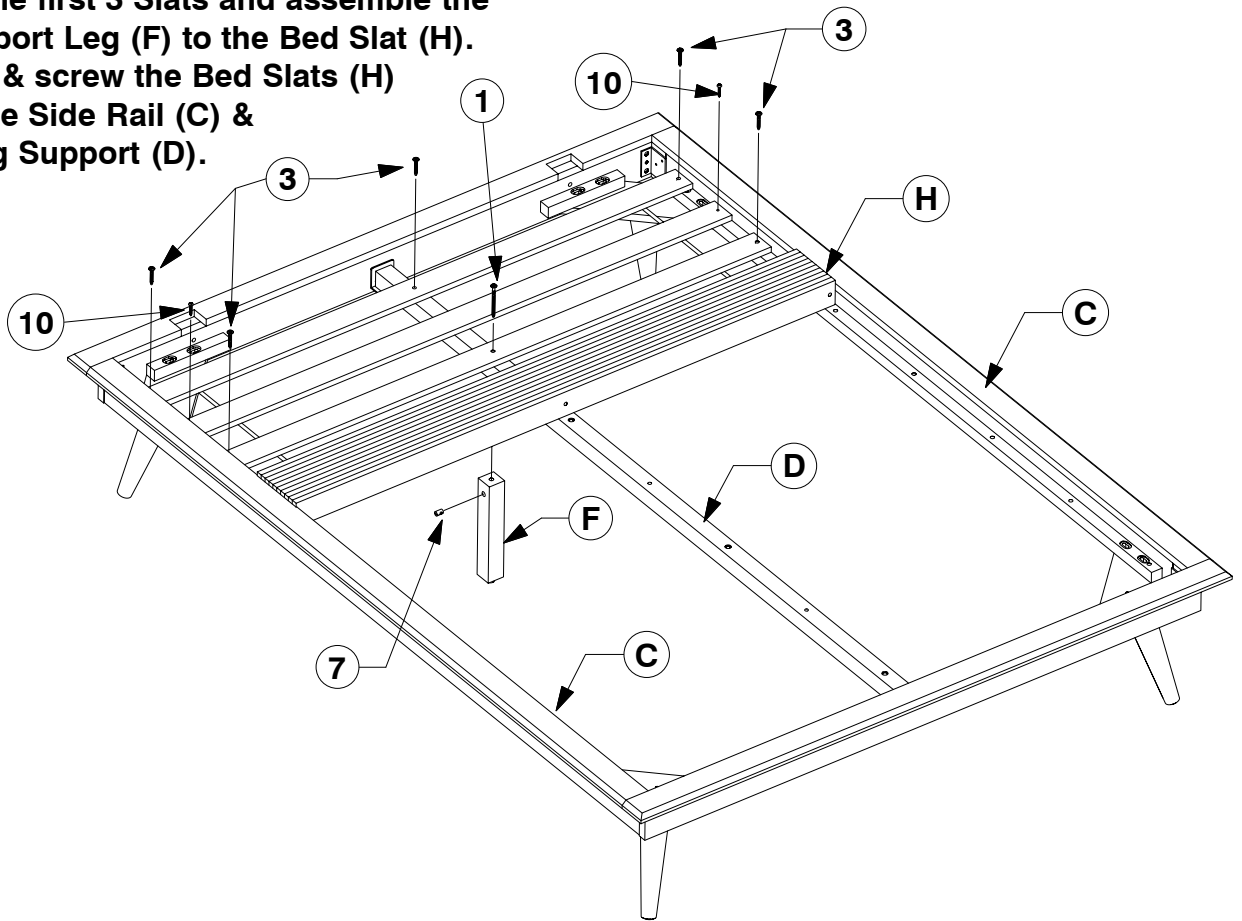

- 13** Fit the other Slats out and assemble the Support Leg (F) to the Bed Slat (H). Bolt & screw the Bed Slats (H) to the Side Rail (C) & Long Support (D).

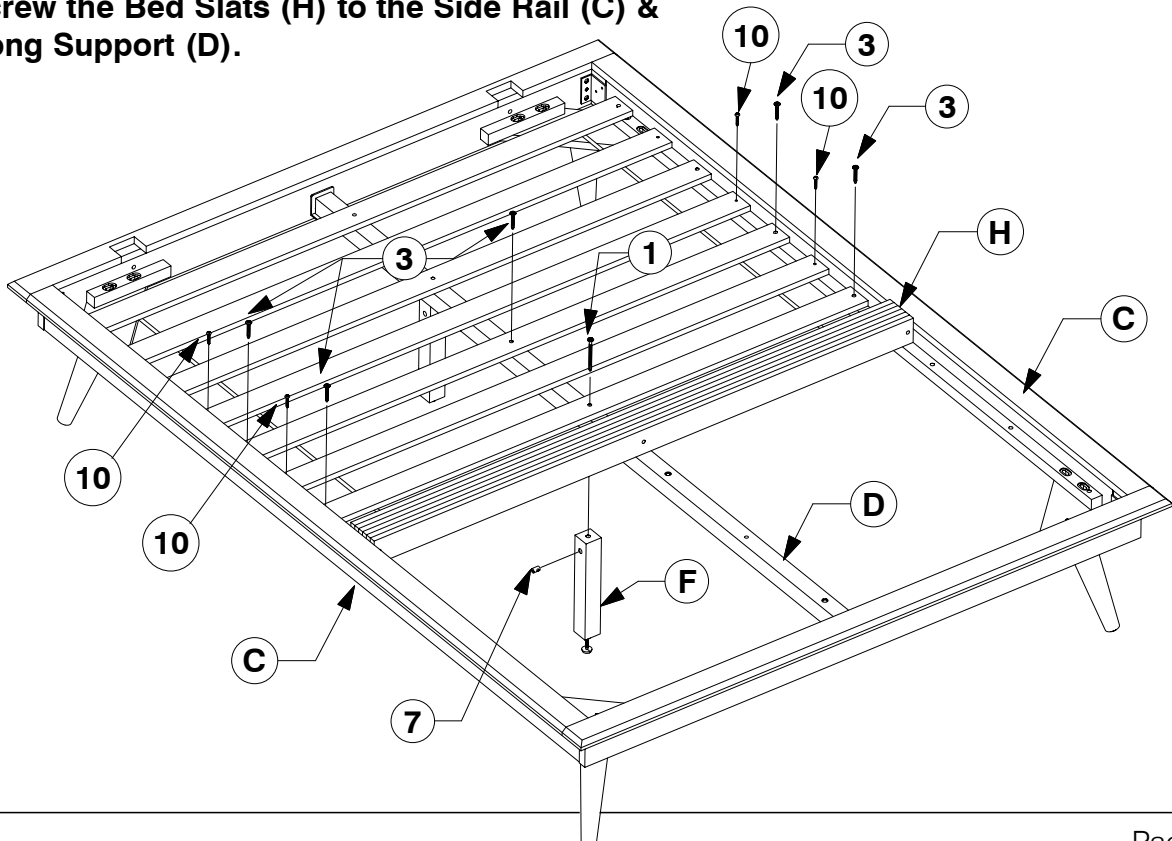

# 0004 Full Bed

## Assembly Instructions

W11-0819

- 14** Fit the other Slats out and assemble the Support Leg (F) to the Bed Slat (H). Bolt & screw the Bed Slats (H) to the Side Rail (C) & Long Support (D).

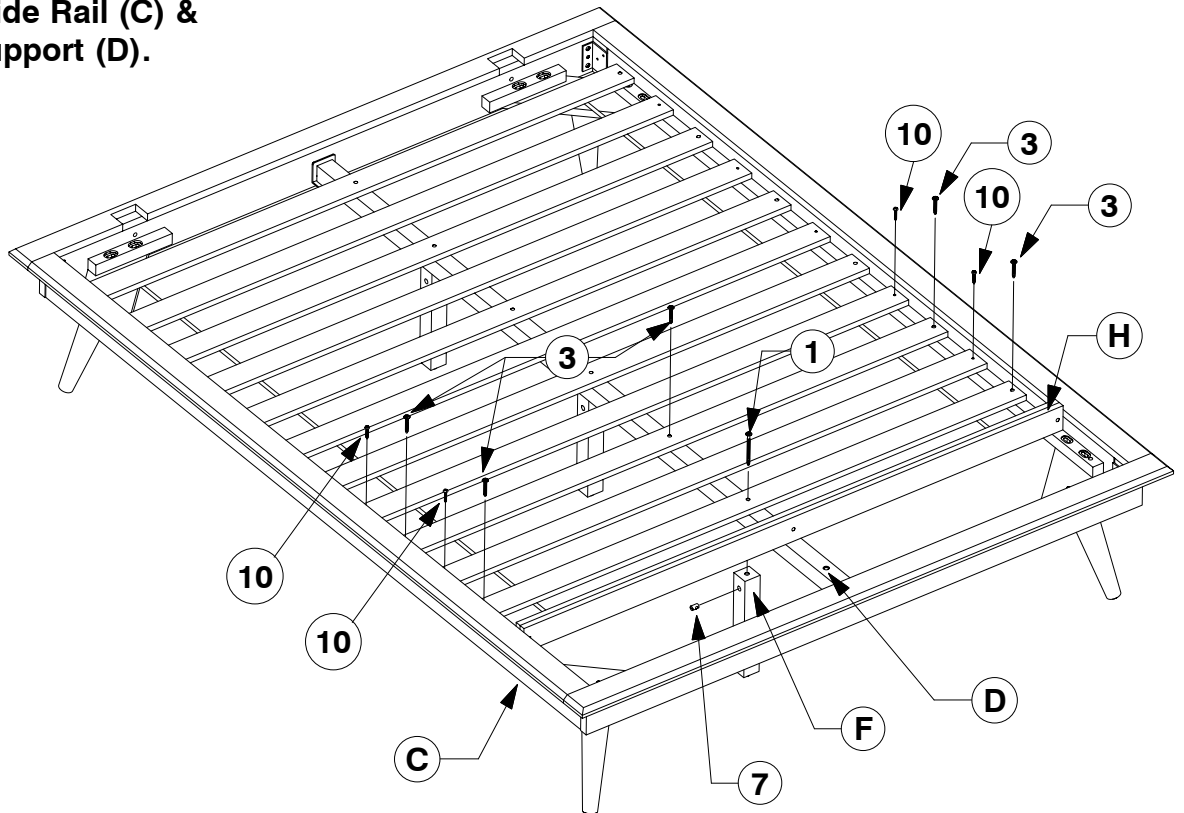

- 15** Bolt & screw the remaining Bed Slats (H) to the Side Rail (C).

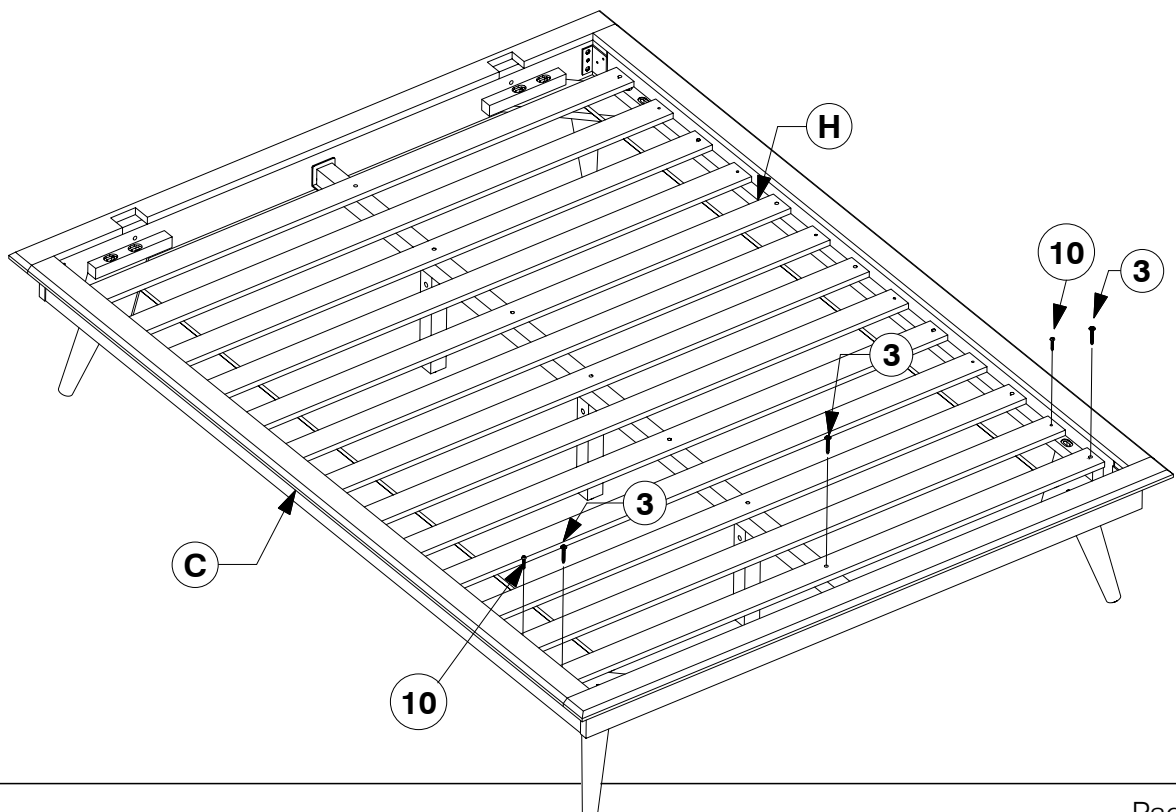

# 0005-1 King Headboard

## Assembly Instructions

WI-0622

### 1 Parts List



**A** Headboard Panel x 1

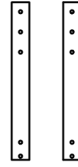

**B** Support Bar x 2

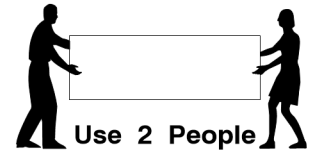

### 2 Hardware List



**1** M6 x 35mm JCB x 10



**2** Spring Washer x 10



**3** Flat Washer x 10



**4** Allen Key x 1

**Note:** Do not assemble using power tools. This can cause the bolts to be overtightened

### 3 Assemble the Support Bars (B) to the Headboard Panel.

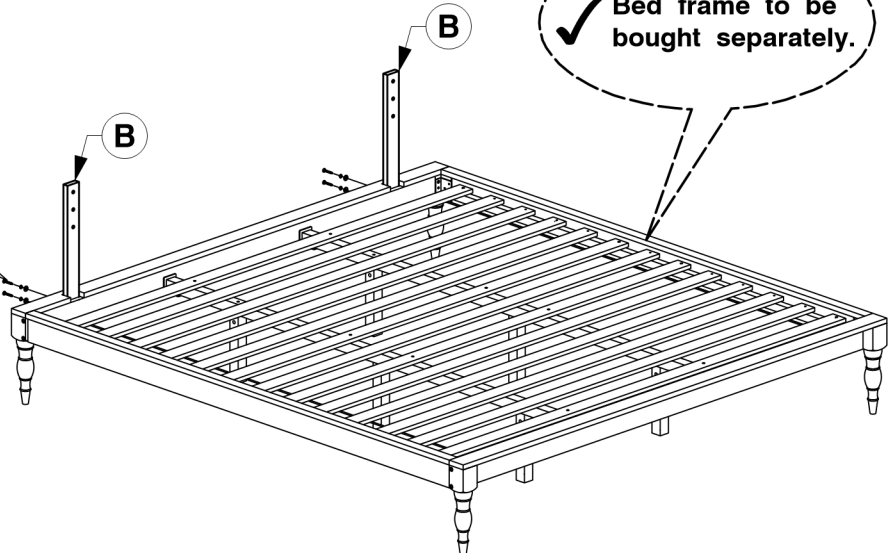
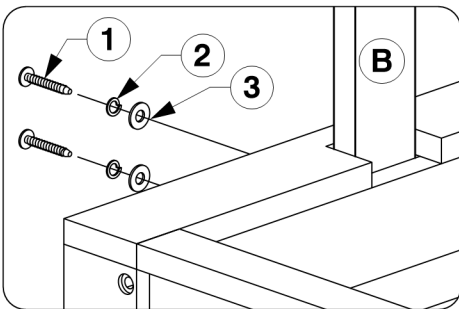

### 4 Assemble the Headboard Panel (A) to the Support Bars (B).

