

9766 Full / Queen Headboard

Assembly Instructions

WI-0622

1 Parts List

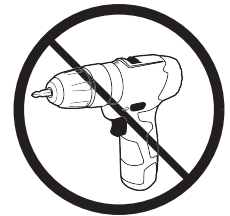
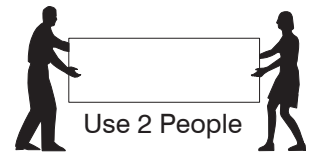
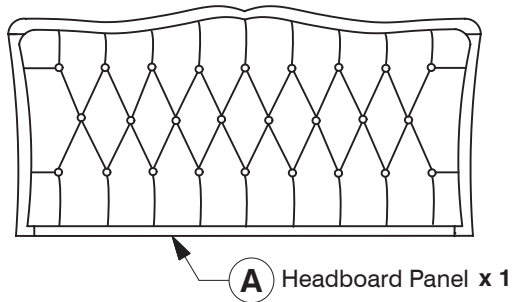

2 Hardware List

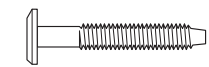

1 M6 x 35mm JCB x 10



2 Spring Washer x 10



3 Flat Washer x 10



4 Allen Key x 1

Note: Do not assemble using power tools. This can cause the bolts to be overtightened.

3 Assemble the Support Bars (B) to the Headboard Panel.

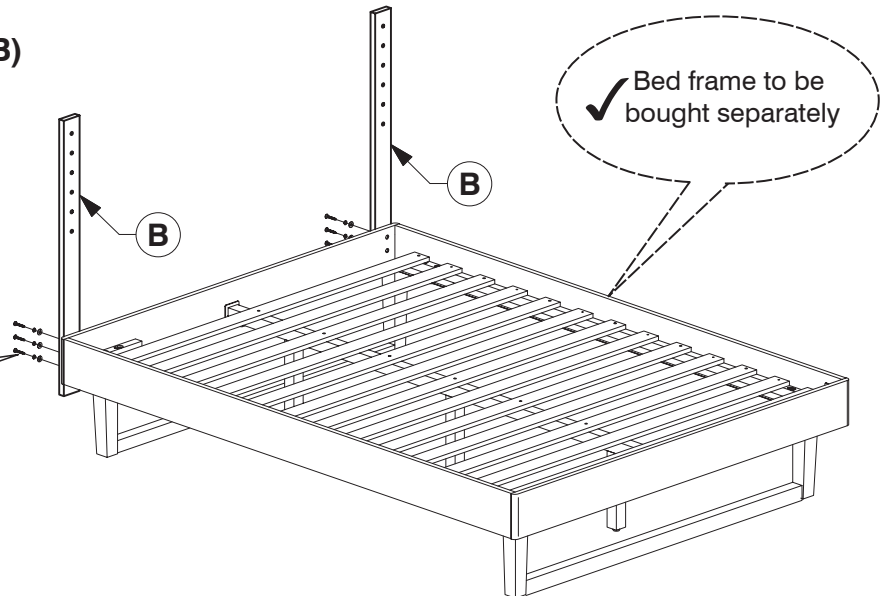
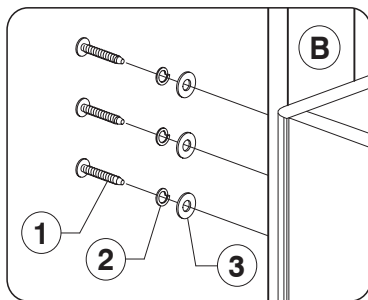

4 Assemble the Headboard Panel (A) to the Support Bars (B).

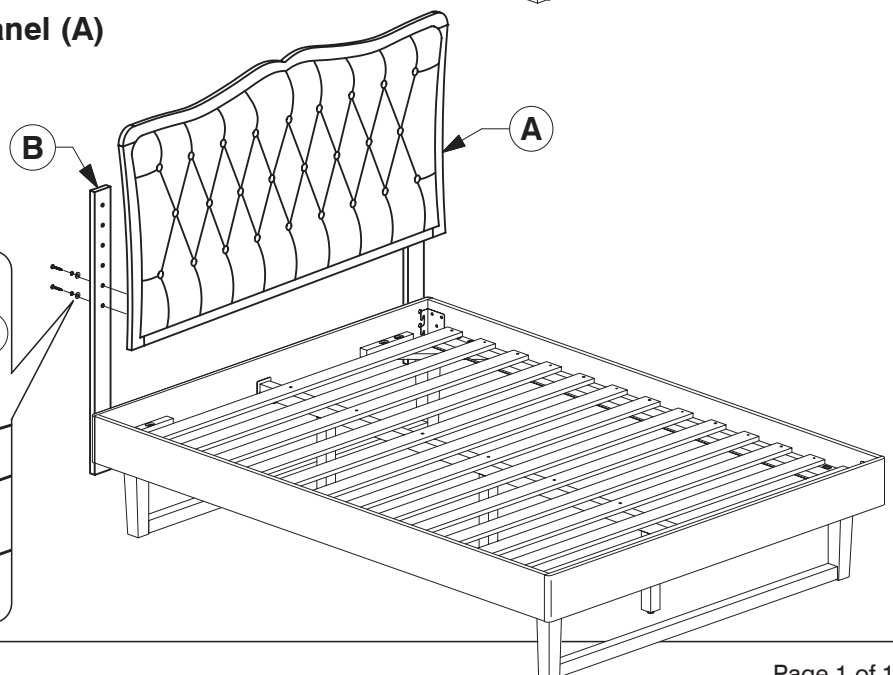
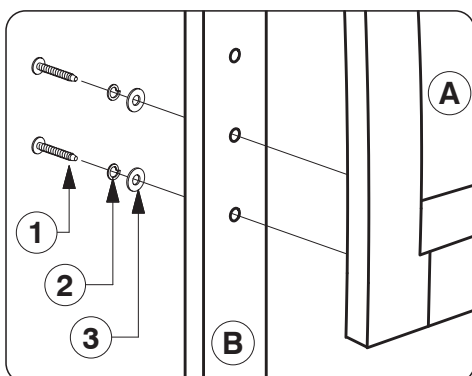

Queen Bed

Assembly Instructions

0818

1 Assembled View

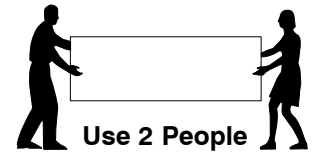
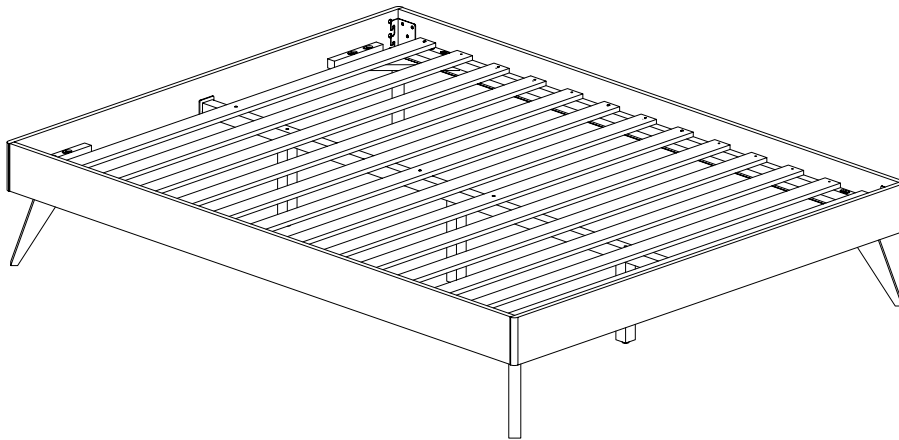

Note: Do not assemble using power tools. This can cause the bolts to be overtightened

2 Parts List

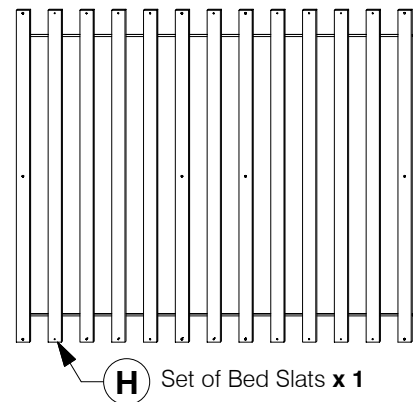
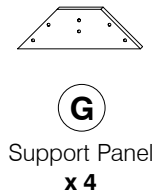
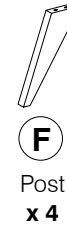
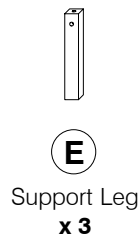
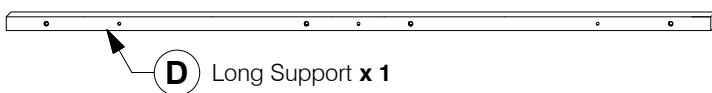
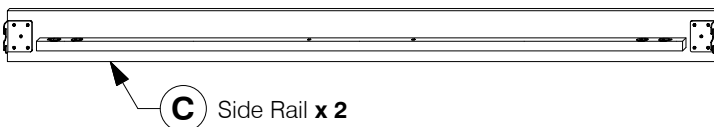
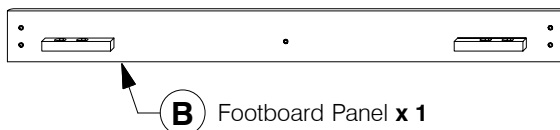
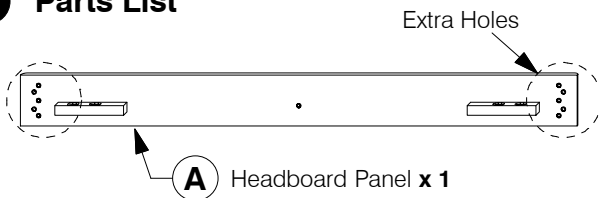

3 Hardware List

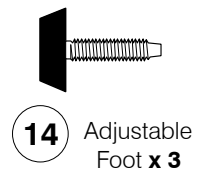
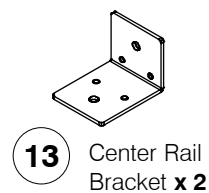
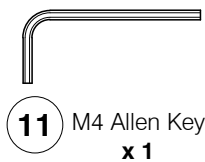
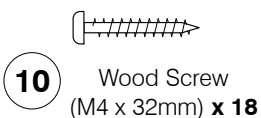
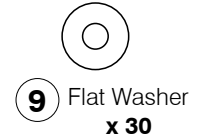
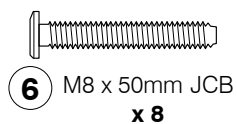
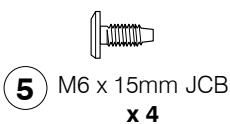
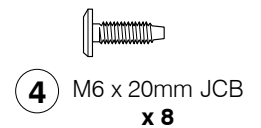
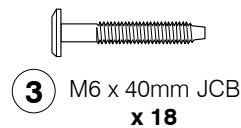
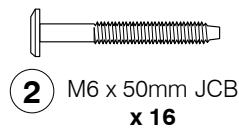
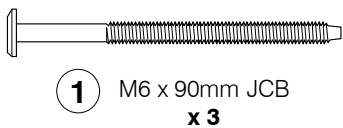

Queen Bed

Assembly Instructions

0818

- 4** Assembled the Support Leg (E) to the Long Support (D).

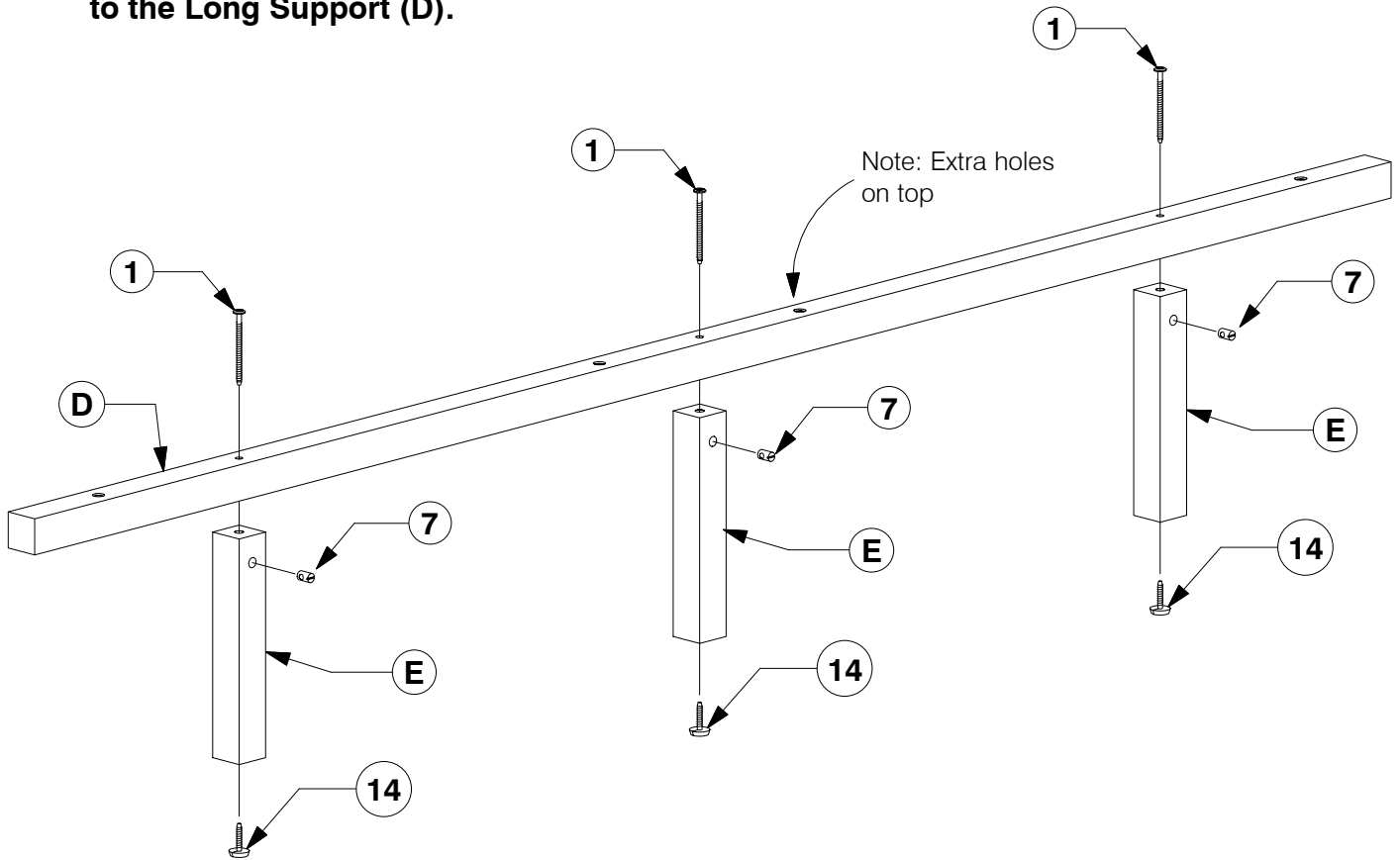

- 5** Fit the Post (F) to the Support Panel (G).

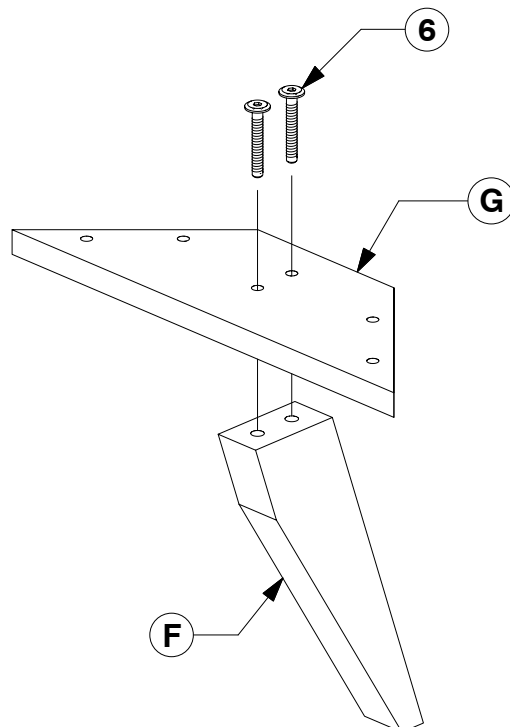

Queen Bed

Assembly Instructions

0818

- 6** Fit the Center Rail Bracket to the Headboard Panel (A).

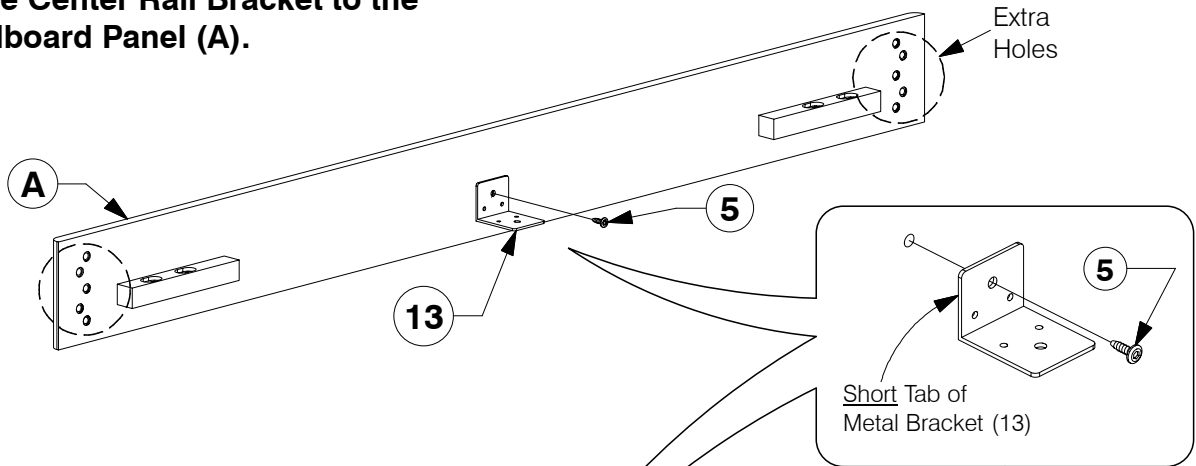

- 7** Fit the Center Rail Bracket to the Footboard Panel (B).

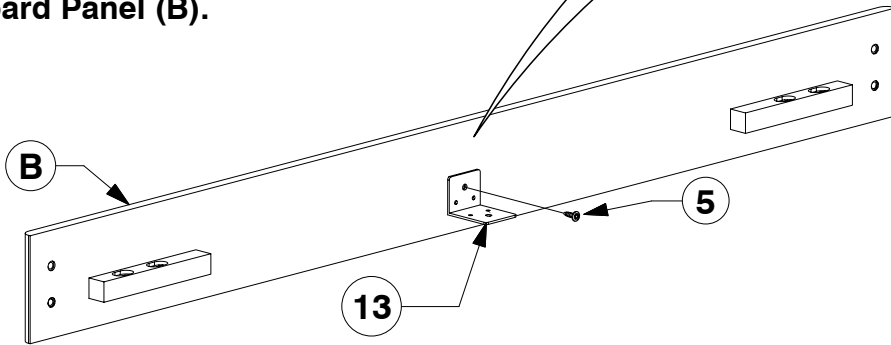

- 8** Bolt the assembled Support Panel (G) to the Side Rail (C).

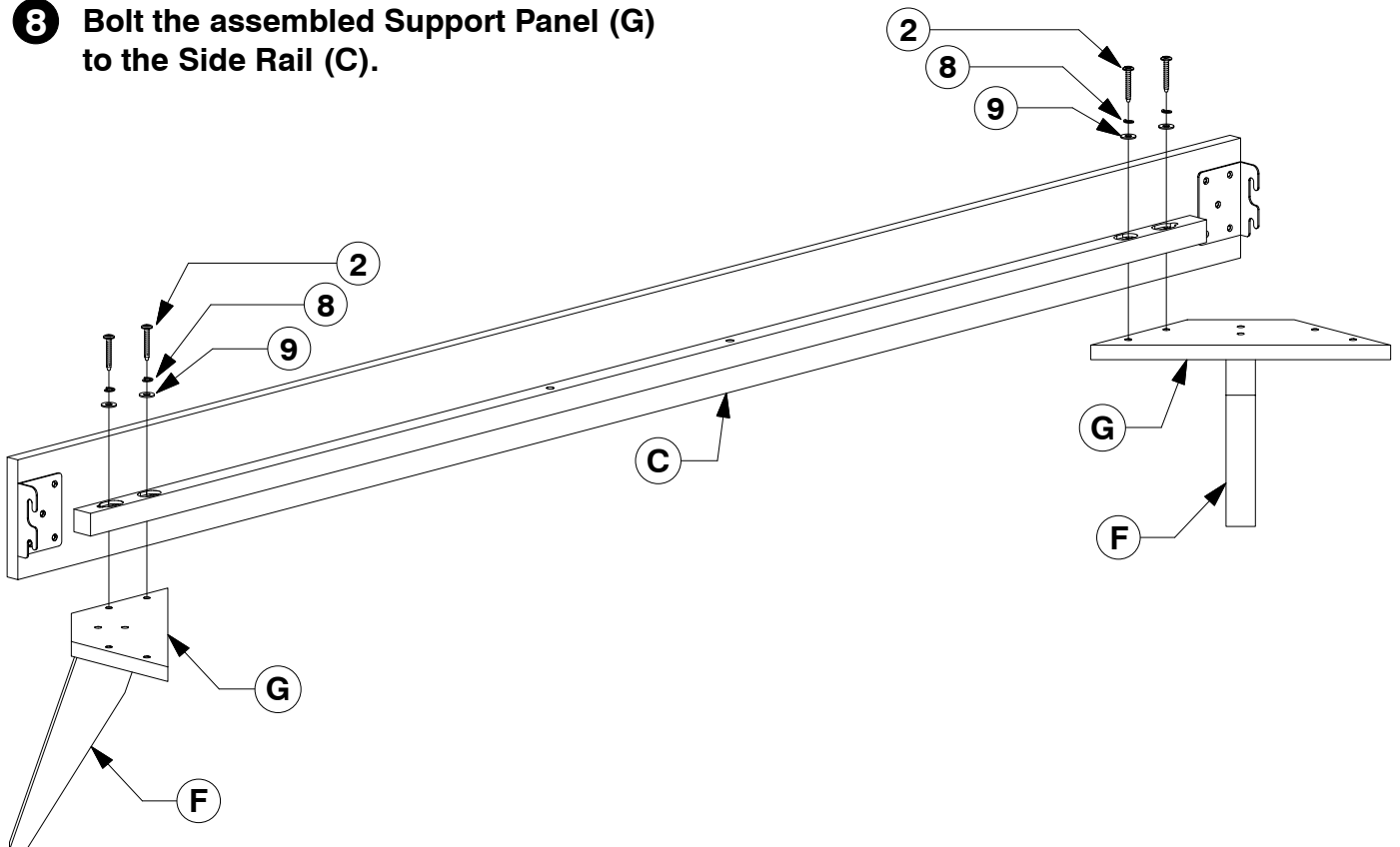

Queen Bed

Assembly Instructions

0818

- 9** Assemble the Side Rail (C) to the Headboard and Footboard Panel (A & B).

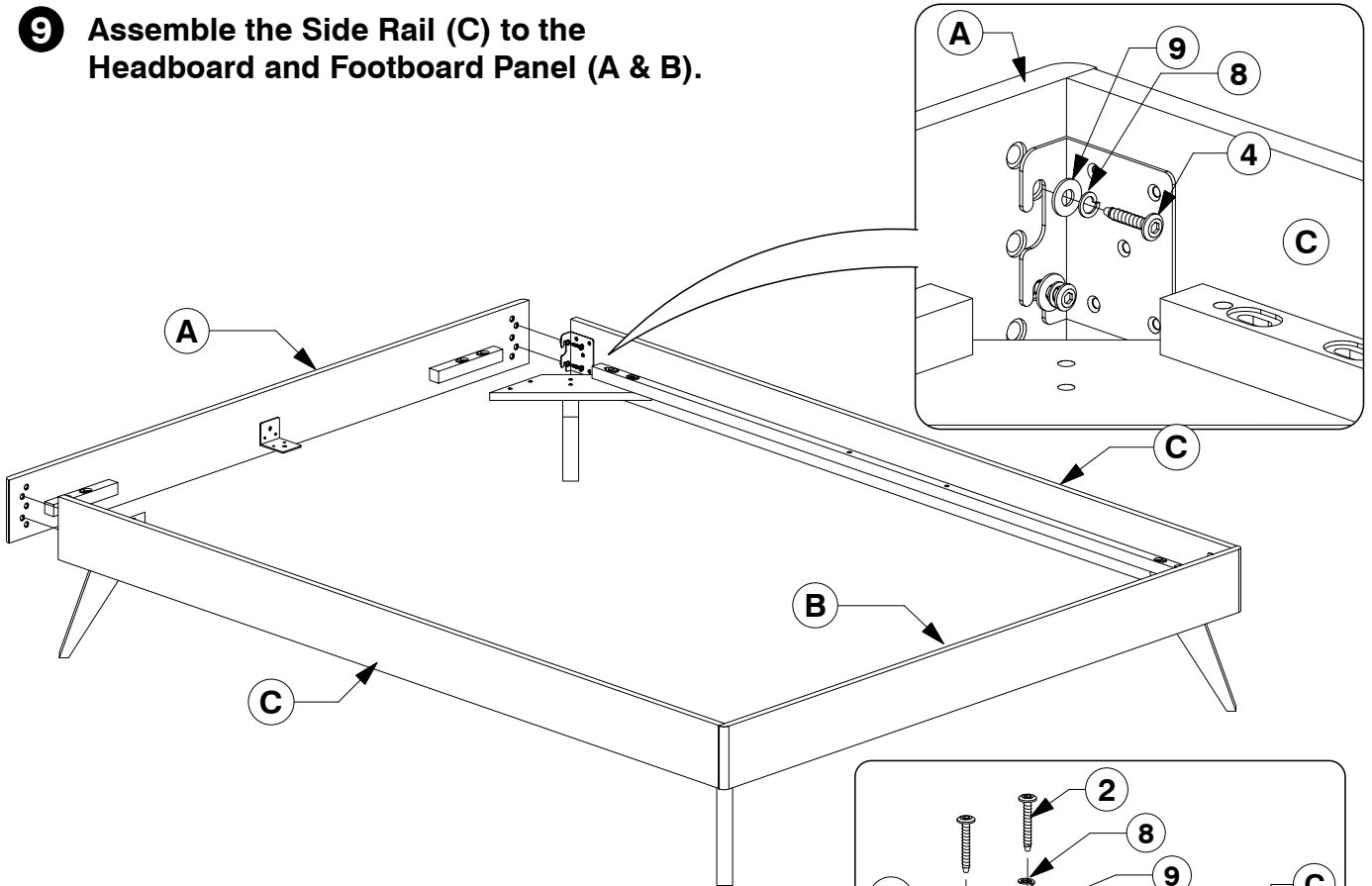

- 10** Bolt the assembled Support Panel (G) to the Headboard and Footboard Panel (A & B).

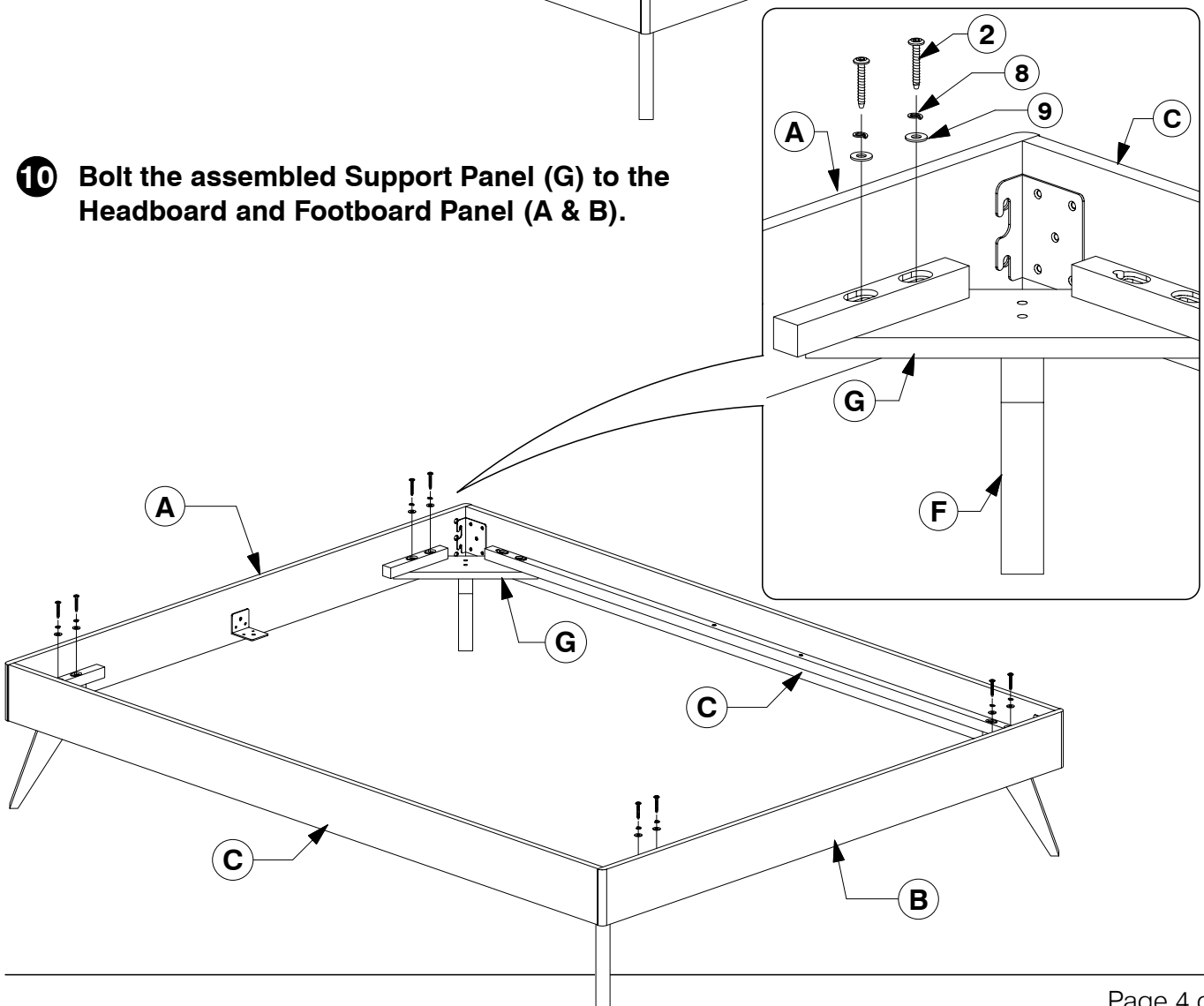

Queen Bed

Assembly Instructions

0818

- 11** Bolt the Long Support (D) to the Center Rail Brackets (13) on the Headboard and Footboard Panel (A & B).

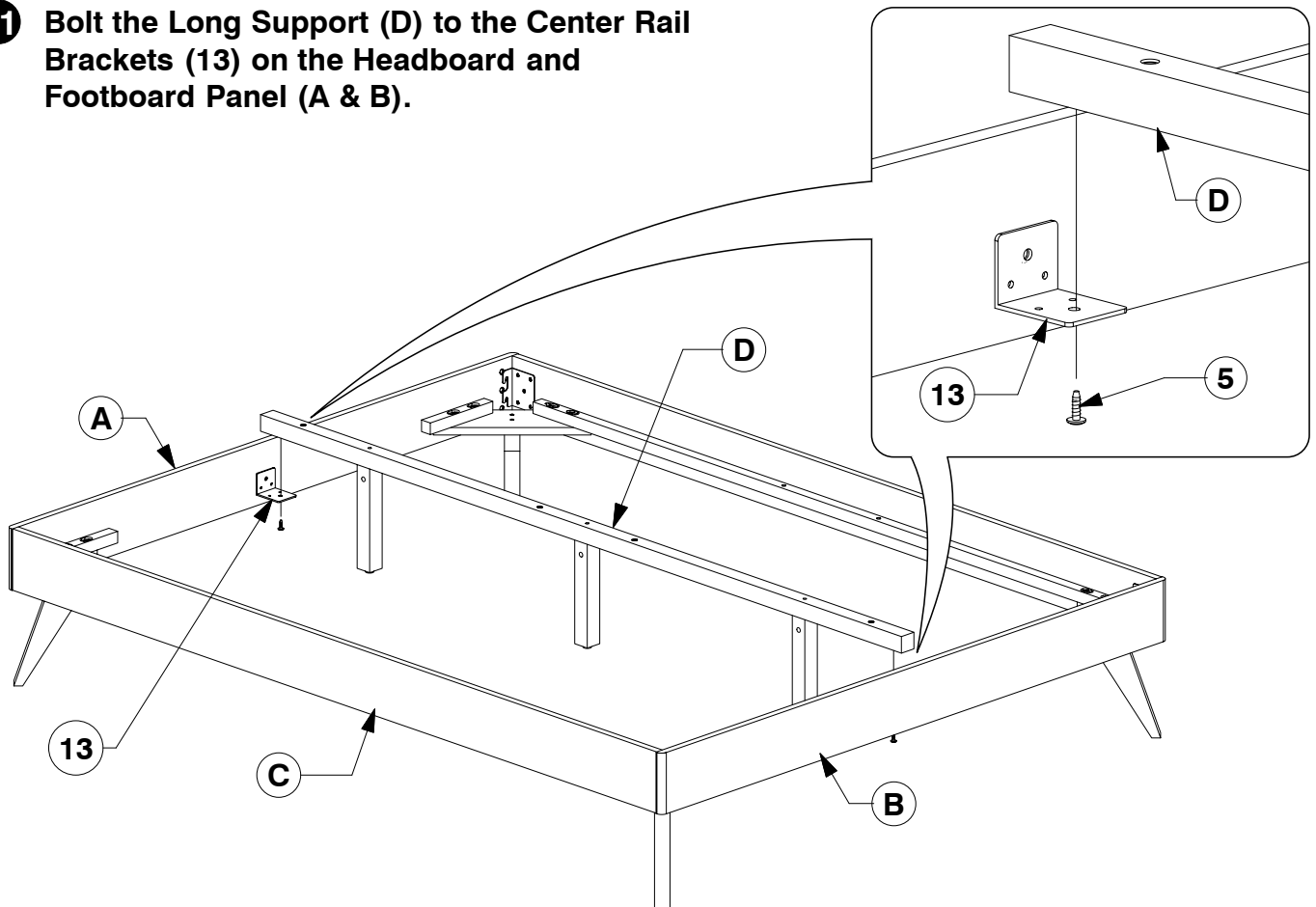

- 12** Bolt & screw the Bed Slats (H) to the Side Rail (C).

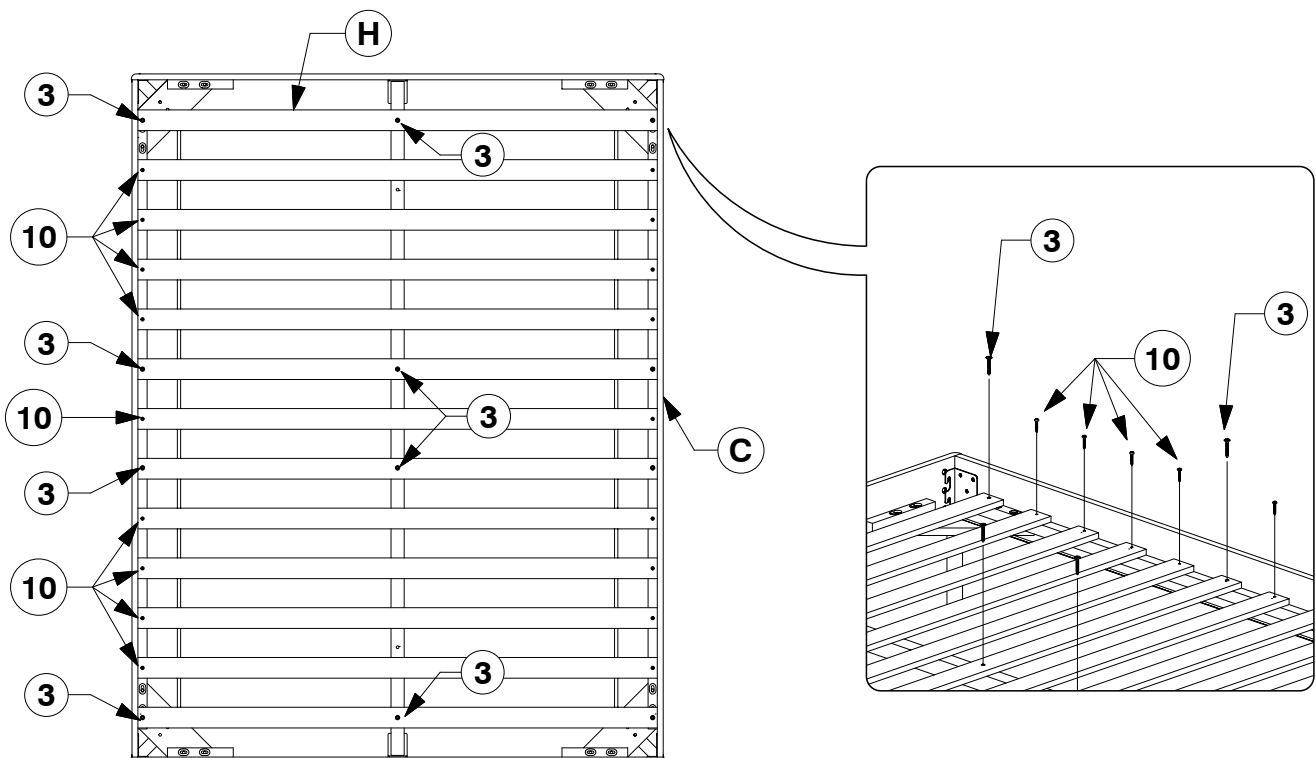

9766 King Headboard

Assembly Instructions

WI-0622

1 Parts List

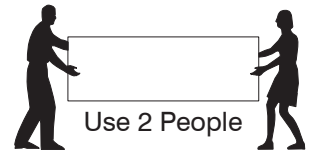
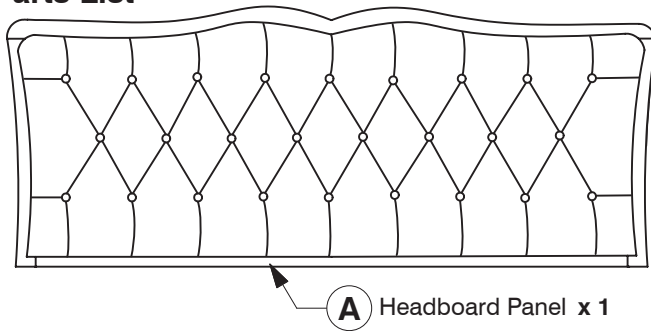

Note: Do not assemble using power tools. This can cause the bolts to be overtightened.

2 Hardware List

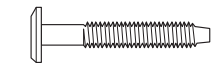

1 M6 X 35mm JCB x 10



2 Spring Washer x 10



3 Flat Washer x 10



4 Allen Key x 1

3 Assemble the Support Bars (B) to the Headboard Panel.

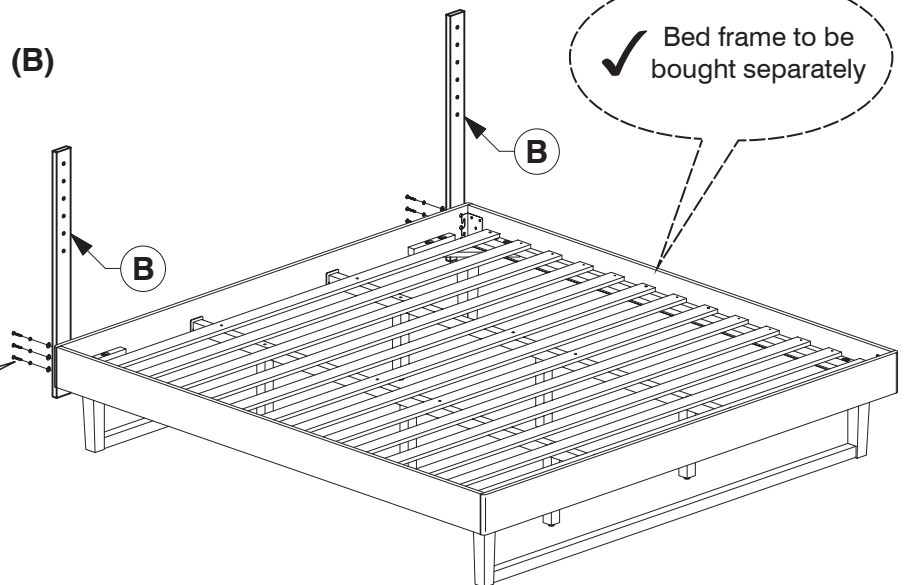
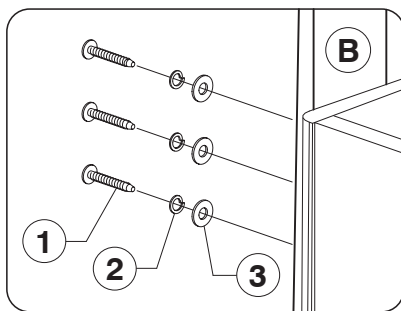

4 Assemble the Headboard Panel (A) to the Support Bars (B).

