

# 9766 Full / Queen Headboard

Assembly Instructions

WI-0622

## 1 Parts List

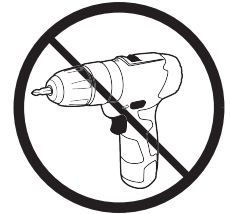
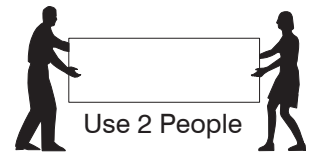
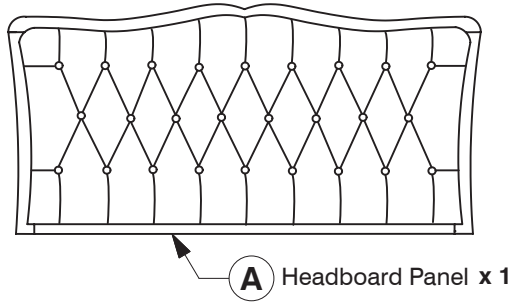

## 2 Hardware List

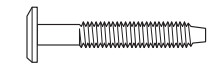

**1** M6 x 35mm JCB x 10



**2** Spring Washer x 10



**3** Flat Washer x 10



**4** Allen Key x 1

Note: Do not assemble using power tools. This can cause the bolts to be overtightened.

## 3 Assemble the Support Bars (B) to the Headboard Panel (A).

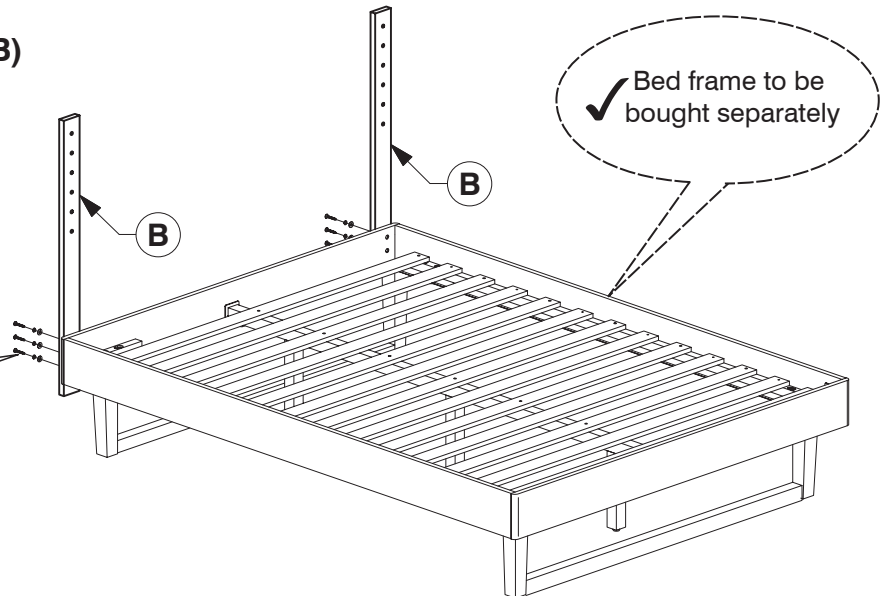
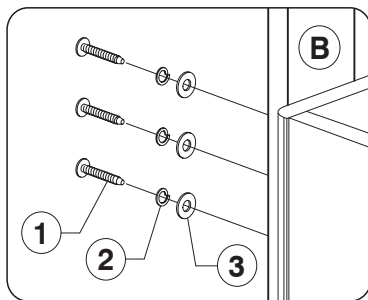

## 4 Assemble the Headboard Panel (A) to the Support Bars (B).

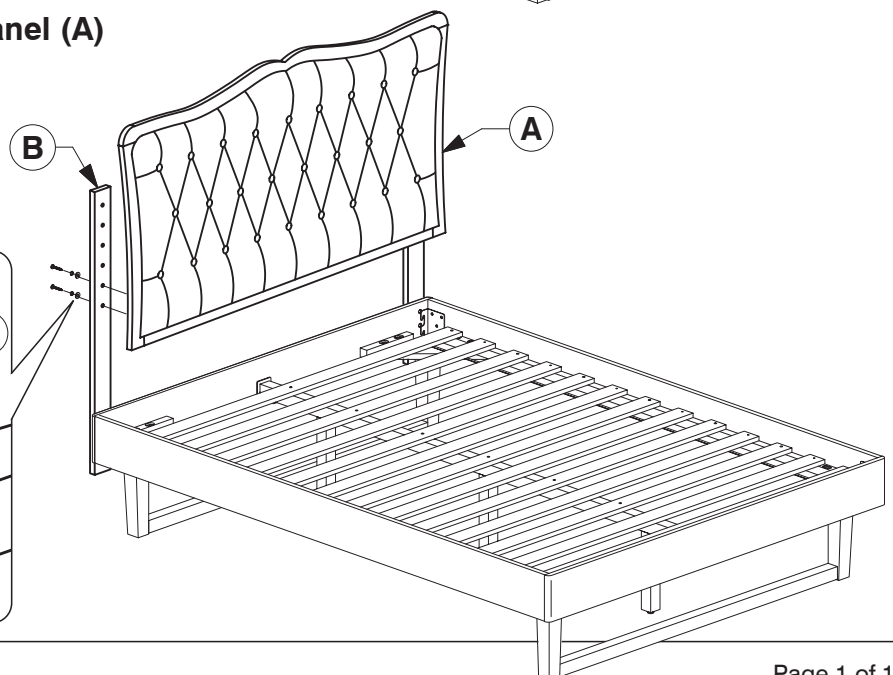
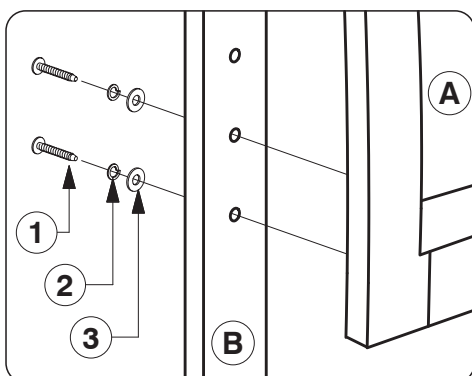

# 9765 Full / Queen Headboard

Assembly Instructions

WI-0622

## 1 Parts List

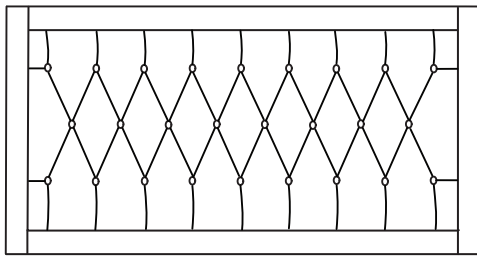

**A**  
Headboard Panel  
x 1

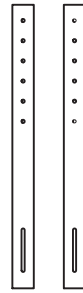

**B**  
Support Bars  
x 2

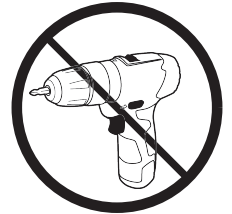
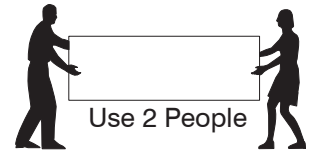

## 2 Hardware List



**1** M6 x 35mm JCB  
x 10



**2** Spring Washer  
x 10



**3** Flat Washer  
x 10



**4** Allen Key  
x 1

Note: Do not assemble using power tools. This can cause the bolts to be overtightened.

## 3 Assemble the Support Bars (B) to the Headboard Panel (A) to the Headboard Panel.

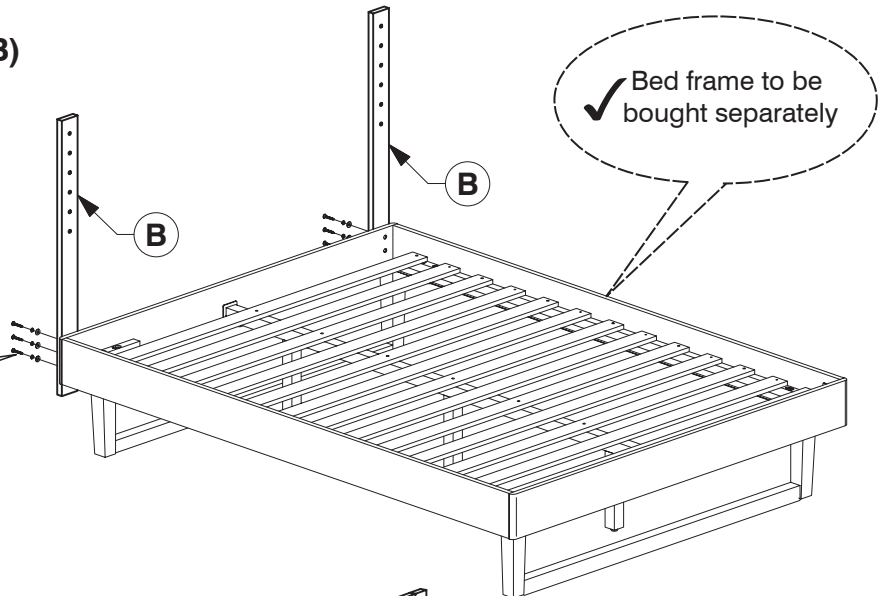
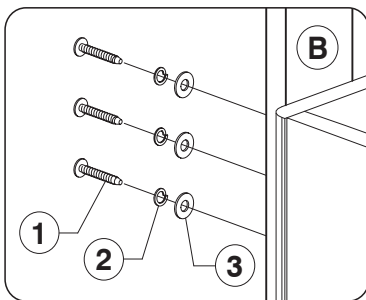

## 4 Assemble the Headboard Panel (A) to the Support Bars (B).

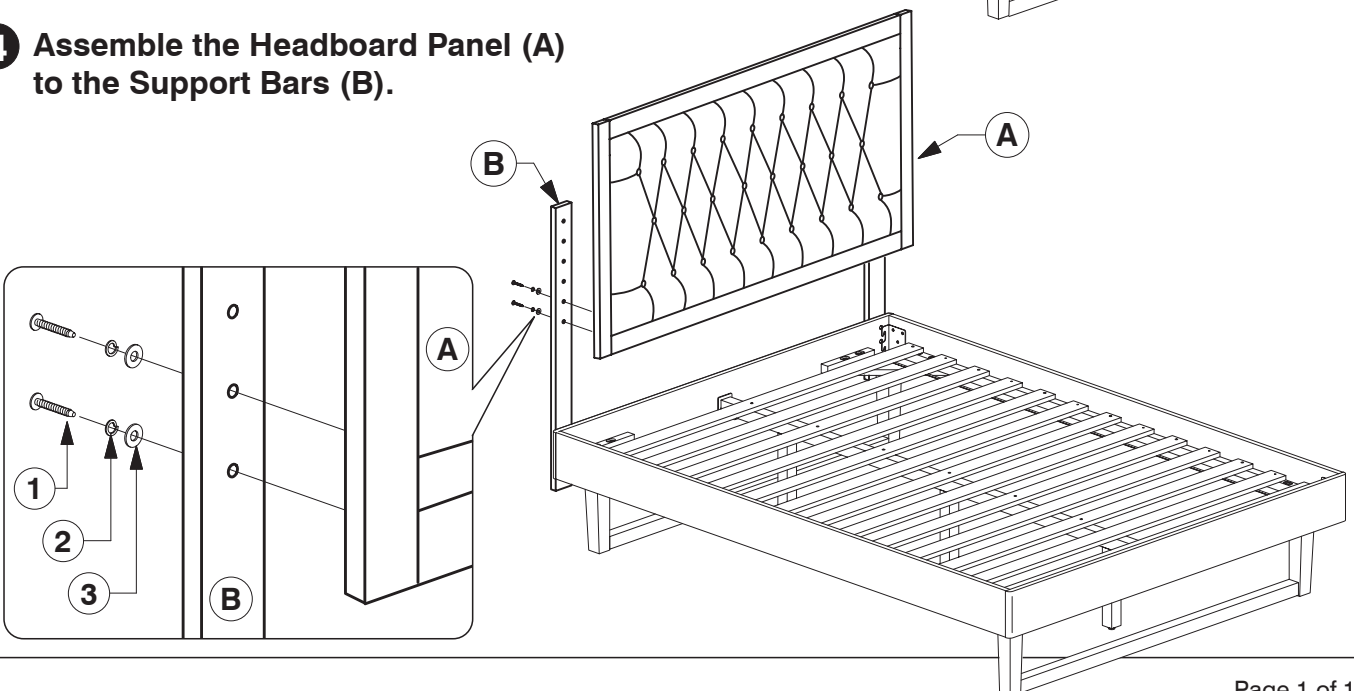

# 0012 Queen Bed

## Assembly Instructions

WII-0619

### 1 Assembled View

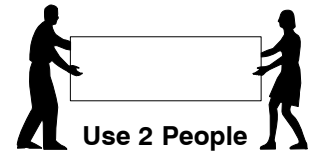
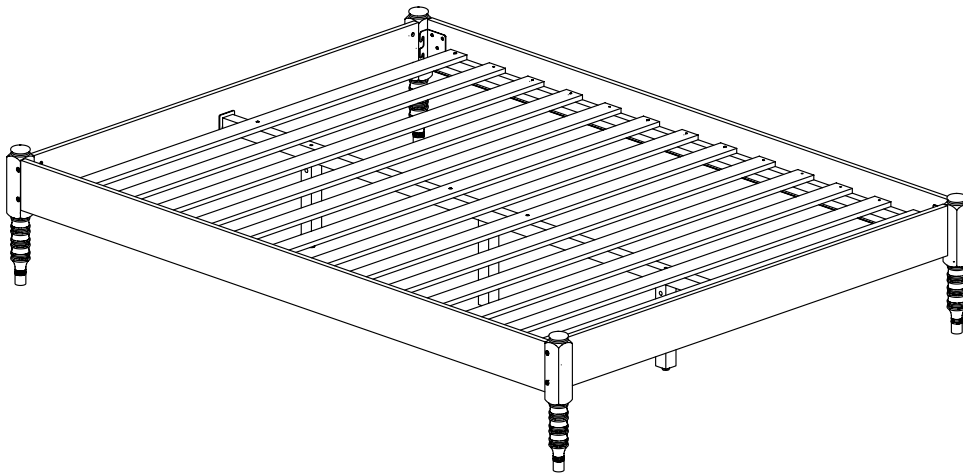

**Note:** Do not assemble using power tools. This can cause the bolts to be overtightened

### 2 Parts List

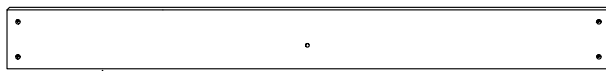

**A** Head / Footboard Panel x 2

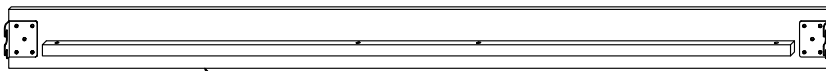

**B** Side Rail x 2

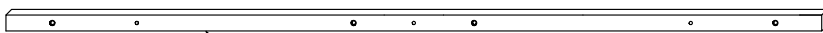

**C** Long Support x 1



**D**  
Support Leg  
x 3

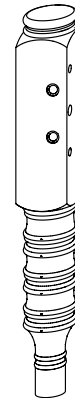

**E**  
Post  
(Left hand)  
x 2

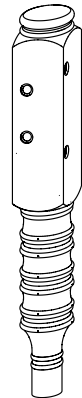

**F**  
Post  
(Right hand)  
x 2

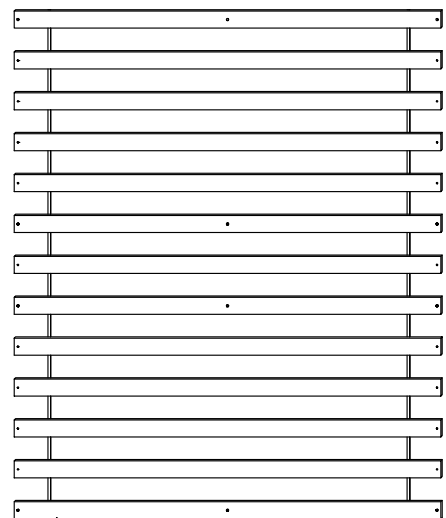

**G** Set of Bed Slats x 1

# 0012 Queen Bed

## Assembly Instructions

WII-0619

### 3 Hardware List



1 M4 Allen Key  
x 1

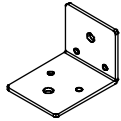

2 Center Rail  
Bracket x 2

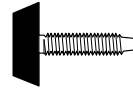

3 Adjustable  
Foot x 3

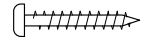

4 Wood Screw  
(M4 x 32mm) x 18



5 Wood Dowel  
(10 x 40mm) x 4



6 Barrel Nut  
x 11



7 Spring Washer  
x 8



8 Flat Washer  
x 8



9 M6 x 15mm JCB  
x 4



10 M6 x 20mm JCB  
x 8



11 M6 x 40mm JCB  
x 12



12 M6 x 90mm JCB  
x 11

### 4 Assembled the Support Leg (D) to the Long Support (C).

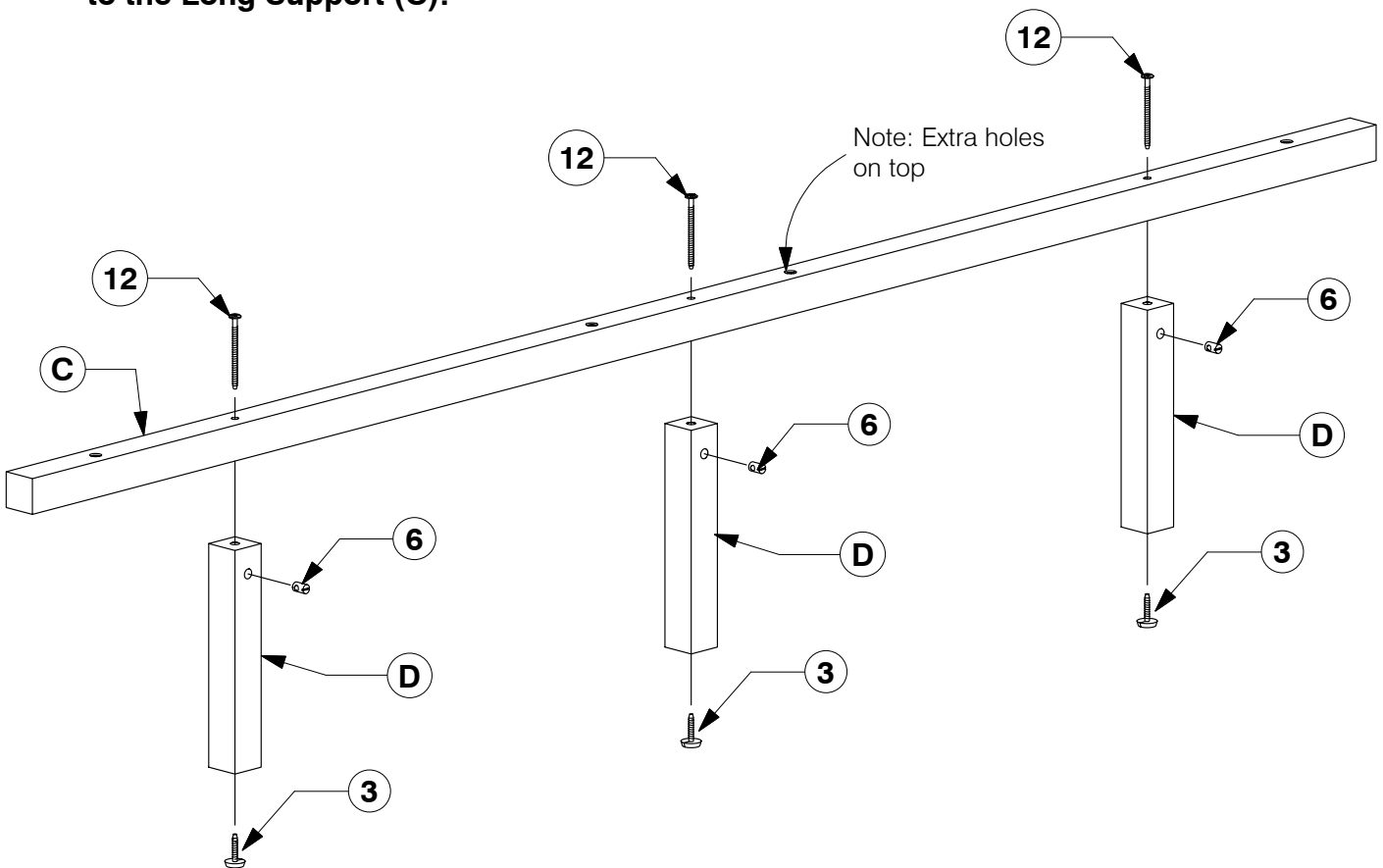

# 0012 Queen Bed

## Assembly Instructions

WII-0619

- 5** Assemble the Post (E & F) to the Head / Footboard Panel (A).  
Fit the Center Rail Bracket to the Head / Footboard Panel (A).

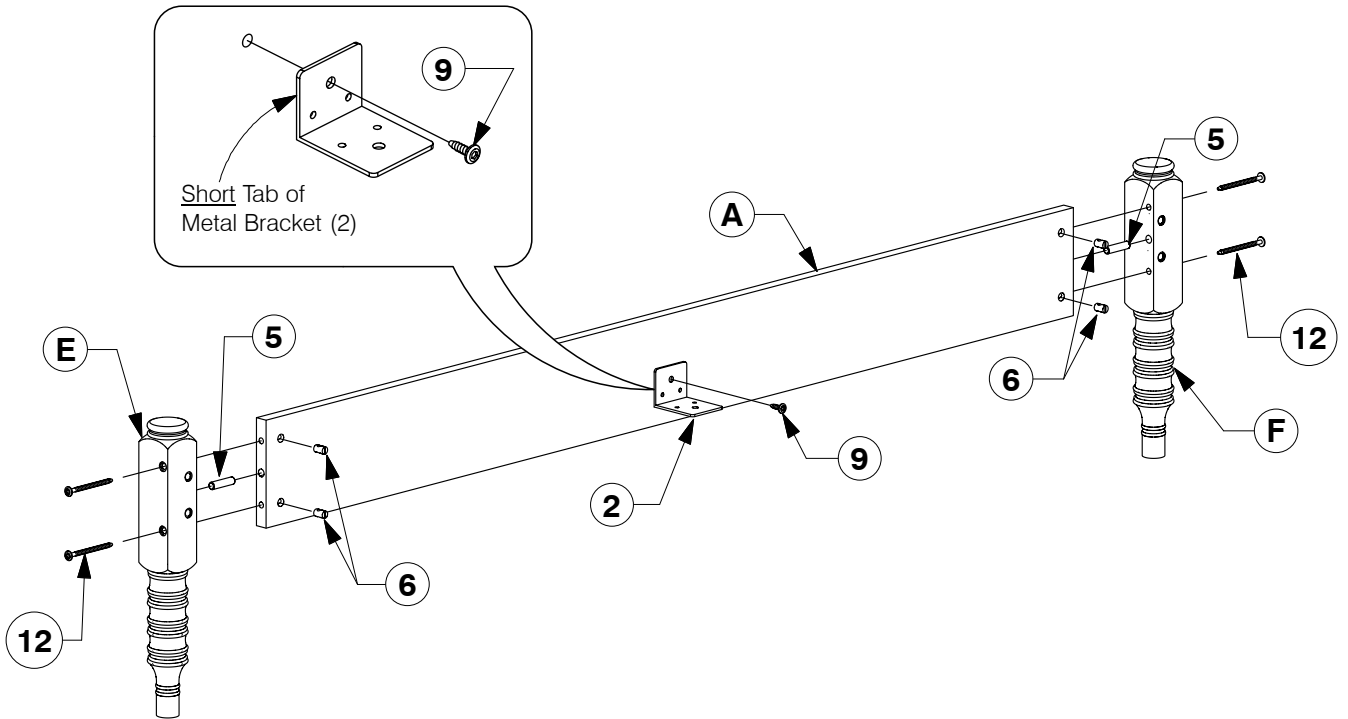

- 6** Assemble the Side Rail (B) to the Headboard / Footboard Panel (A).

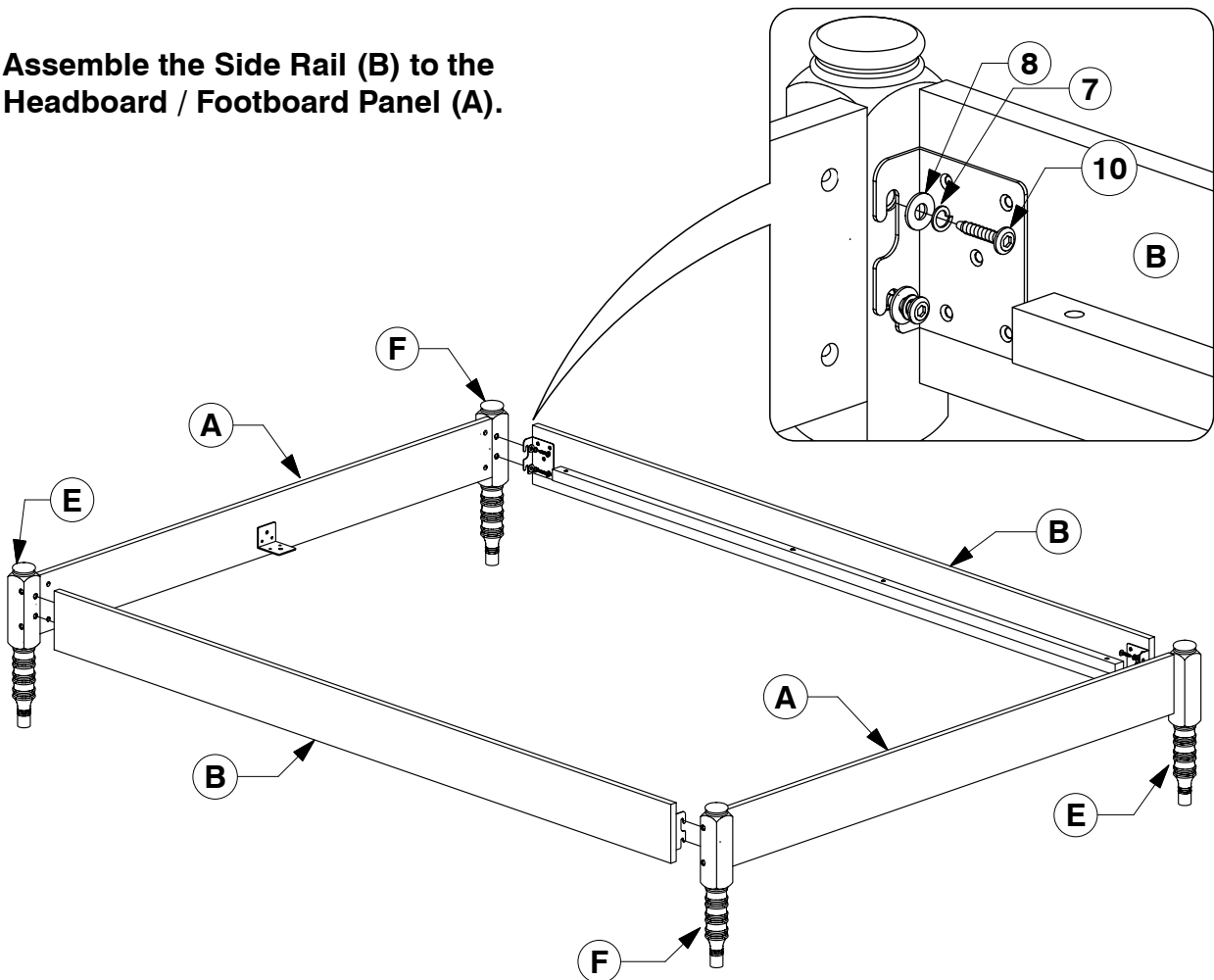

# 0012 Queen Bed

## Assembly Instructions

W11-0619

- 7 Bolt the Long Support (C) to the Center Rail Brackets (2) on the Headboard / Footboard Panel (A).**

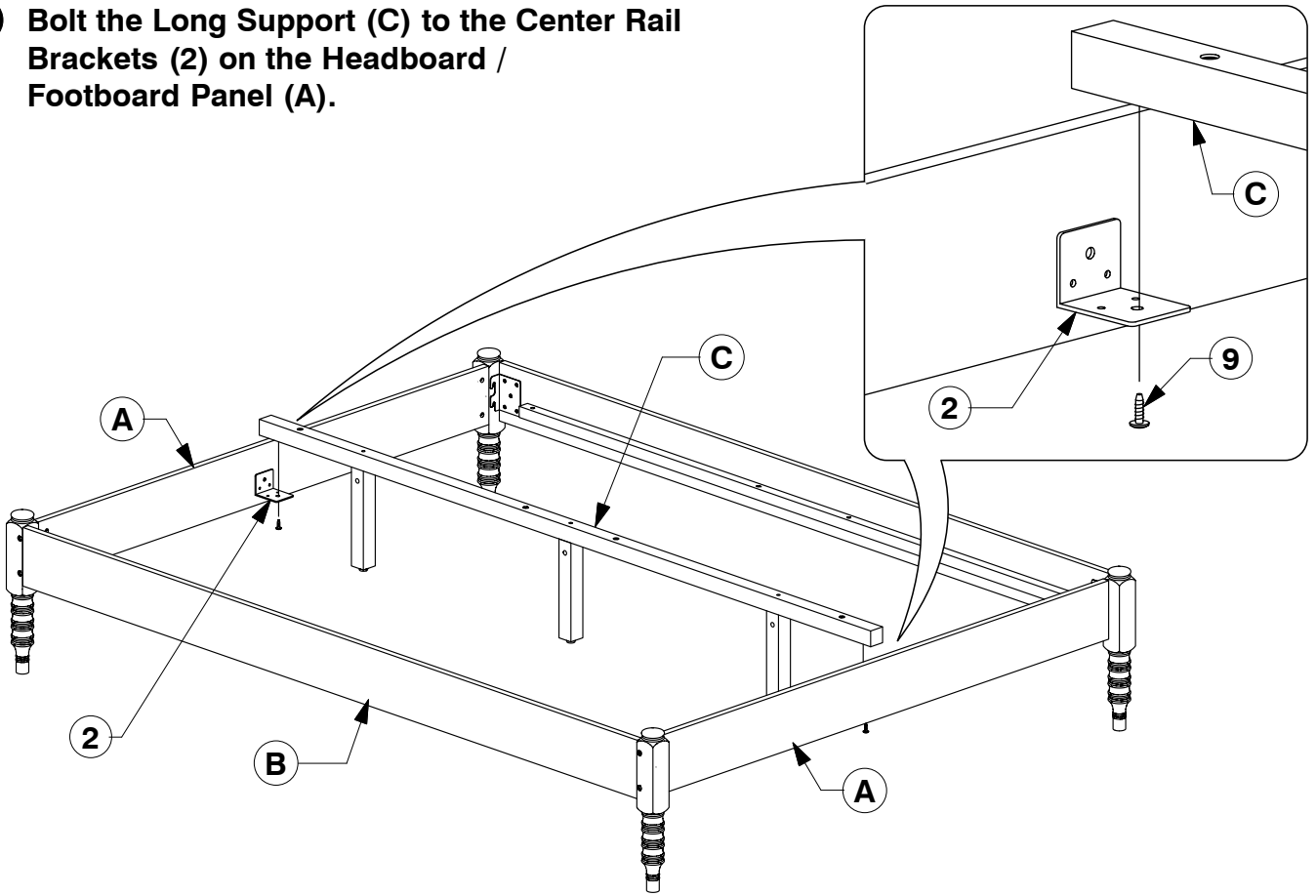

- 8 Bolt & screw the Bed Slats (G) to the Side Rail (B).**

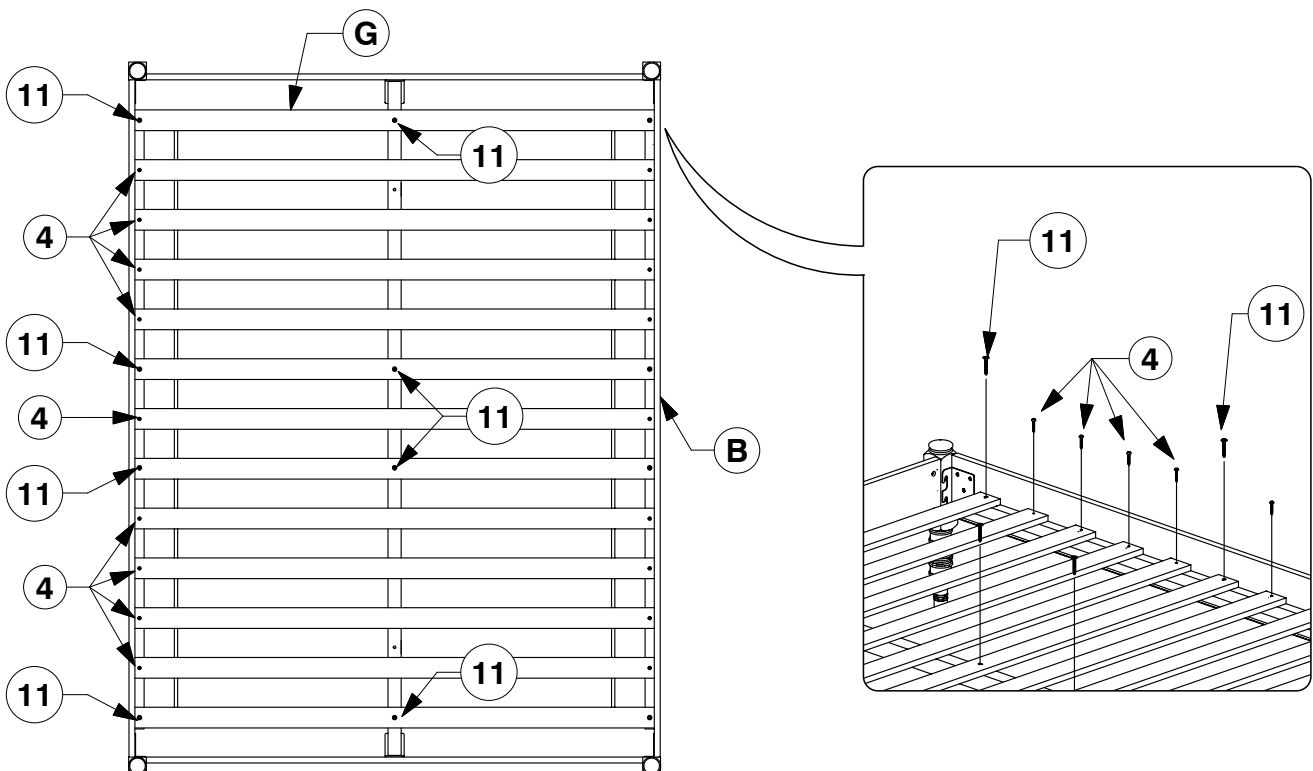

# 9765 King Headboard

Assembly Instructions

WI-0622

## 1 Parts List

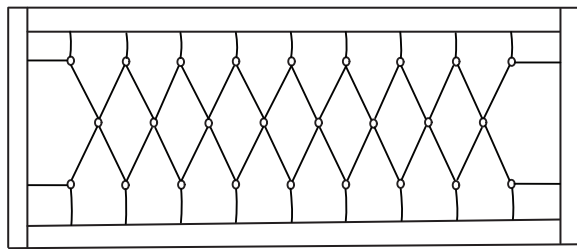

**A**  
Headboard Panel  
x 1



**B**  
Support Bars  
x 2

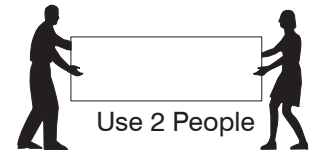

## 2 Hardware List



**1** M6 X 35mm JCB  
x 10



**2** Spring Washer  
x 10



**3** Flat Washer  
x 10



**4** Allen Key  
x 1

**Note:** Do not assemble using power tools. This can cause the bolts to be overtightened

## 3 Assemble the Support Bars (B) to the Headboard Panel.

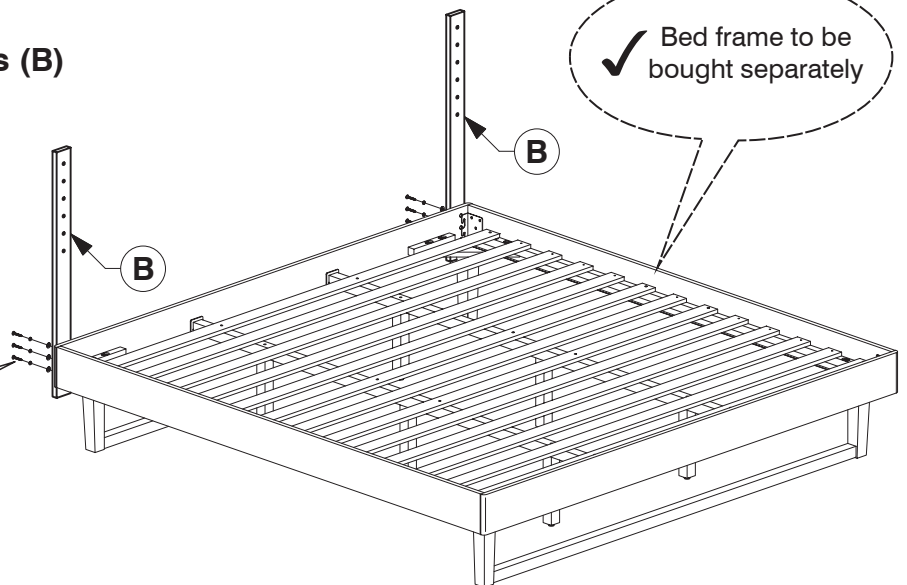
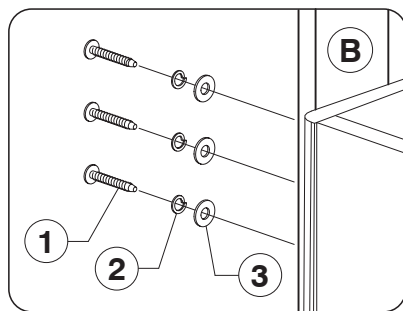

## 4 Assemble the Headboard Panel (A) to the Support Bars (B).

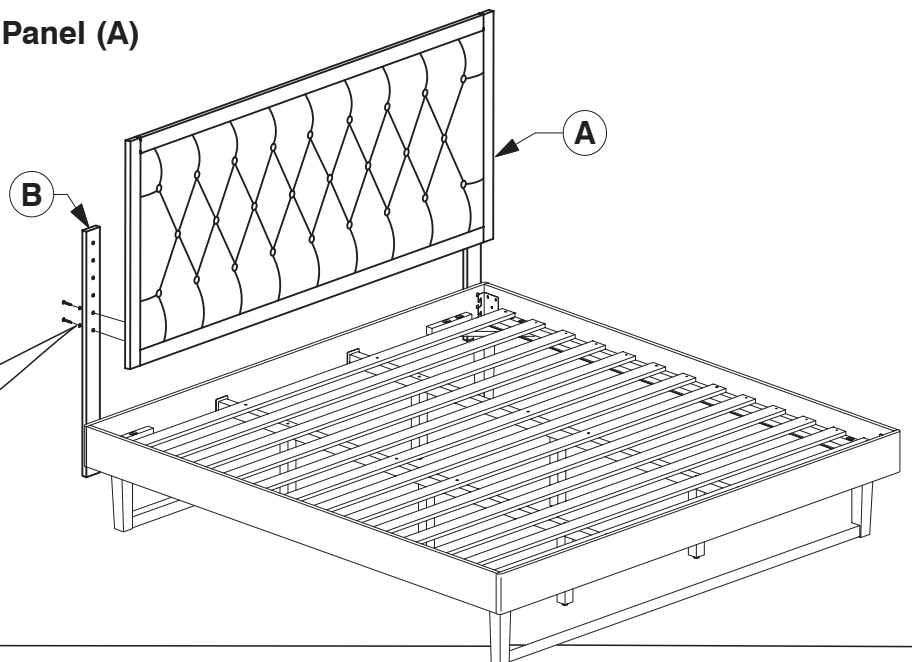
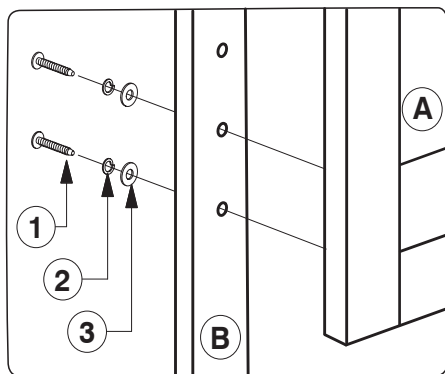

# 9766 King Headboard

Assembly Instructions

WI-0622

## 1 Parts List

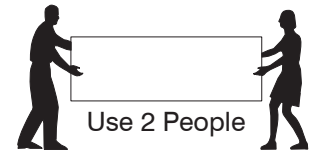
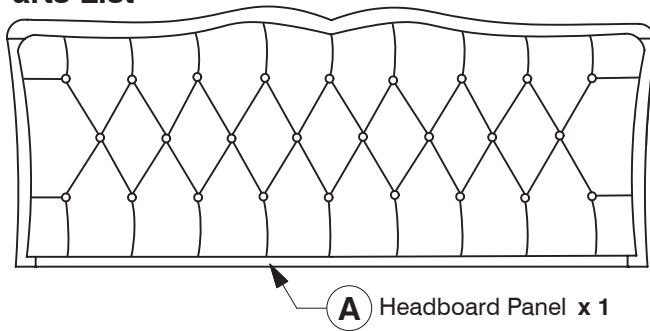

**B**  
Support Bars  
x 2



Note: Do not assemble using power tools. This can cause the bolts to be overtightened.

## 2 Hardware List



**1** M6 X 35mm JCB  
x 10



**2** Spring Washer  
x 10



**3** Flat Washer  
x 10



**4** Allen Key  
x 1

## 3 Assemble the Support Bars (B) to the Headboard Panel.

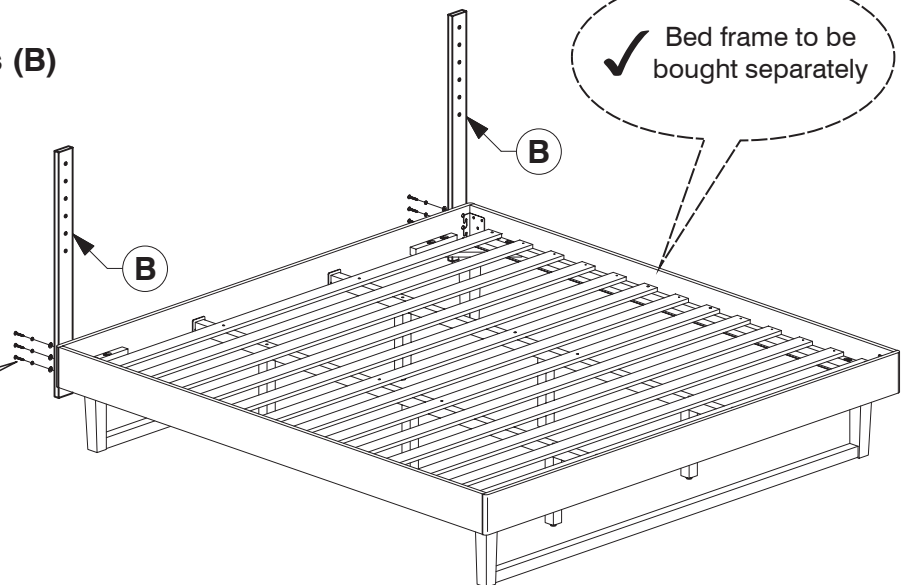
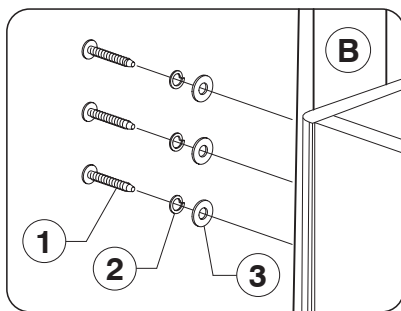

## 4 Assemble the Headboard Panel (A) to the Support Bars (B).

