

SW 8519 - Q/K

1.

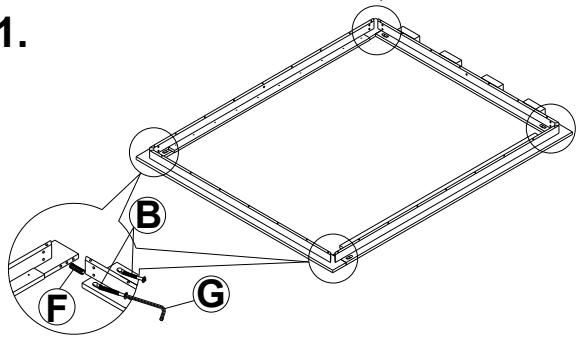

Place the headboard rail (P1), footboard rail (P2) and side rail (P5) upside down on a non-abrasive surface. Attach the headboard rail (P1) and footboard rail (P2) to the side rail (P5). You will need to use hardware:
 B = 8pcs
 F = 4pcs
 G = 1pc

WARNING!!

- Remove hardware from box and sort by size.
- Please check to see that hardware and parts are present prior start of assembly.
- Please follow attached instruction in the same sequence numbered to ensure fast and easy assembly.
- Do not use this bed if any part is broken, torn or missing.
- The assembly of this product requires two people.
- Do not use any power tools as this may damage the frame and will invalidate any claim.

2.

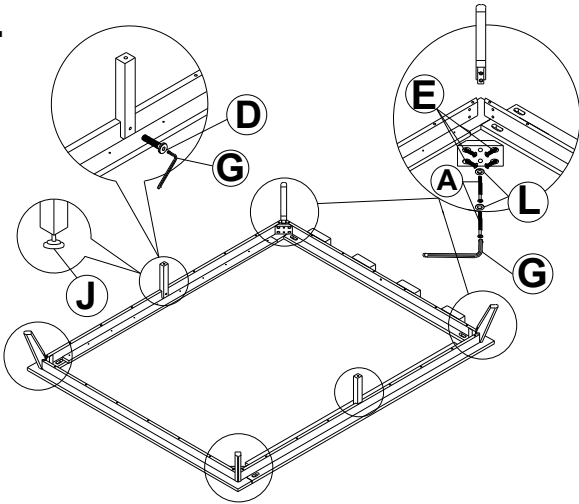

Attach the corner block (P7) to the headboard rail (P1), footboard rail (P2) and side rail (P5) and then attach the post (P8) to the corner block (P7). You will need to use hardware:
 A = 8pcs
 E = 16pcs
 G = 1pc
 L = 8pcs

Fix the adjuster (J) to the support side leg (P6) using hardware:
 J = 2pcs

Attach the support side leg (P6) to the side rail (P5) using hardware:
 D = 2pcs
 G = 1pc

PART LIST

P1		Headboard Rail	=	1pc
P2		Footboard Rail	=	1pc
P3		Headboard Panel	=	1pc
P4		Headboard Stand	=	4pcs
P5		Side Rail	=	L=1pc R=1pc
P6		Support Side Leg	=	2pcs
P7		Corner Block	=	4pcs
P8		Post	=	4pcs
P9		Center Rail	=	2pcs
P10		Bed Slats	=	14pcs
P11		Support Leg	=	4pcs

3.

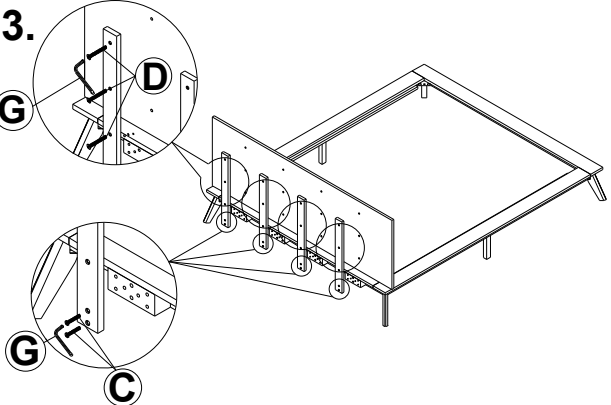

Attach the headboard stand (P4) to the headboard rail (P1) and then attach the headboard panel (P3) to the headboard stand (P4) using hardware:
 C = 8pcs
 D = 12pcs
 G = 1pc

HARDWARE LIST

A		M6 X 60MM JCBC	=	8pcs
B		M6 X 50MM JCBC	=	12pcs
C		M6 X 40MM JCBC	=	8pcs
D		M6 X 30MM JCBC	=	14pcs
E		M6 X 25MM JCBC	=	16pcs
F		M8 X 30MM WOOD DOWEL	=	4pcs
G		ALLEN KEY M4 WITH BALL	=	1pc
H		M4 X 25MM SCREW	=	8pcs
I		M3.5 X 16MM SCREW	=	16pcs
J		ADJUSTER	=	6pcs
K		L-BRACKET	=	2pcs
L		FLAT WASHER	=	8pcs

4.

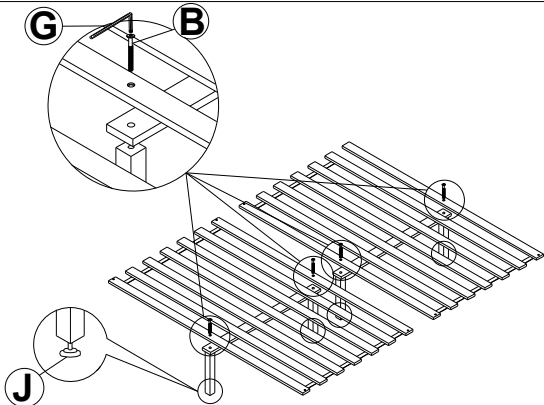

Fix the adjuster (J) to the support leg (P11) using hardware:
 J = 4pcs

Attach the support leg (P11) to the center rail (P9) and bed slats (P10) using hardware:
 B = 4pcs
 G = 1pc

5.

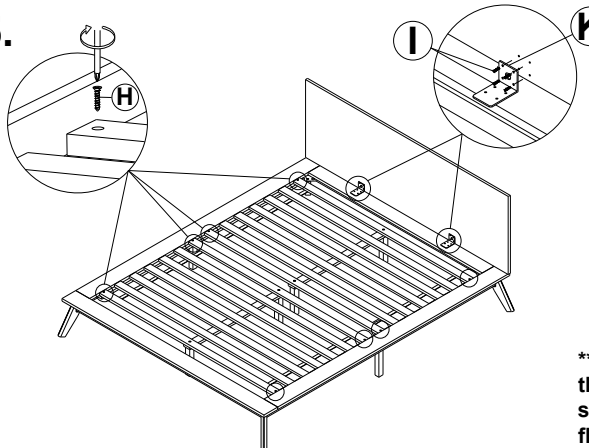

Attach the I-bracket (L) to the headboard panel (P3) and headboard rail (P1) using hardware:
 I = 16pcs
 K = 2pcs

Lastly, lay the bed slats (P10) between the side rail (P5) using hardware:
 H = 8pcs

****Apply pressure with your knee to the side rail whilst attaching the slats to ensure that the slats are flush against the inside of side rail****

