

PRODUCT CODE : CS004C DINING CHAIR





ASSEMBLY INSTRUCTIONS

Read this instruction carefully. See hardware and furniture part list for guidance. Be sure all part is complete, before you assemble. Place all wooden furniture part on a clean and flat soft surface to prevent from being scratched. Follow the figure to start assembling.

CAUTIONS :

1. Do not FULLY-TIGHTEN the nut or nut bolt until all nut or bolt is ready assembled.
2. Do not OVER-TIGHTEN the nut or nut bolt to avoid causing damages to the thread.
3. Keep all hardware part out of reach of children.

PART LIST		
ITEM	DESCRIPTION	QTY
A	BACK REST	1 PC
B	SIDE RAIL - L & R	2 PCS
C	CUSHION SEAT	1 PC
D	FRONT LEG	1 PC

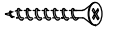
HARWARE LIST		
ITEM	DESCRIPTION	QTY
1	JCBC SCREW M6 x 50MM 	6 PCS
2	SPRING WASHER 1/4" 	6 PCS
3	NYLON WASHER - 15 x 17.5 x 6MM 	6 PCS
4	ALLEN KEY (M4) LONG 	1 PC
5	CSK SCREW M4 x 32MM 	6 PCS

Step 1 :

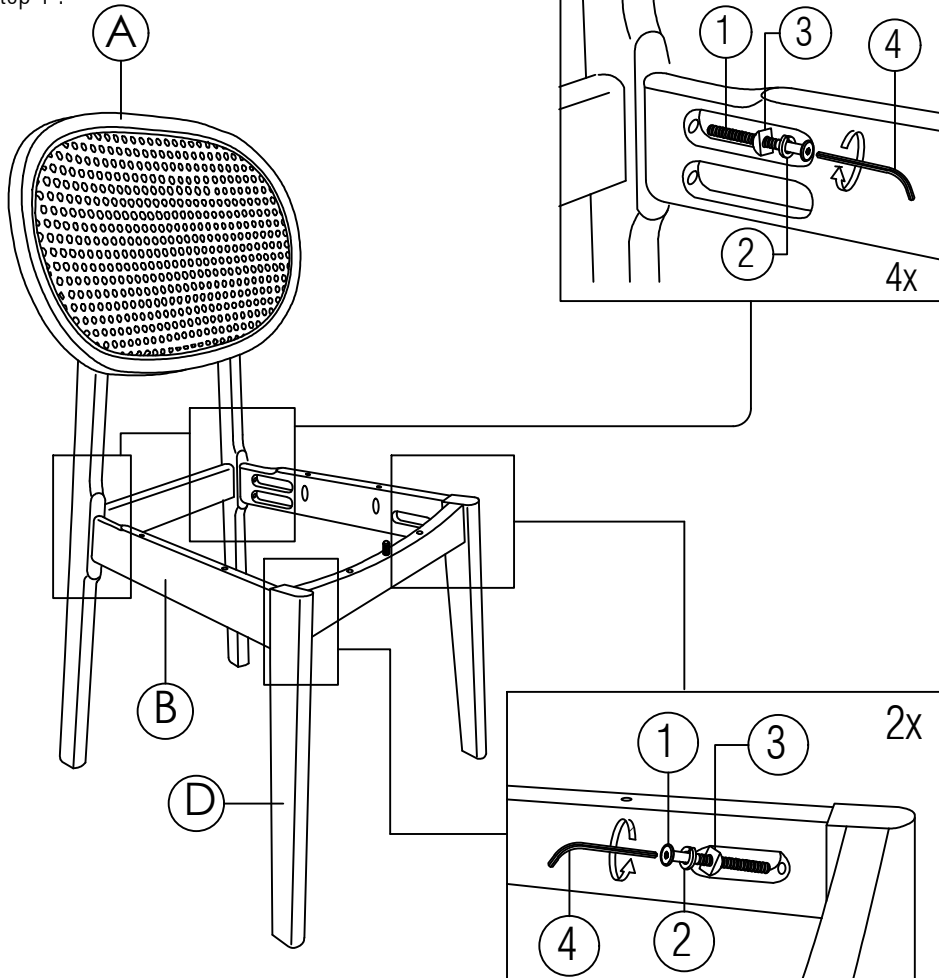

Step 2 :

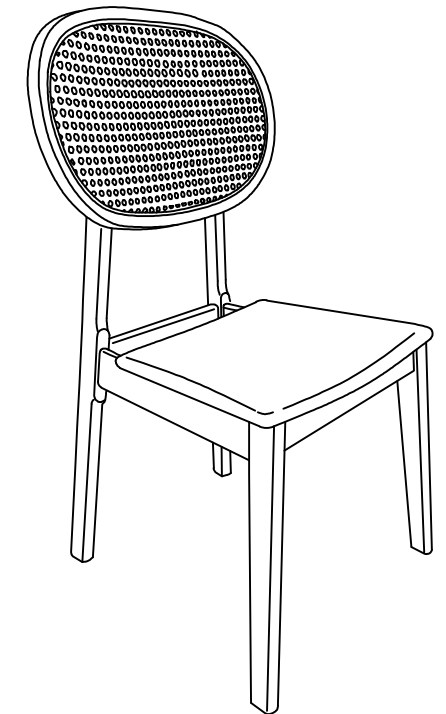
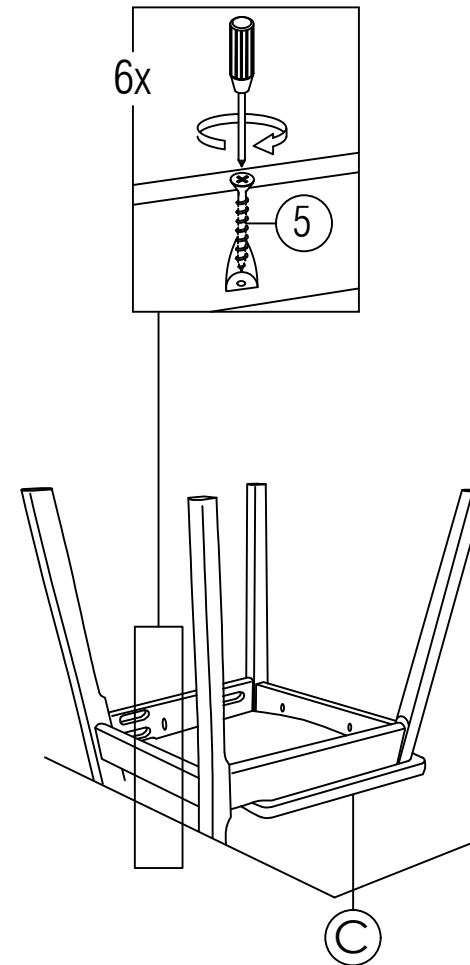

COMPLETED CHAIR ASSEMBLY

ASSEMBLY INSTRUCTION

ITEM NO : Flora Dining Table





Please read instructions carefully. Remove all wrapping material, staples and packing straps from the carton. Be sure you have all parts before you start assembling. Place all wooden furniture parts on a clean and flat soft surface, such as carpet or rug to prevent from being scratched.

CAUTION : 1) DO NOT FULLY TIGHTEN THE NUTS OR SCREWS INITIALLY UNTILL ALL THE NUTS AND
2) SCREWS ARE ASSEMBLED. TO AVOID CAUSING DAMAGE TO THE TREAD, DO NOT OVER-TIGHTEN
THE NUTS OR SCREWS.
KEEP ALL HARDWARE PARTS OUT OF RECH OF CHILDREN.

PARTS LIST

NO	DESCRIPTION	QTY
A	TABLE TOP	1
B	TABLE LEG	4

HARDWARE LIST

NO	DESCRIPTION	QTY
1	JCBB BOLT M8 x 80mm 	8
2	SPRING WASHER M8 	8
3	FLAT WASHER M8 x 22mm 	8
4	ALLEN KEY M5 x 60mm 	1

