

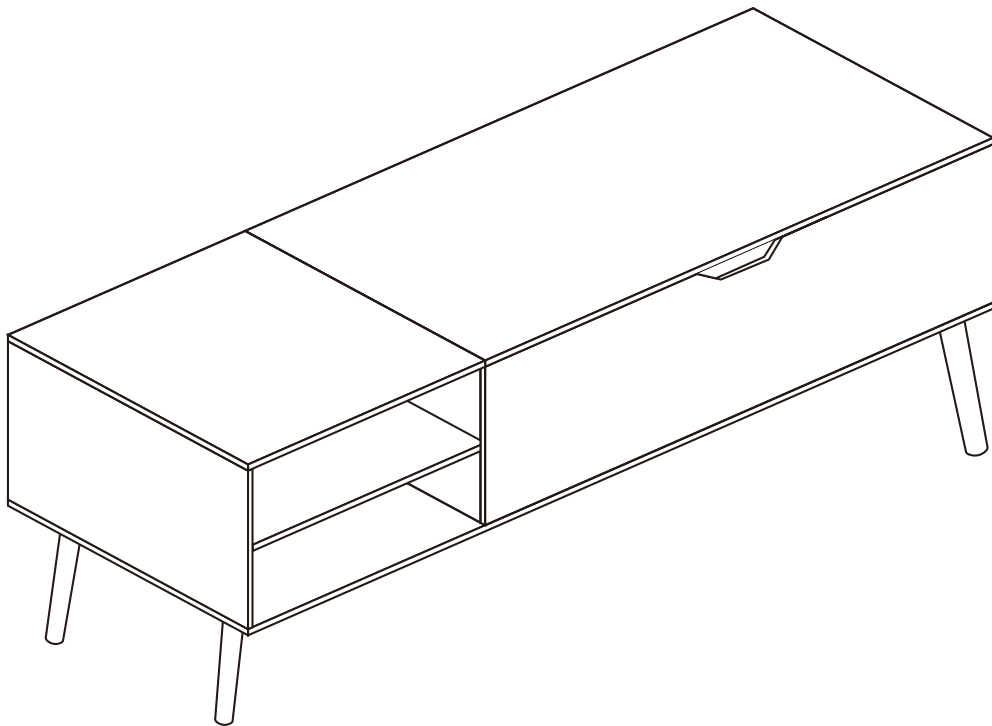









Coffee table

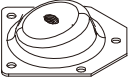

ASSEMBLY INSTRUCTION

HARDWARE LIST

A 20 PCS		B 20 PCS		C 34 PCS		D 10 PCS		E 4 PCS	
F 20 PCS		G 1 PC		H 1 PC		I 4 PCS		J 4 PCS	
K 28 PCS									

PARTS LIST

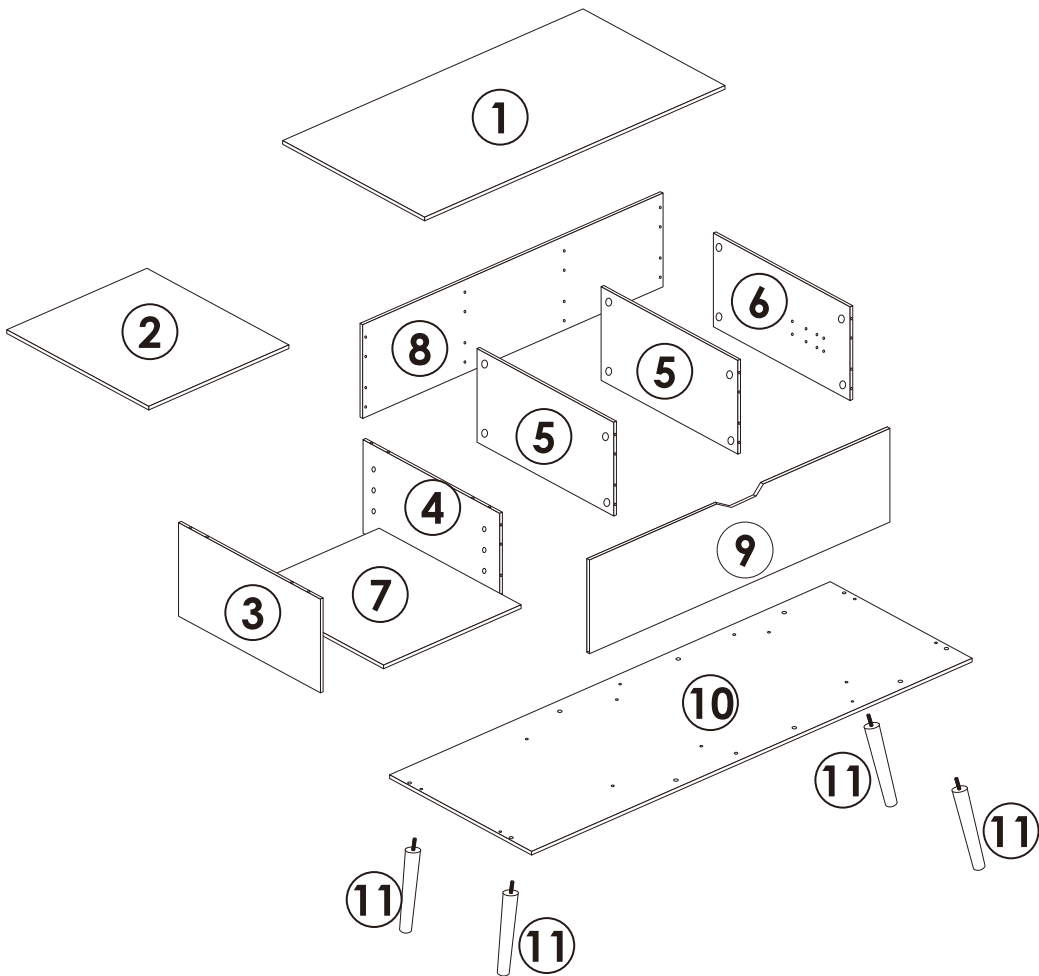

ASSEMBLY STEPS

STEP 1.

Insert quickfit screws (A) and wooden dowels (C) into part 8, as shown.
Insert cam locks (B) into parts 4, 5 and 6, as shown. Fit parts 4, 5 and 6 to part 8, as shown.
Turn cam locks clockwise to tighten.

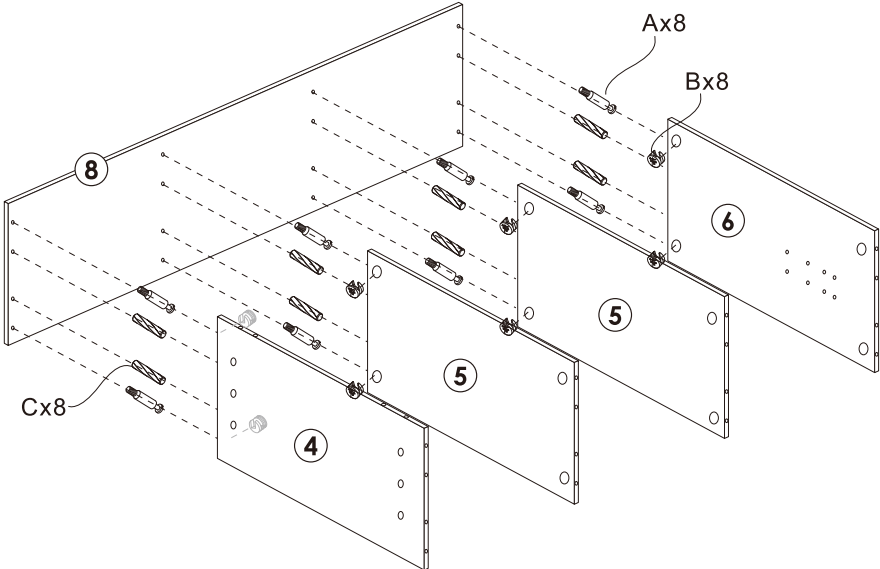

STEP 2.

Insert quickfit screws (A) into part 9, as shown.
Insert cam locks (B) and wooden dowels (C) into parts 4, 5 and 6, as shown.
Fit part 9 to parts 4, 5 and 6. Turn cam locks clockwise to tighten.

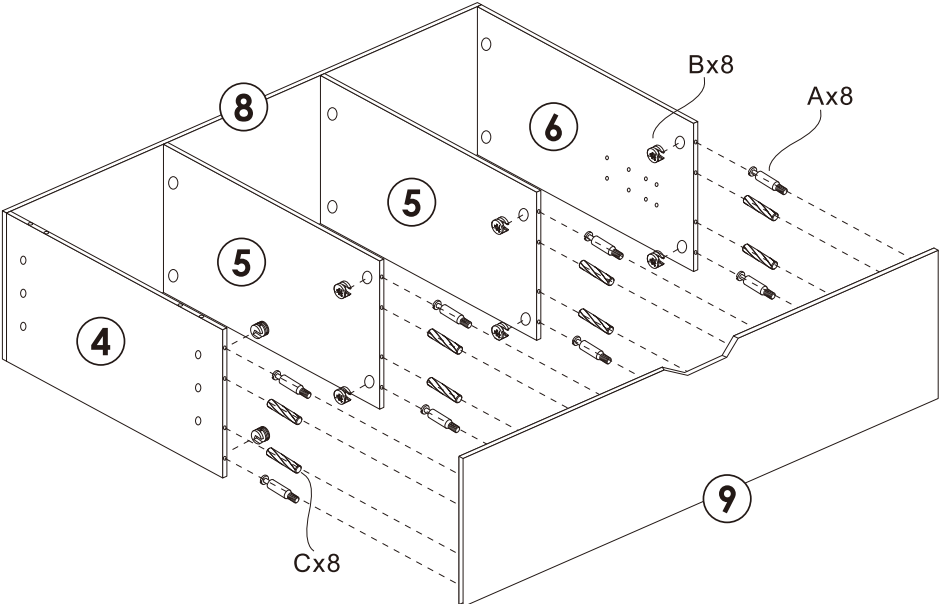

ASSEMBLY STEPS

STEP 3.

Fix part 3 to part 10 with wooden dowels (C) and screws (D), as shown.

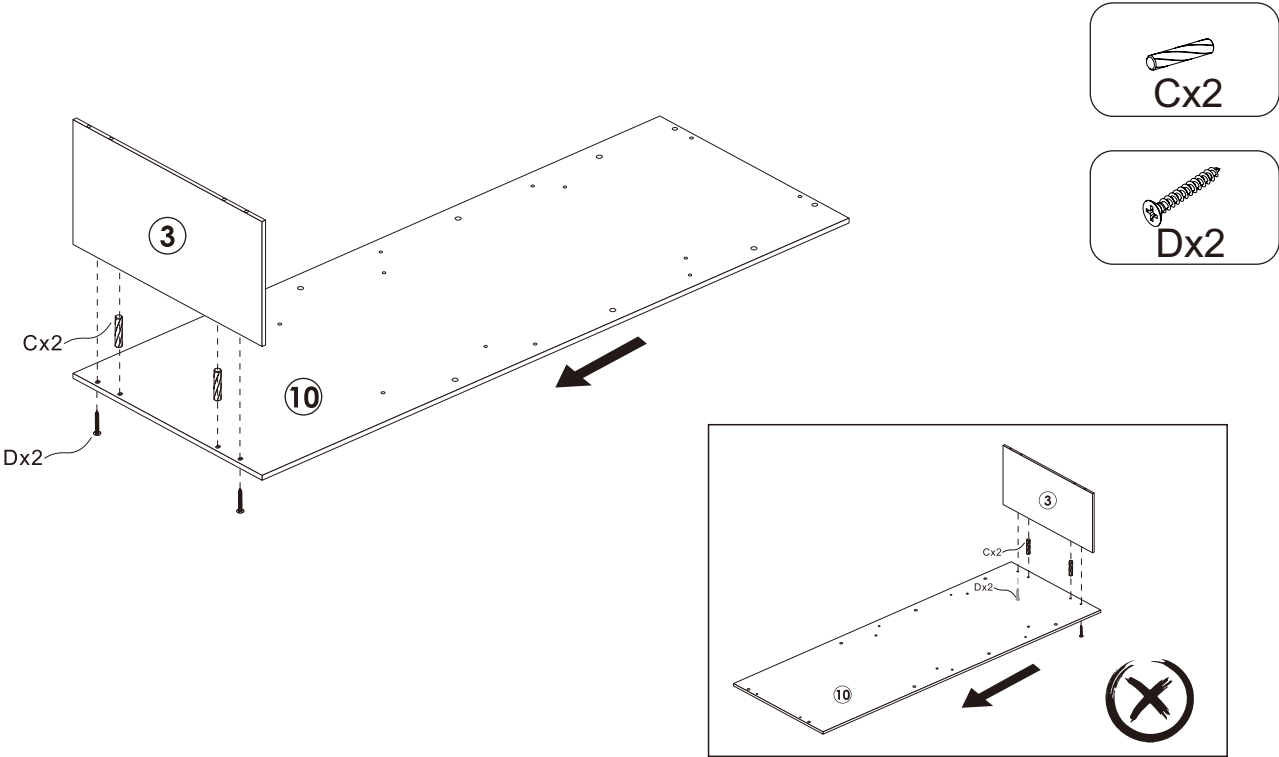

STEP 4.

Insert wooden dowels (C) into parts 4, 5, 6, 8 and 9, as shown.
Fit part 10 to parts 4, 5, 6, 8 and 9 and fix with screws (D), as shown.

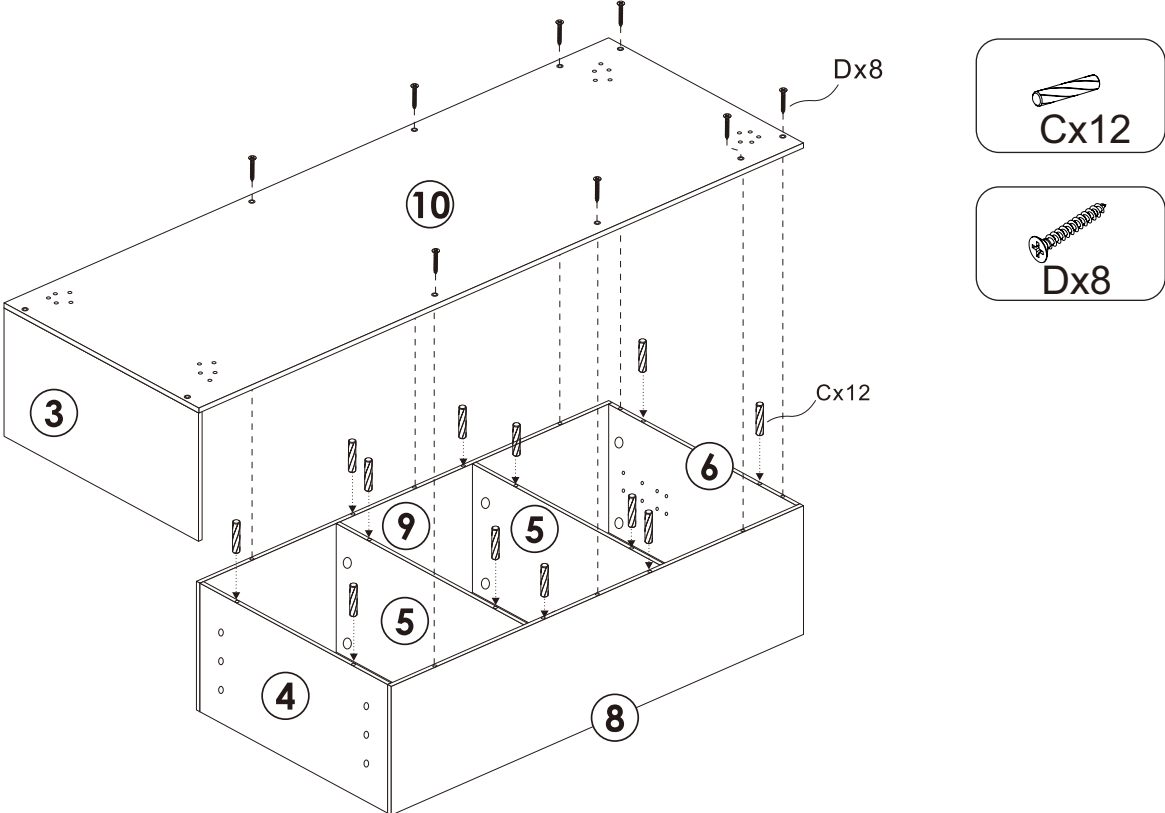

ASSEMBLY STEPS

STEP 5.

Fix parts (E) to part 10 using screws (F), as shown.

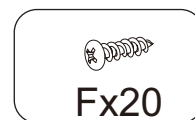
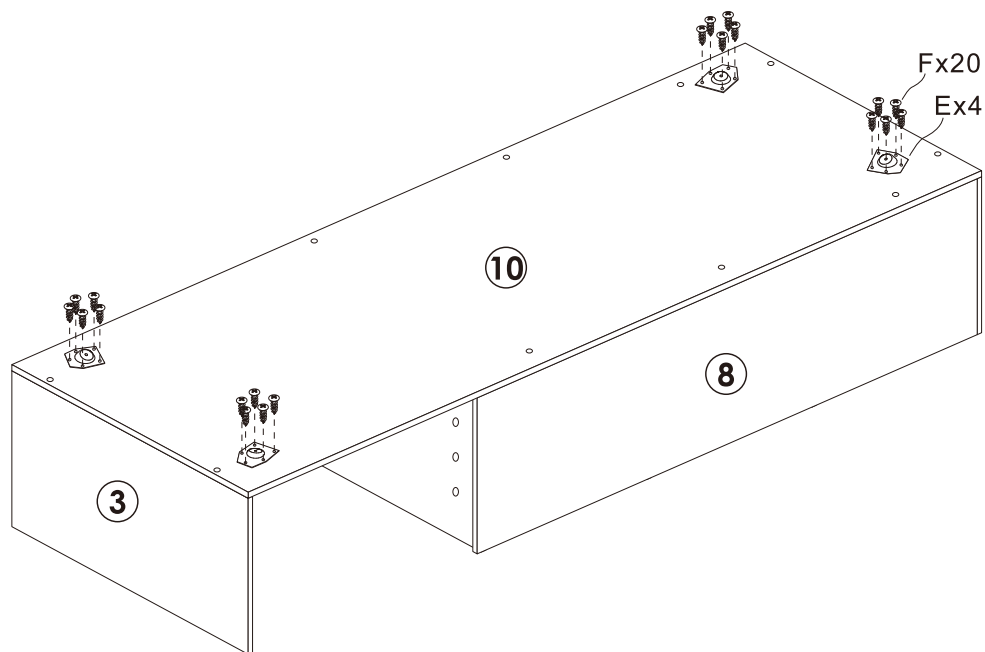

STEP 6.

Fix legs 11 to part 10, as shown. Turn clockwise to tighten. Attach pads (I) to legs 11, as shown.

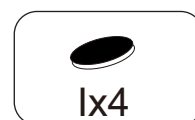
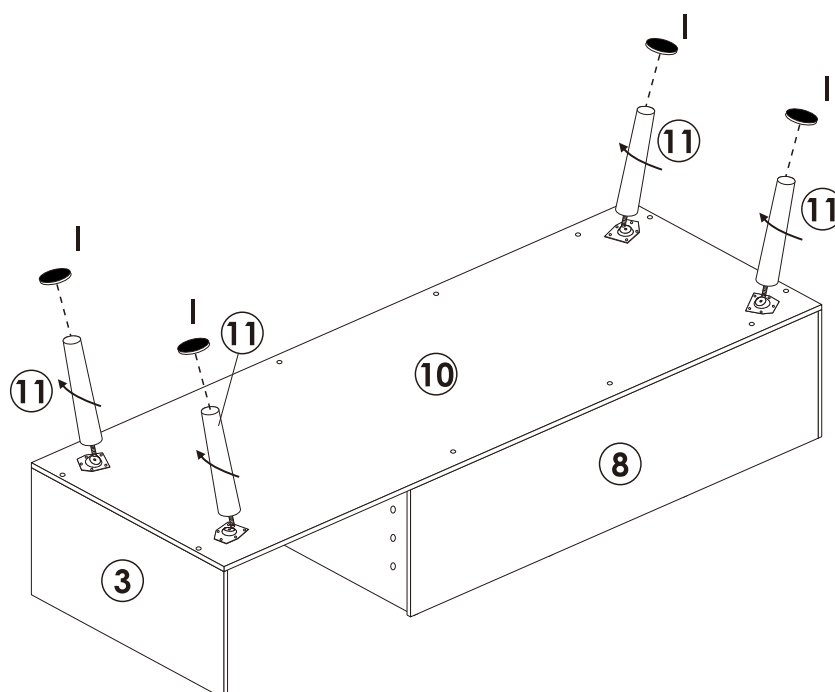

ASSEMBLY STEPS

STEP 7.

Insert quickfit screws (A) into part 2, as shown.
Insert cam locks (B) and wooden dowels (C) into parts 3 and 4, as shown.
Fit part 2 to parts 3 and 4. Turn cam locks clockwise to tighten.

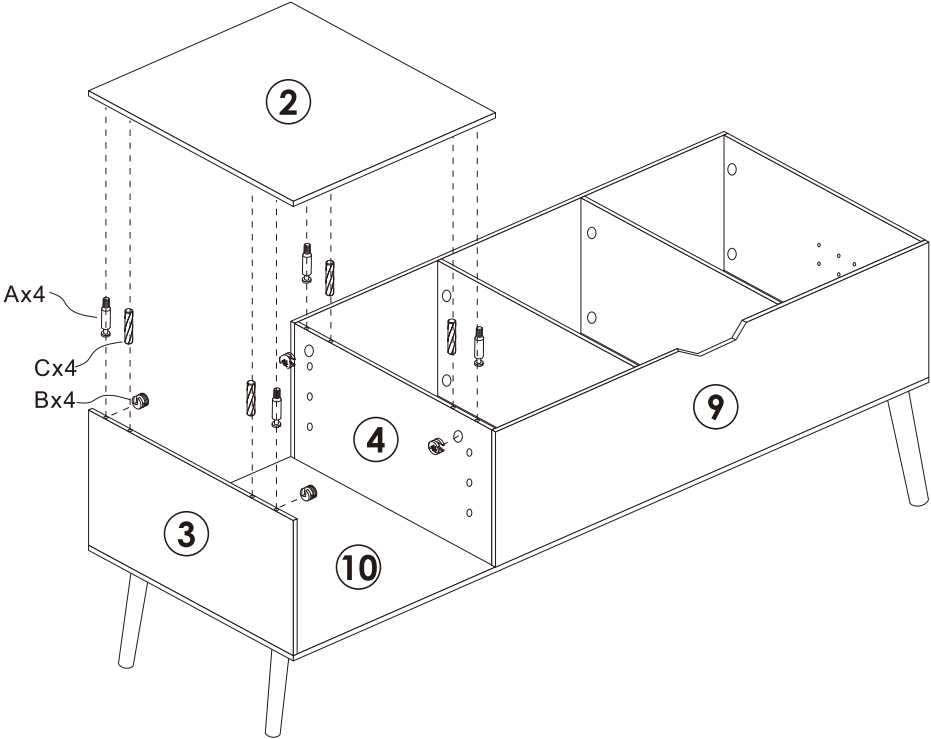

STEP 8.

Fix lifting rods (H) and (G) to part 1 using screws (K), as shown.

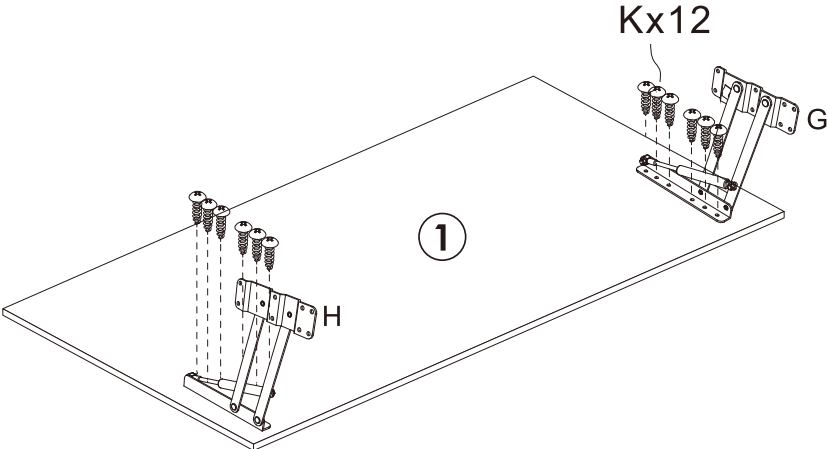

ASSEMBLY STEPS

STEP 9.

Fix part 1 to assembled unit with lifting rods and screws (K), as shown.

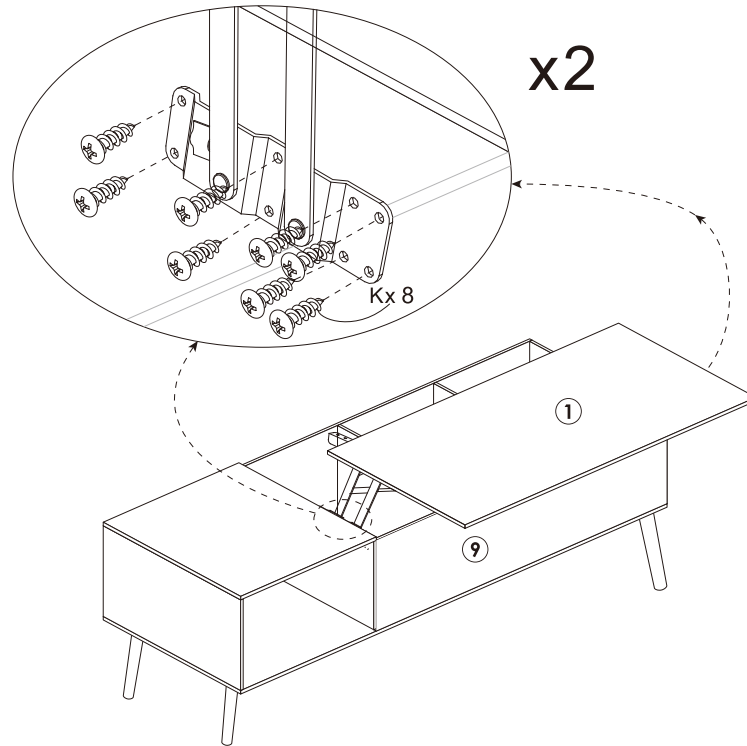
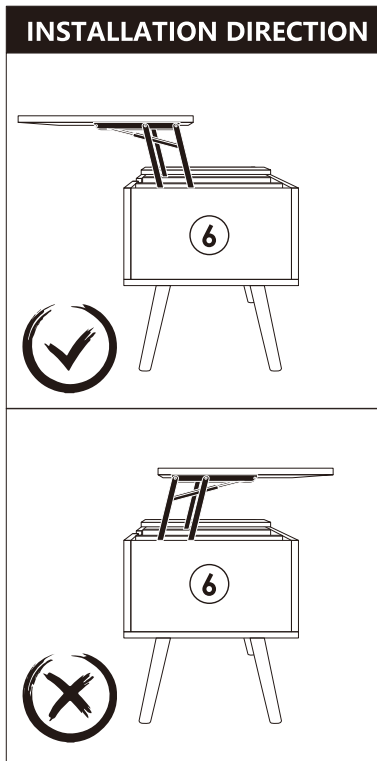
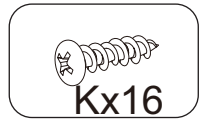

STEP 10.

Fit shelf supporters (J) to the inside of coffee table, as shown.
Place shelf 7 on top of shelf supporters, as shown.

