

0038 Queen Bed

Assembly Instructions

W11-0120

1 Assembled View

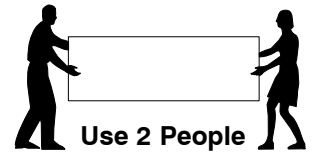
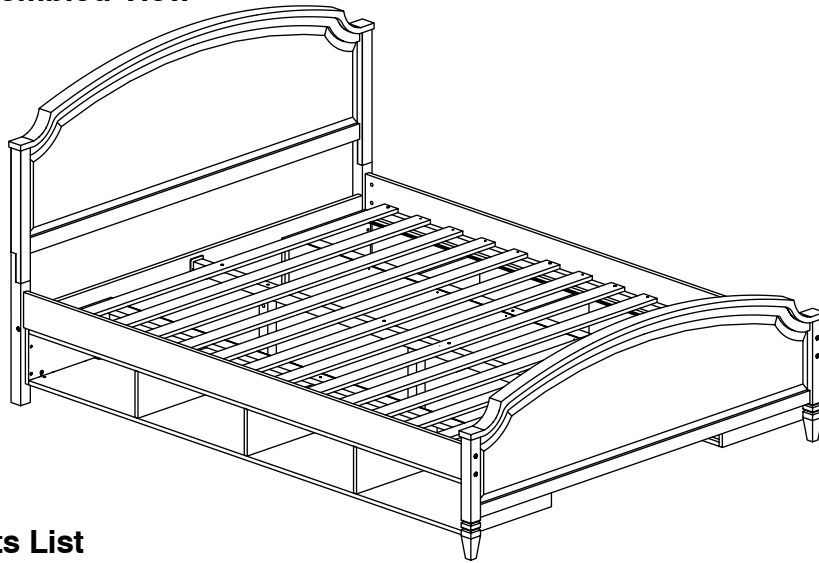

Note: Do not assemble using power tools. This can cause the bolts to be overtightened

2 Parts List

Parts in Box A:

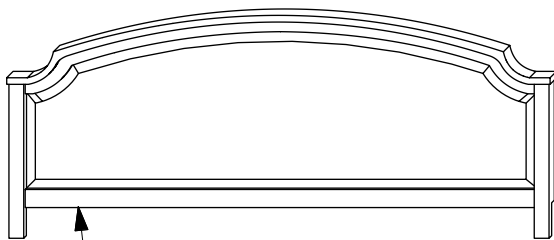

A Headboard Panel x 1

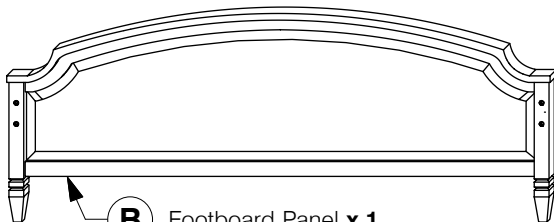

B Footboard Panel x 1

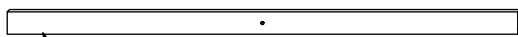

C Headboard Support Rail x 1

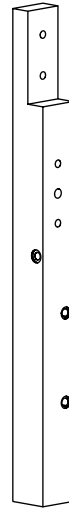

D Headboard Post (Left Hand) x 1

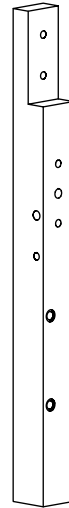

E Headboard Post (Right Hand) x 1

Parts in Box B:



F Side Rail x 2

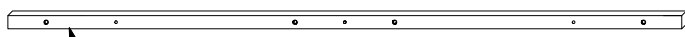

G Long Support x 1



H Support Leg x 3

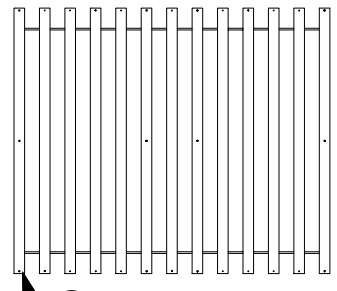

J Set of Bed Slats x 1

0038 Queen Bed

Assembly Instructions

WII-0120

2 Parts List

Parts in Box C:

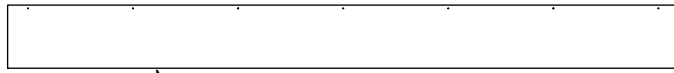

K Storage Back Panel x 2

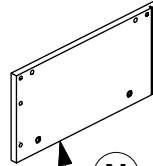

N
Storage Side Panel
(Left Hand)
x 2

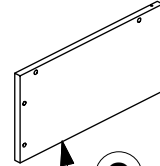

O
Storage Side Panel
(Right Hand)
x 2

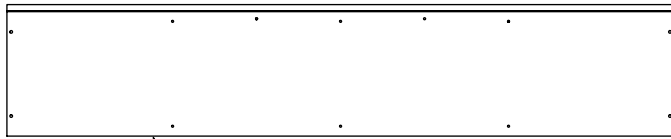

L Storage Bottom Panel x 2

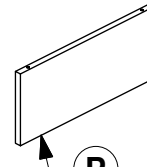

P
Storage Divider
x 6



Q
Storage Foot
x 4

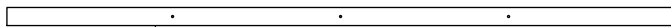

M Storage Support Rail x 4

3 Hardware List



1 M4 Allen Key
x 1

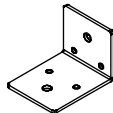

2 Center Rail
Bracket x 2



3 'L' Bracket
x 8

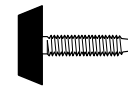

4 Adjustable
Foot x 3



5 Barrel
Nut x 13



6 Wood Screw
(M4 x 16mm)
x 14

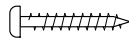

7 Wood Screw
(M4 x 32mm)
x 18



8 Wood Dowel
(M8 x 30mm)
x 8



9 Wood Dowel
(M10 x 40mm)
x 6



10 Spring
Washer
x 4



11 Flat
Washer
x 4

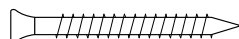

12 CSK Cap Wood Screw
(M6 x 50mm)
x 24



13 M6 x 15mm
JCB x 20

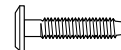

14 M6 x 30mm
JCB x 8



15 M6 x 40mm
JCB x 20



16 M6 x 60mm JCB
x 8



17 M6 x 90mm JCB
x 13

0038 Queen Bed

Assembly Instructions

WII-0120

- 4** Fit the Lower Headboard Post (D & E) to the Headboard Support Rail (C).

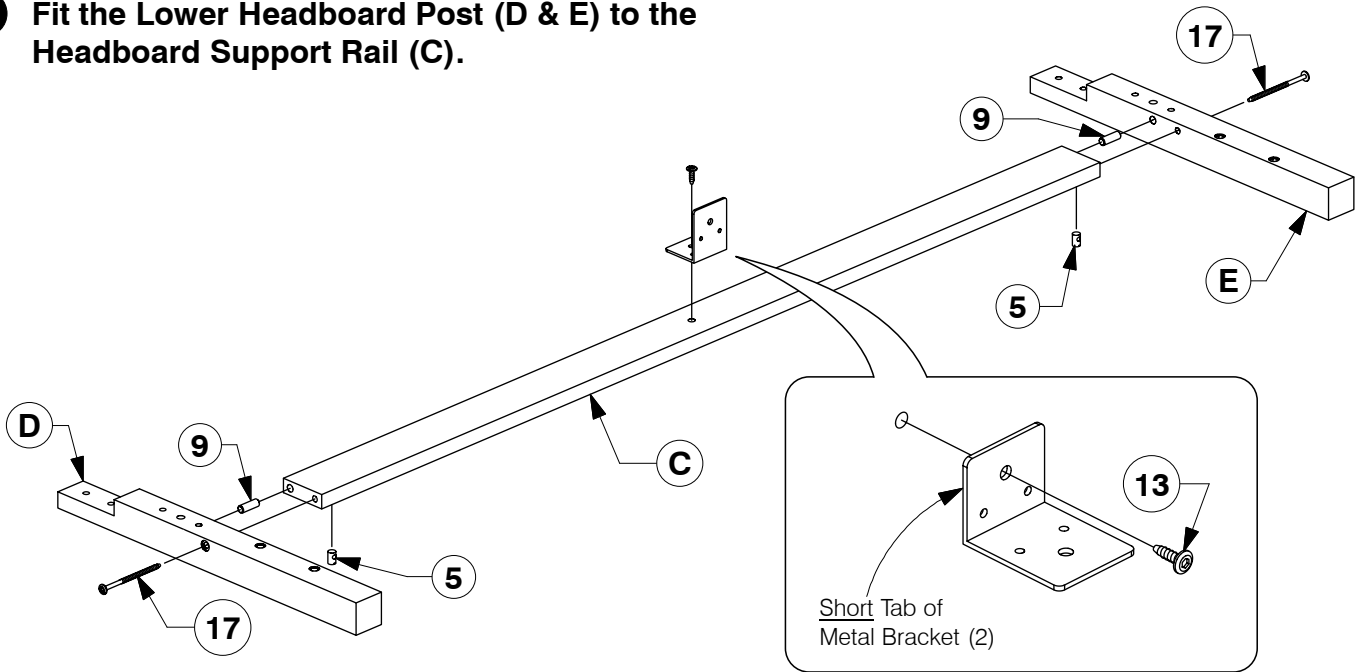

- 5** Fit the Headboard Panel (A) to the Headboard Post (D & E).

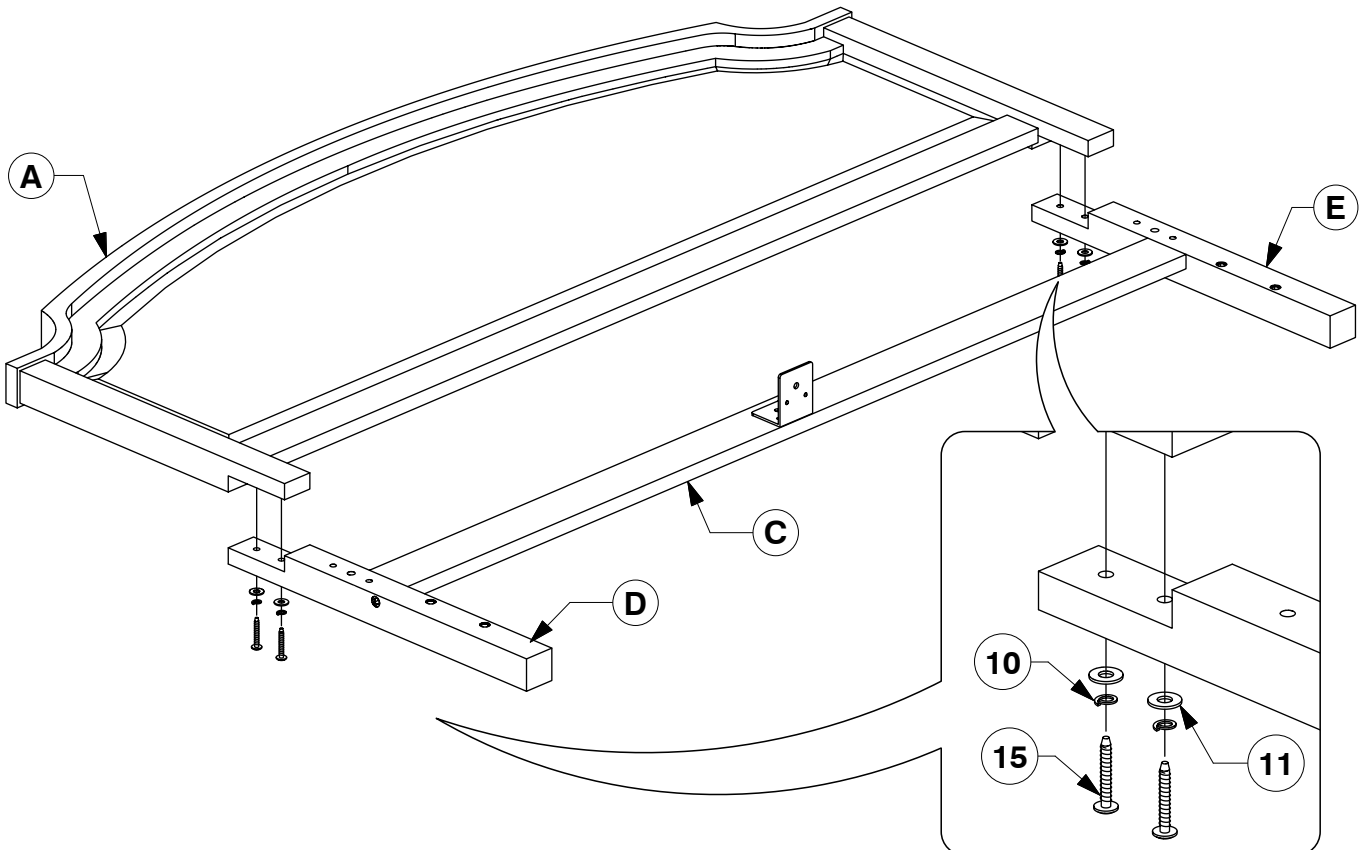

0038 Queen Bed

Assembly Instructions

WII-0120

- 6** Fit the Center Rail Bracket to the Footboard Panel (B).

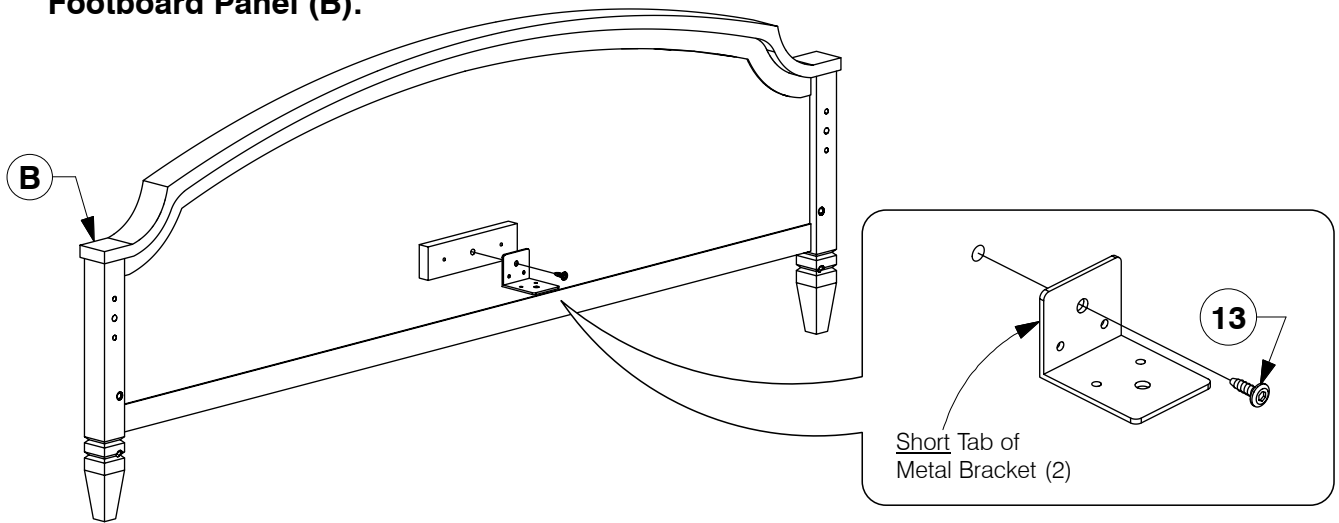

- 7** Assemble the Support Leg (H) to the Long Support (G).

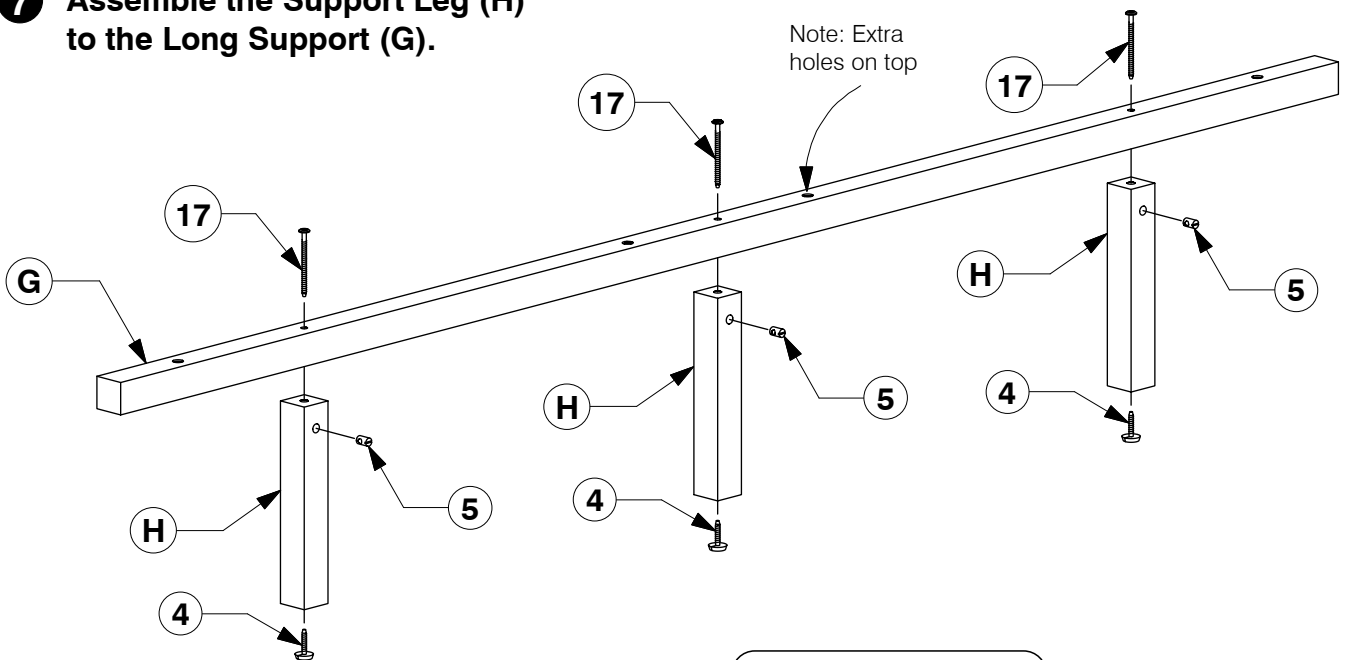

- 8** Fit the 'L' Bracket (3) to the End of the Storage Bottom Panel (L) with M6 x 15mm JCB (13).

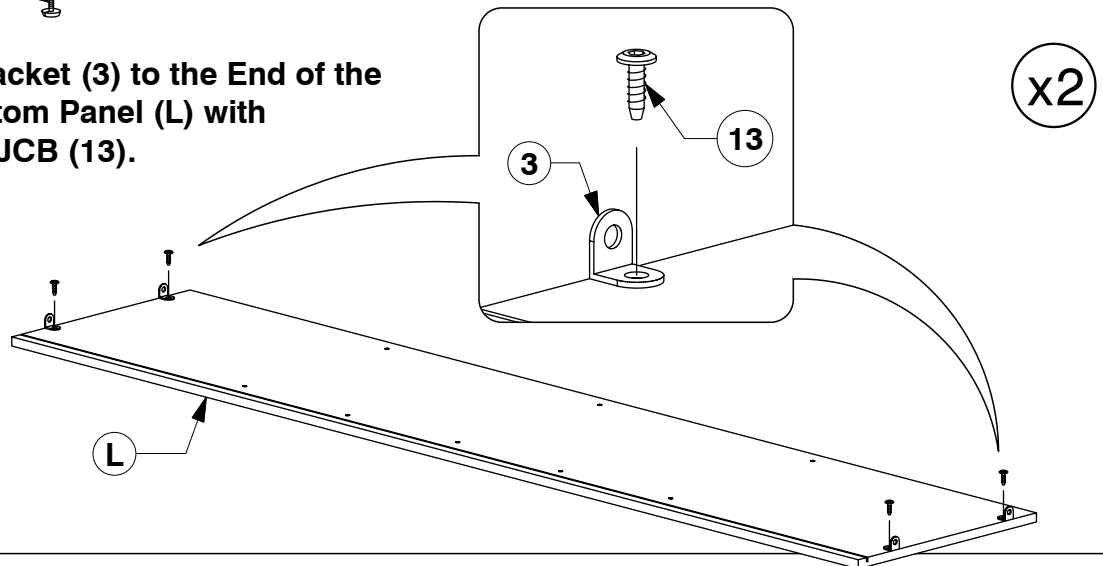

0038 Queen Bed

Assembly Instructions

WII-0120

- 9** Tap the Wood Dowel to the end of the Storage Support Rail (M).

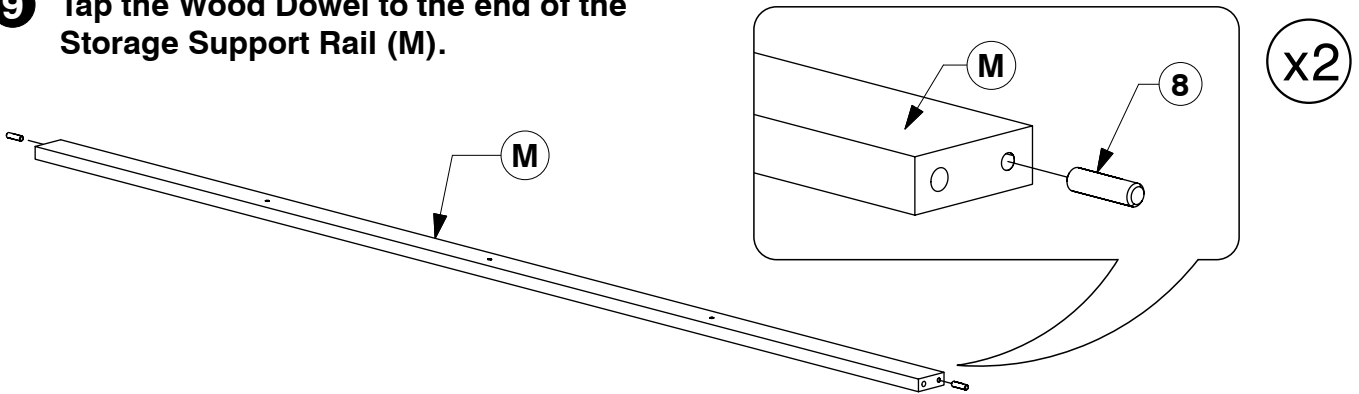

- 10** Assemble the Storage Bottom Panel (L) & Support Rail (M) to the Storage Divider (P).

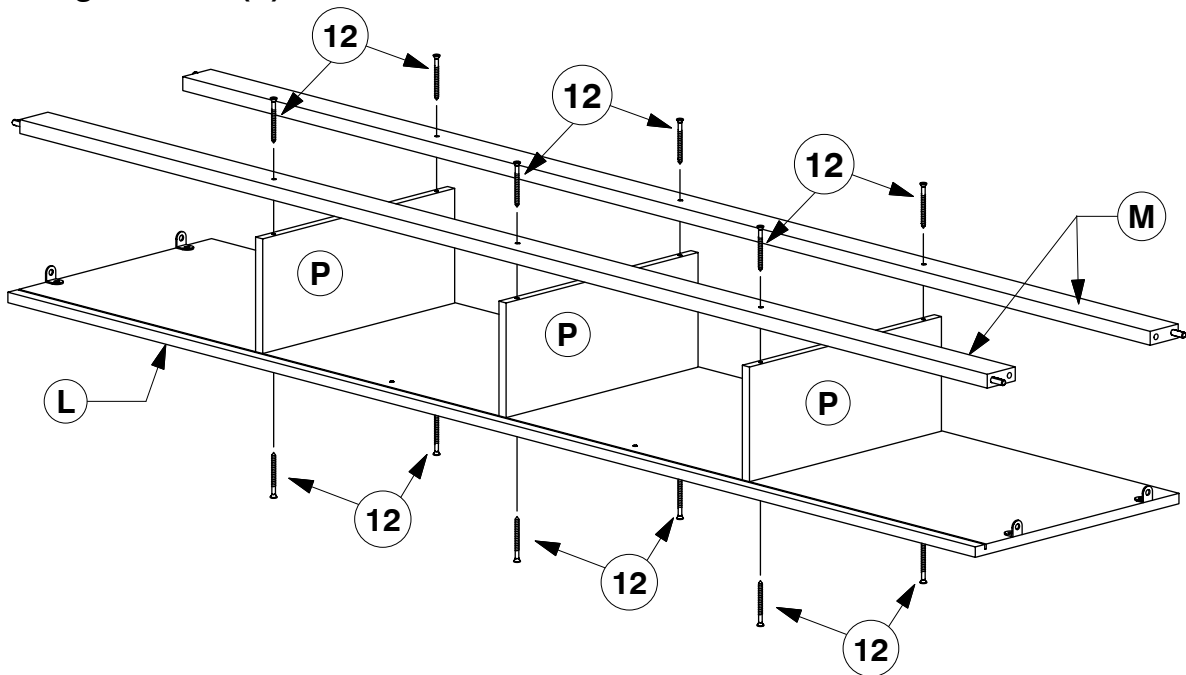

- 11** Assemble the Storage Side Panel (N & O) to the Storage Bottom Panel & Support Rail (L & M).

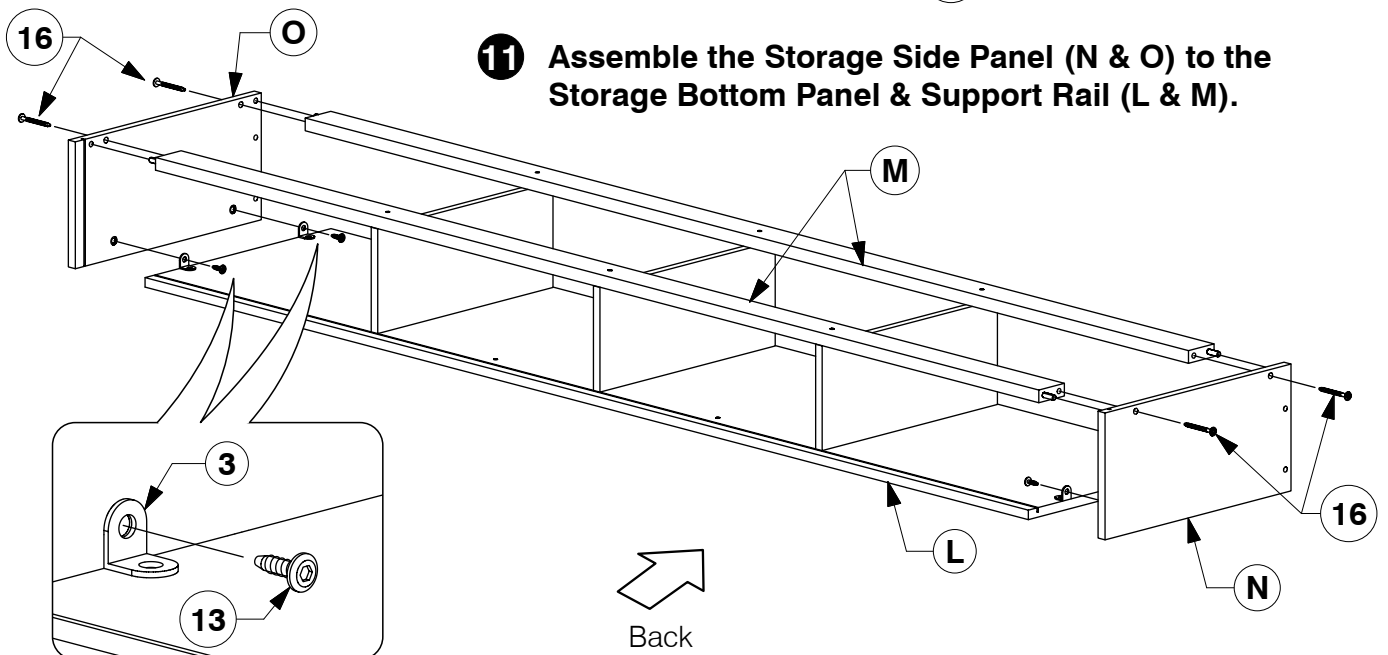

0038 Queen Bed

Assembly Instructions

WII-0120

12 Fit the Storage Foot (Q) to the Storage Bottom Panel (L).

x2

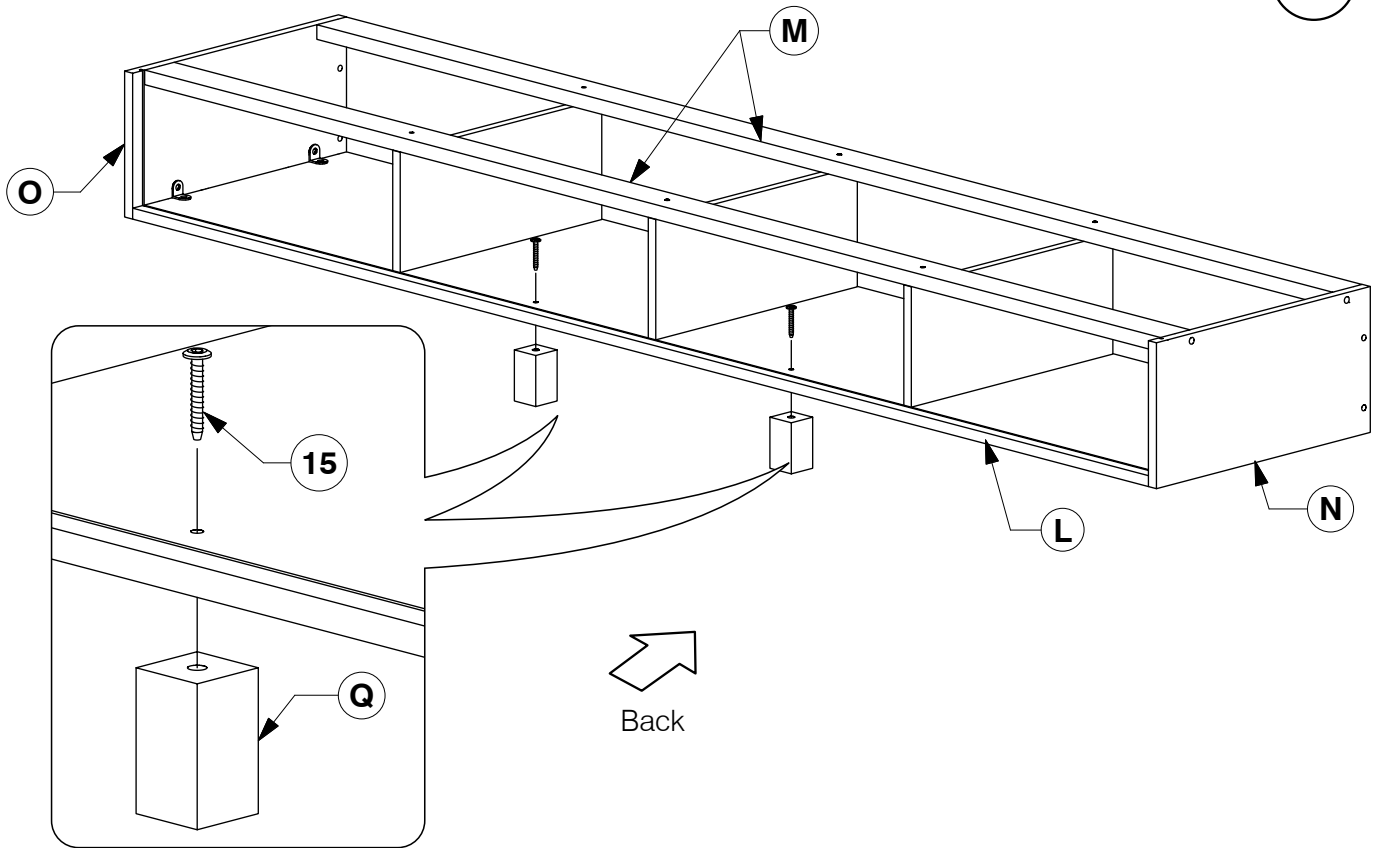

13 Slide the Storage Back Panel (K) into the groove.

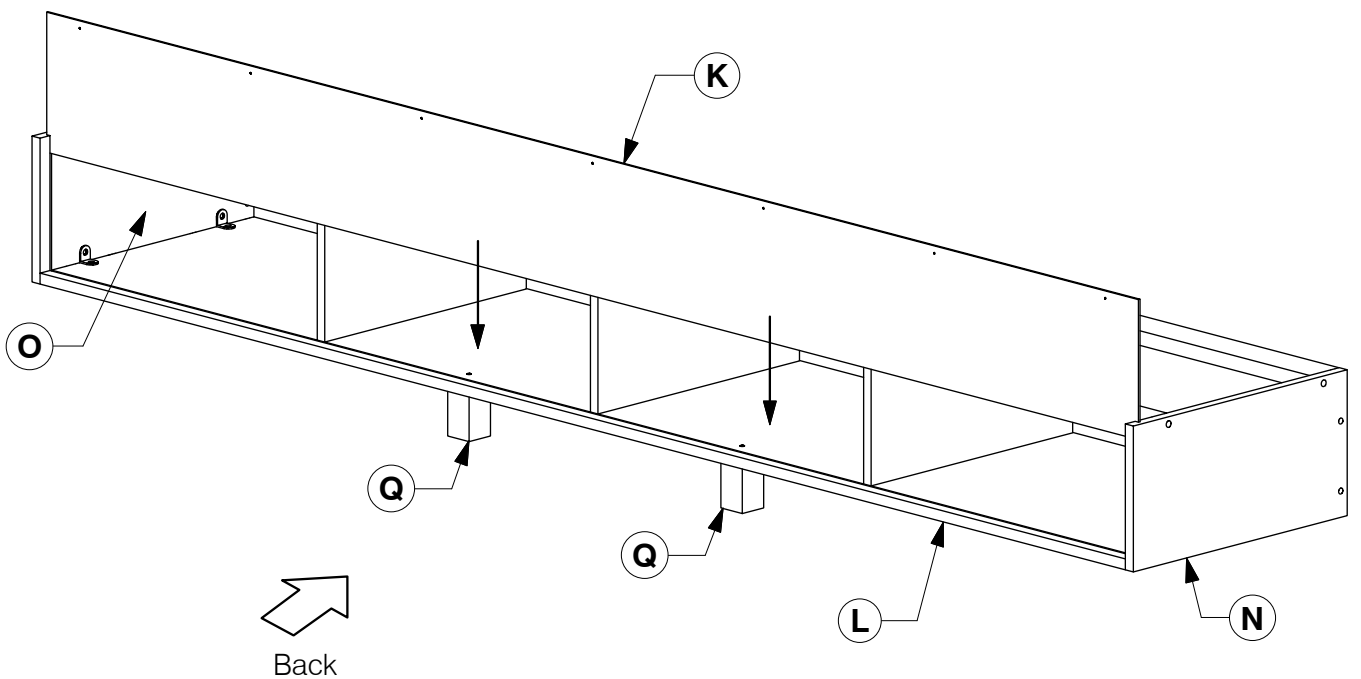

0038 Queen Bed

Assembly Instructions

WII-0120

- 14** Fit the Storage Back Panel (K) in place.

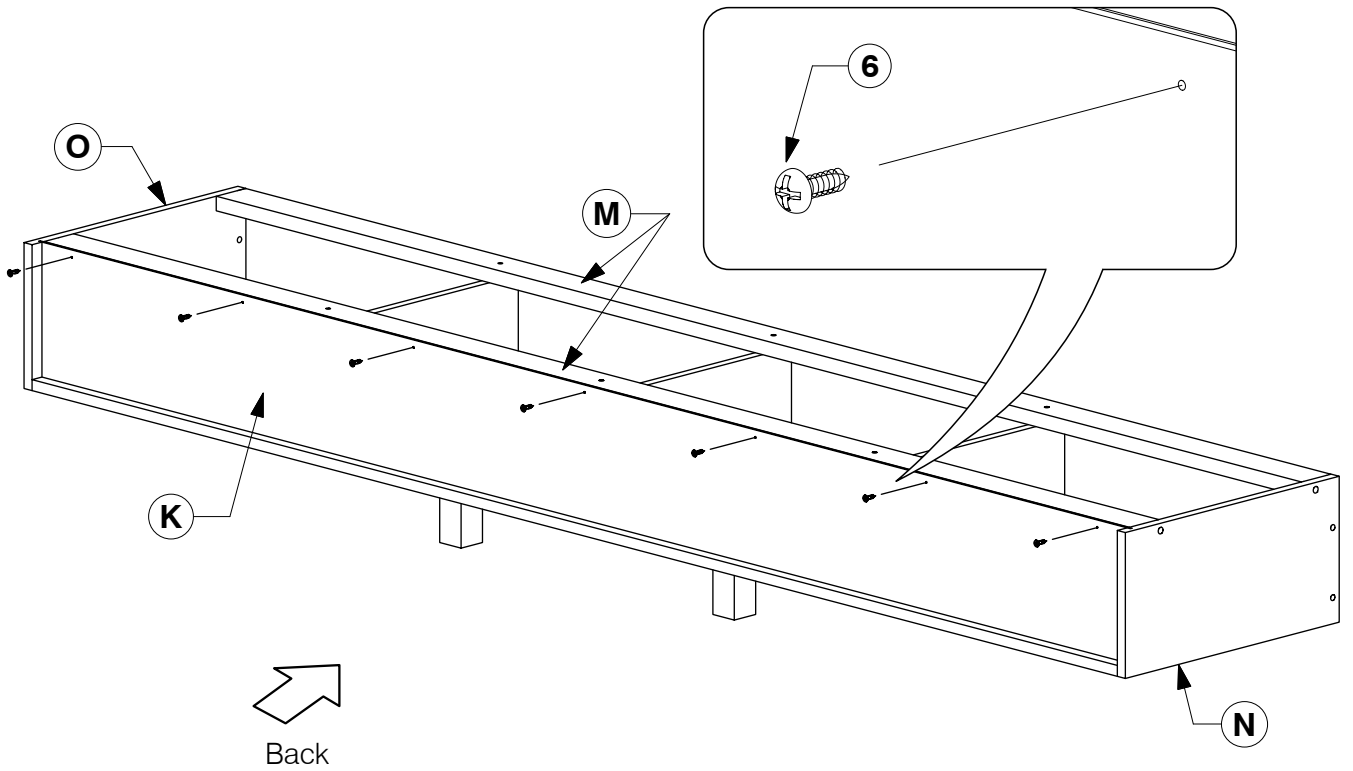

- 15** Assemble the Side Rail (F) to the Headboard / Footboard (A & B).

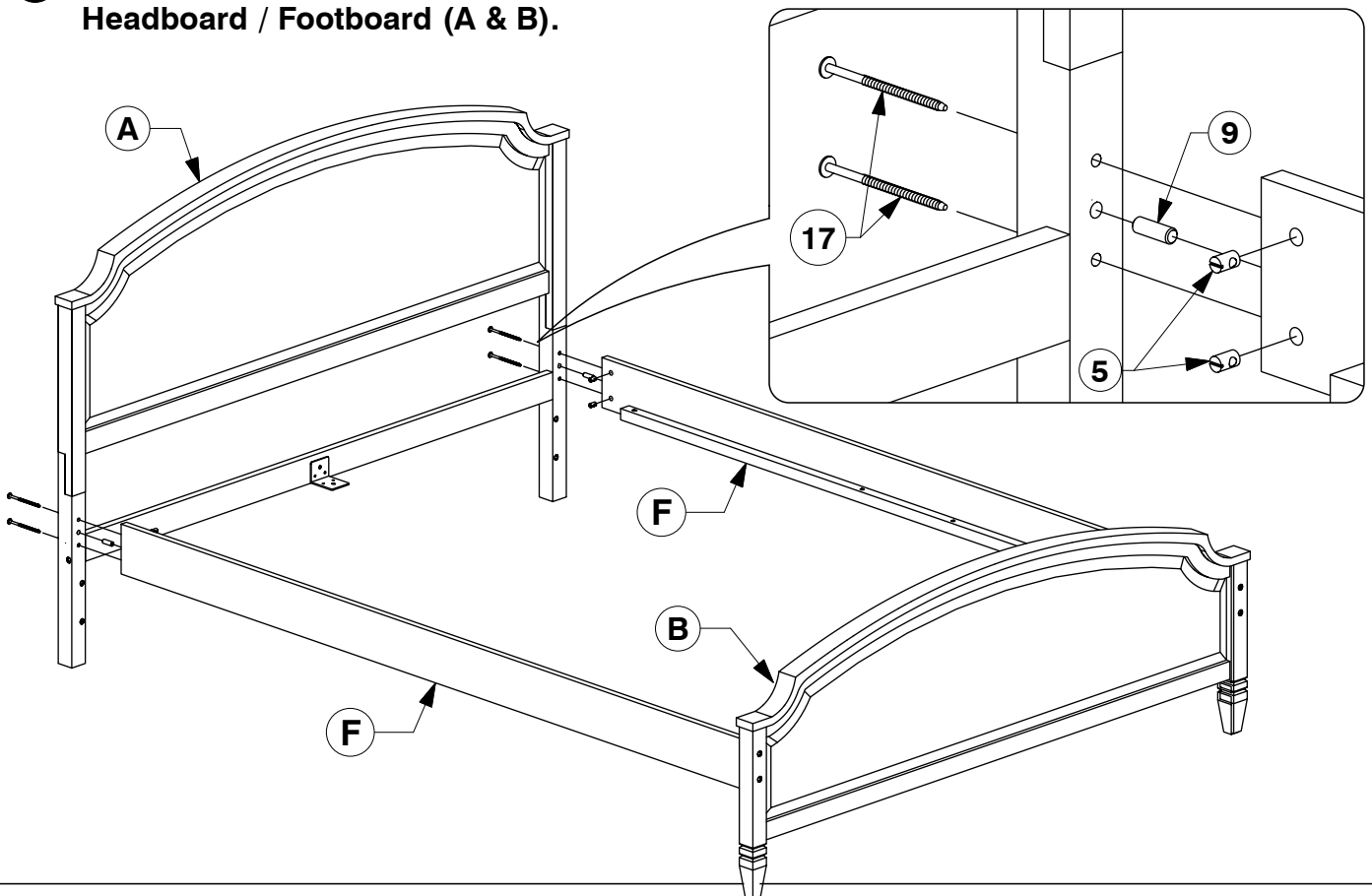

0038 Queen Bed

Assembly Instructions

WII-0120

- 16** Bolt the Long Support (G) to the Center Rail Brackets on the Headboard Panel / Footboard Panel (A & B).

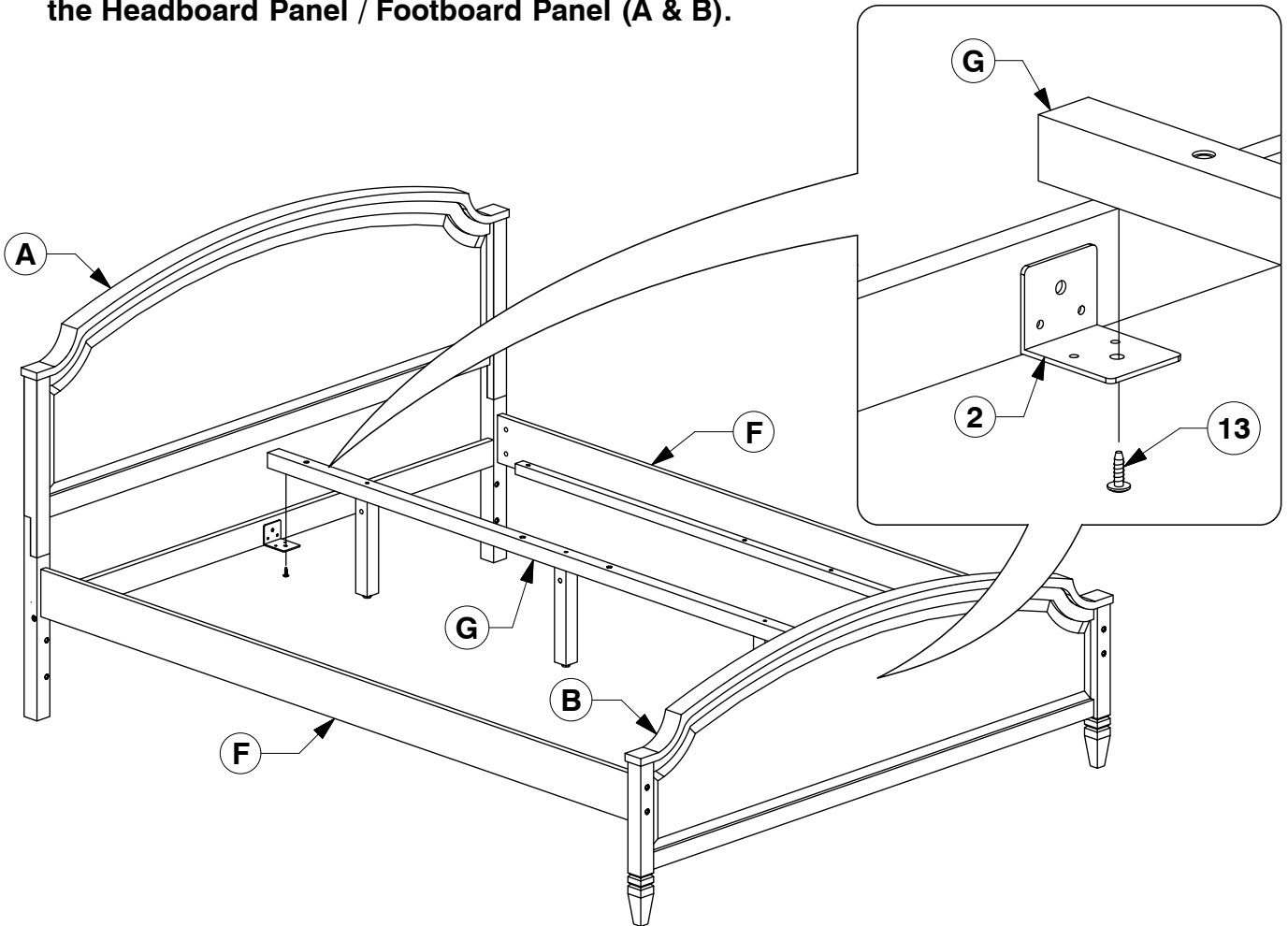

- 17** Bolt & screw the Bed Slats (J) to the Side Rail (F).

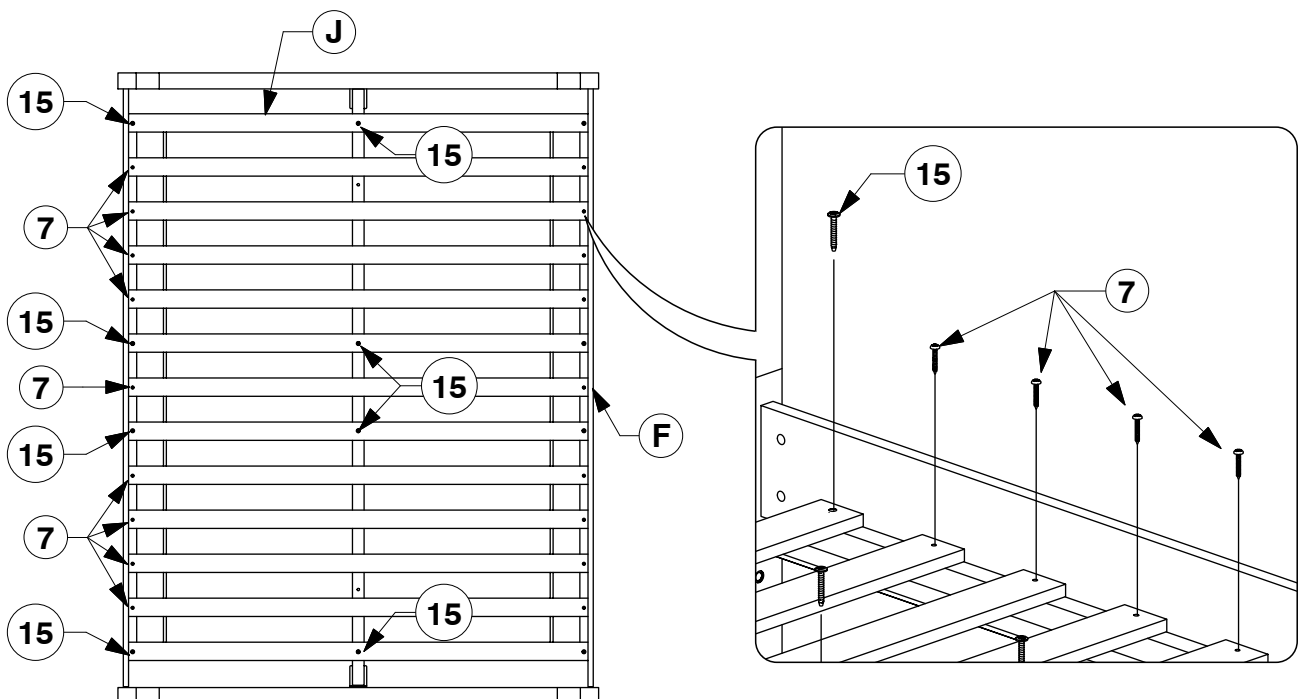

0038 Queen Bed

Assembly Instructions

W11-0120

- 18** Fit the Assembled Storage under the Bed Frame.

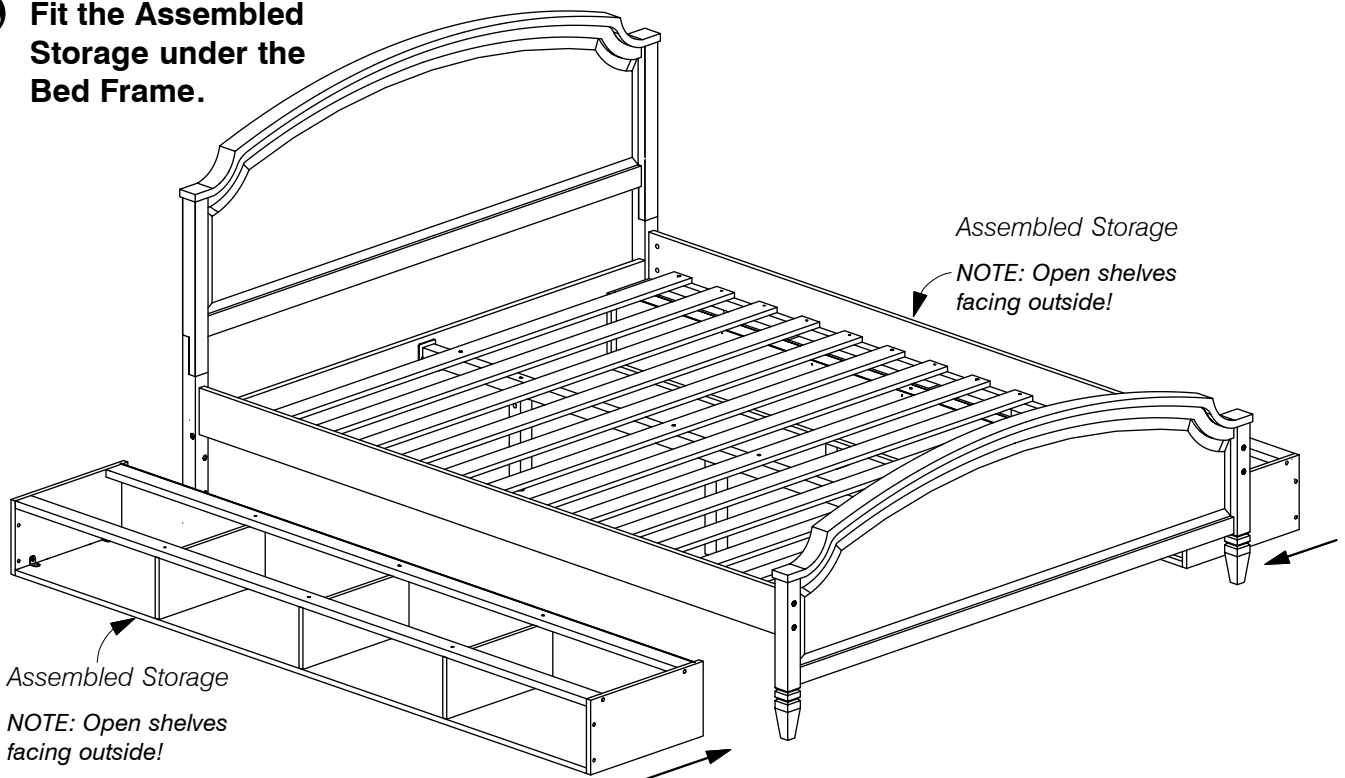

- 19** Bolt the Assembled Storage to the Bed Frame with M6 x 30mm JCB (14).

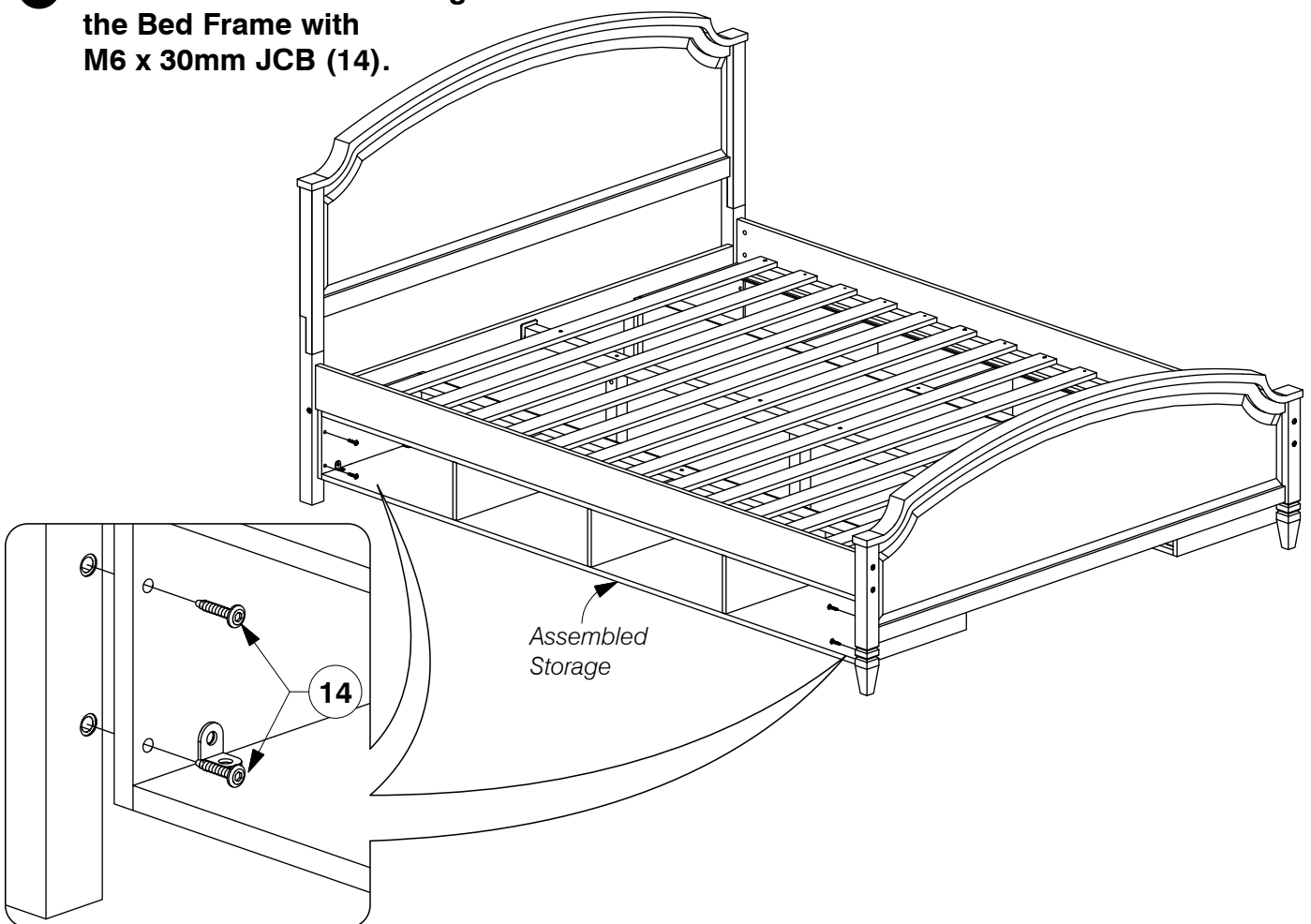

0038 Nightstand

Assembly Instructions

WII-0120

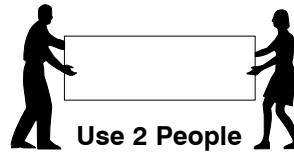
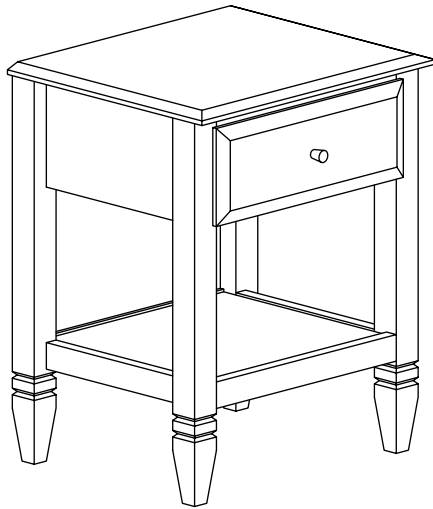

Note: Do not assemble using power tools. This can cause the bolts to be overtightened

1 Parts List

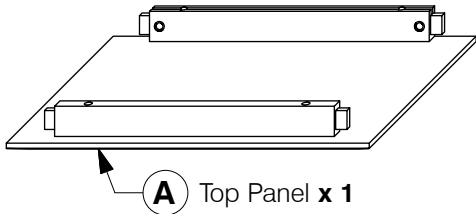

A Top Panel x 1

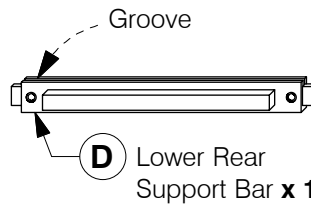

Groove

D Lower Rear Support Bar x 1

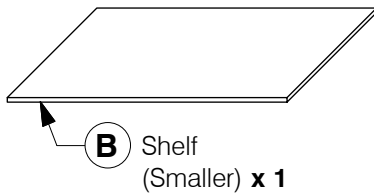

B Shelf (Smaller) x 1



E Lower Front Support Bar x 1

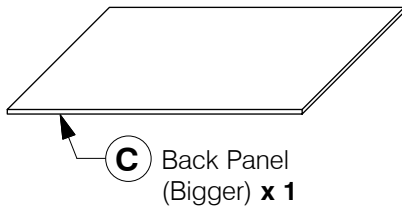

C Back Panel (Bigger) x 1

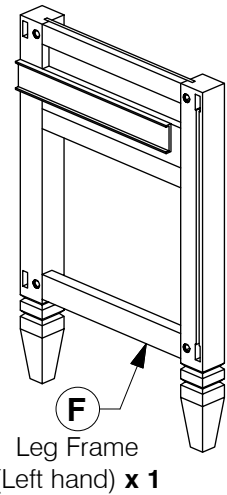

F Leg Frame (Left hand) x 1

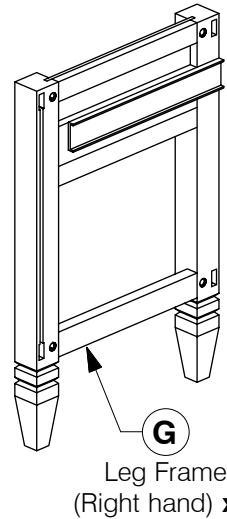

G Leg Frame (Right hand) x 1

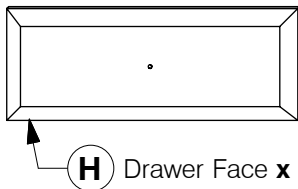

H Drawer Face x 1

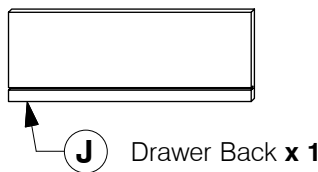

J Drawer Back x 1

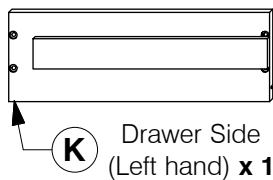

K Drawer Side (Left hand) x 1

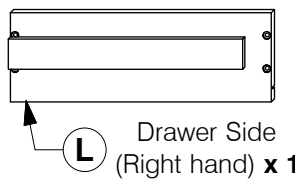

L Drawer Side (Right hand) x 1

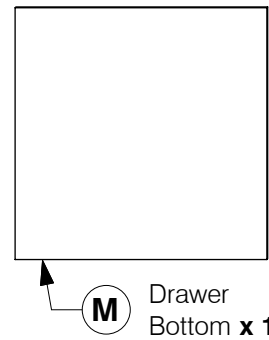

M Drawer Bottom x 1

0038 Nightstand

Assembly Instructions

WII-0120

2 Hardware List

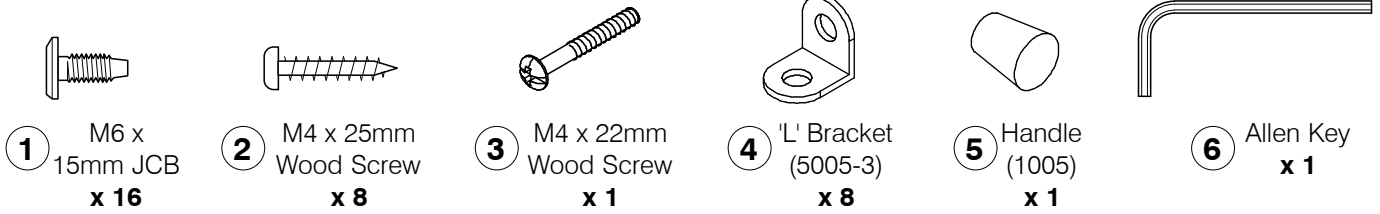

3 Assemble the Drawer Sides (K & L) to the Drawer Face (H).

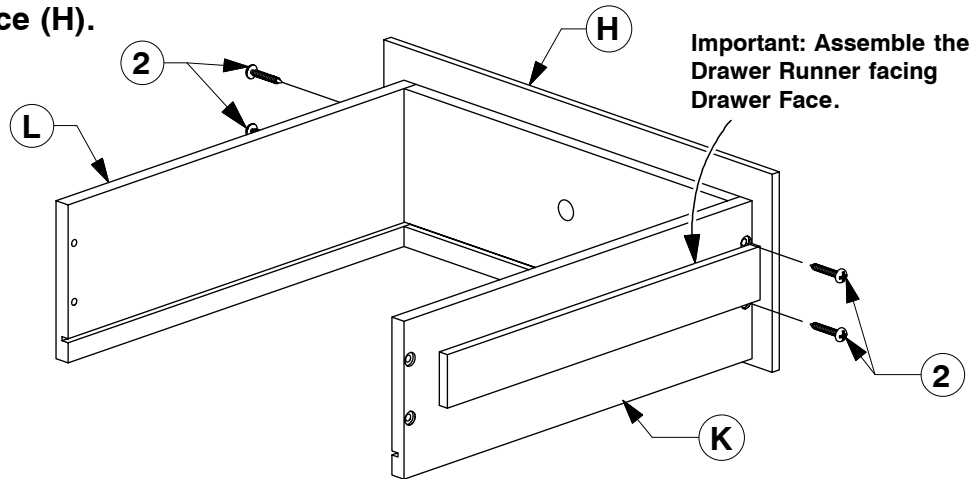

4 Slide the Drawer Bottom (M) into the groove on the Drawer Sides (K & L).

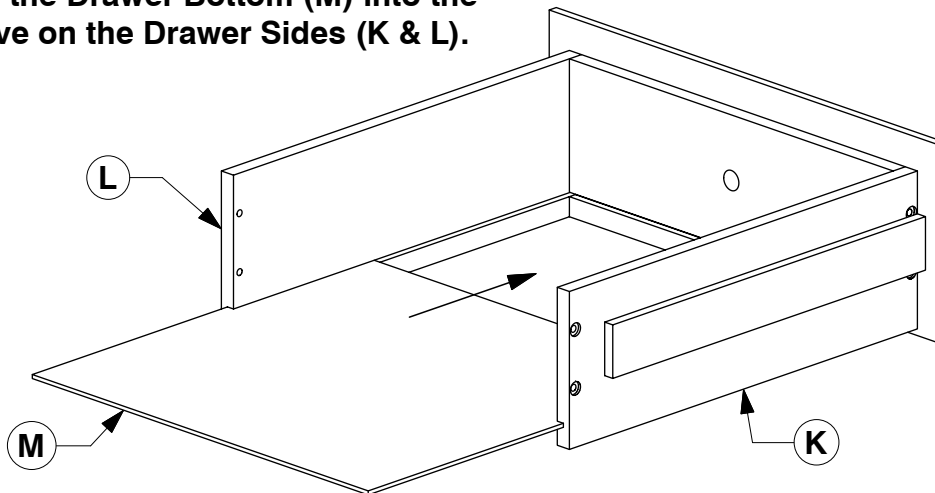

5 Assemble the Drawer Back (J) to the Drawer Sides (K & L).

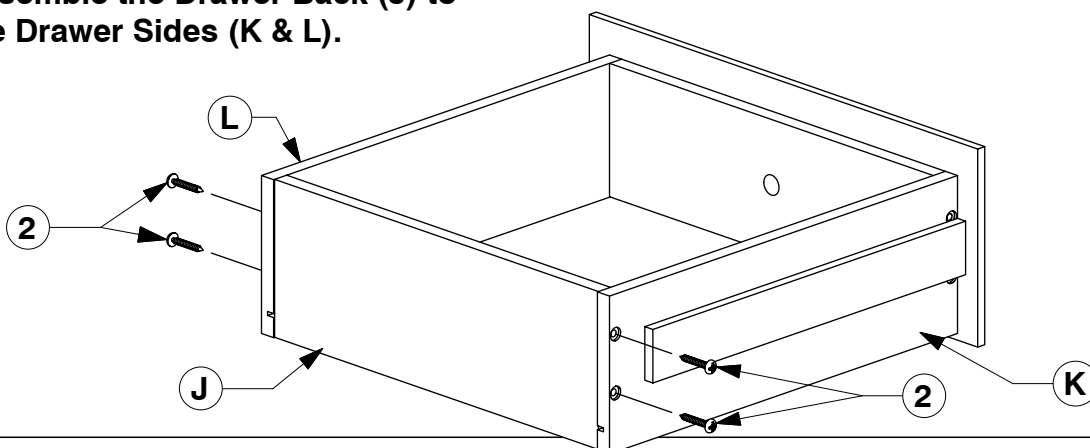

0038 Nightstand

Assembly Instructions

WII-0120

- 6** Fit the 'L' Bracket to the Left & Right hand Leg Frame (F & G).

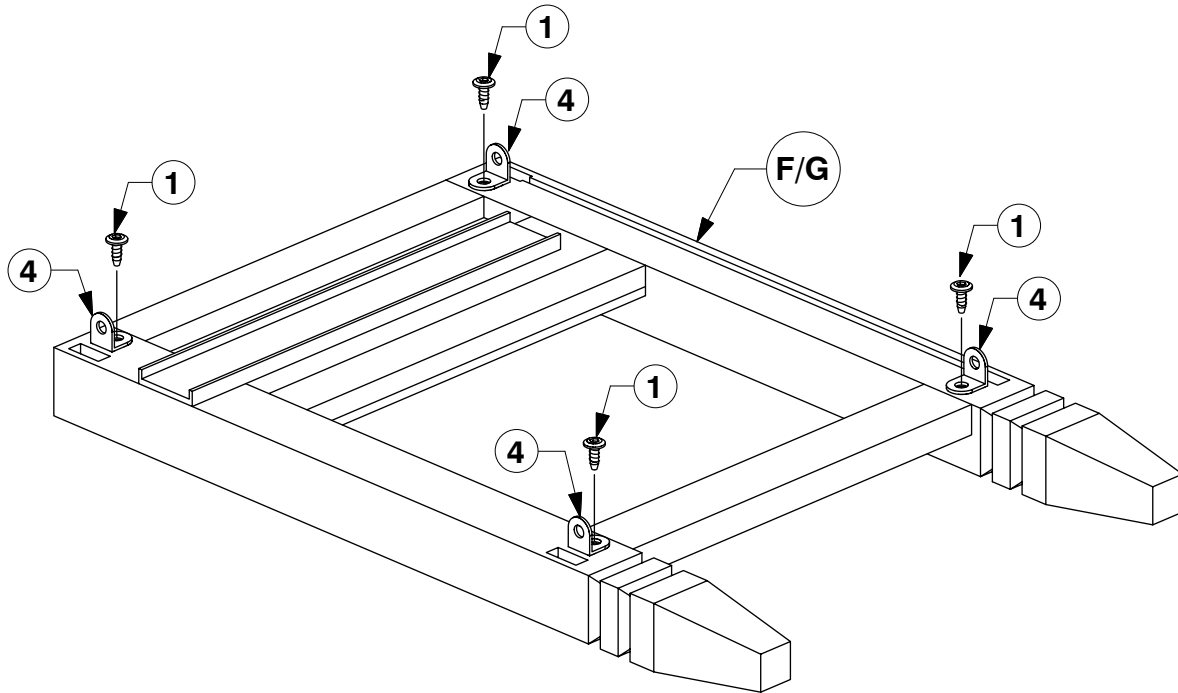

- 7** Fit the Back Panel (C) to the Top Panel (A).

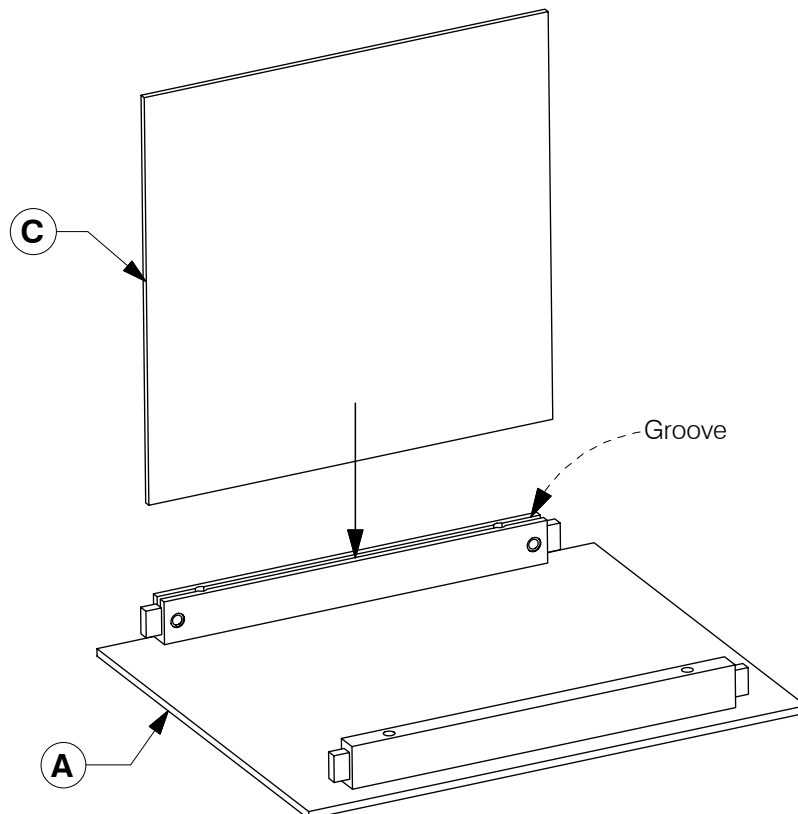

0038 Nightstand

Assembly Instructions

WII-0120

8 Assemble the Left hand Leg Frame (F).

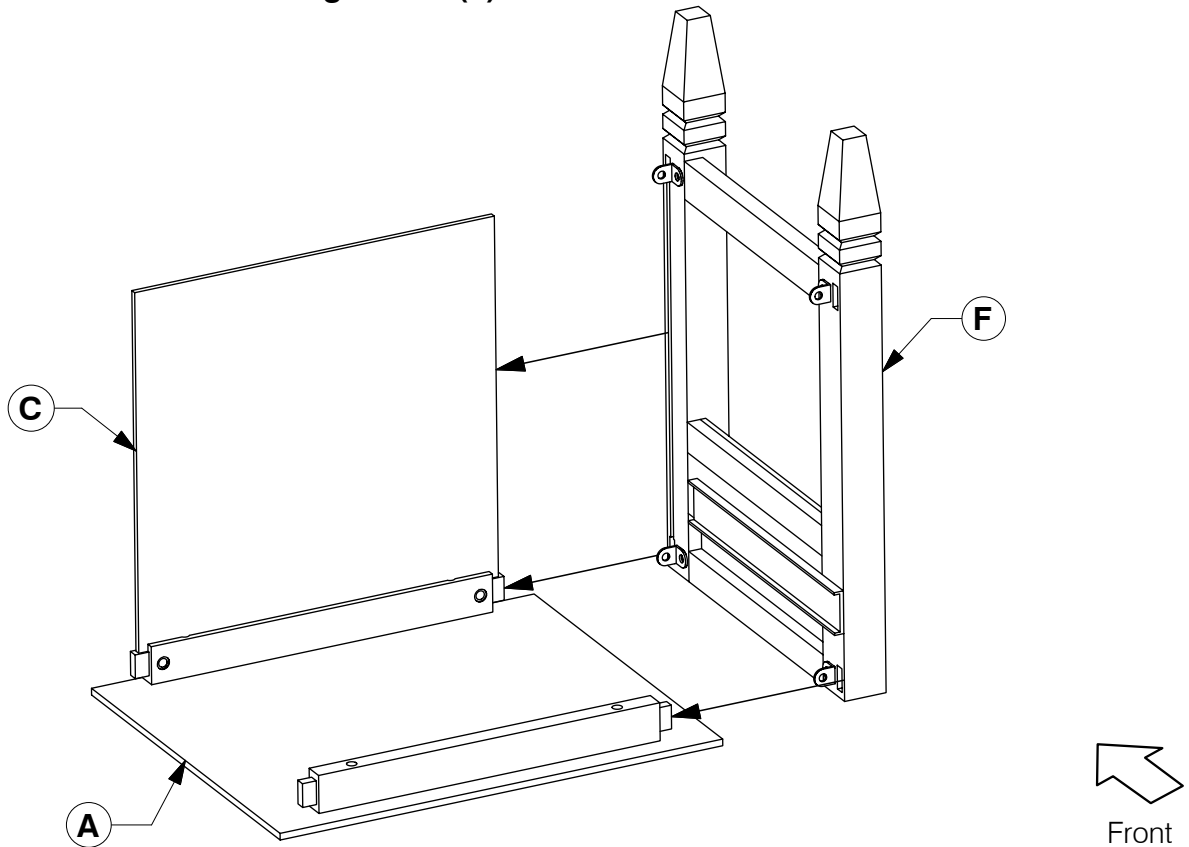

9 Fit the Lower Rear Support Bar (D) to the Left hand Leg Frame (F).

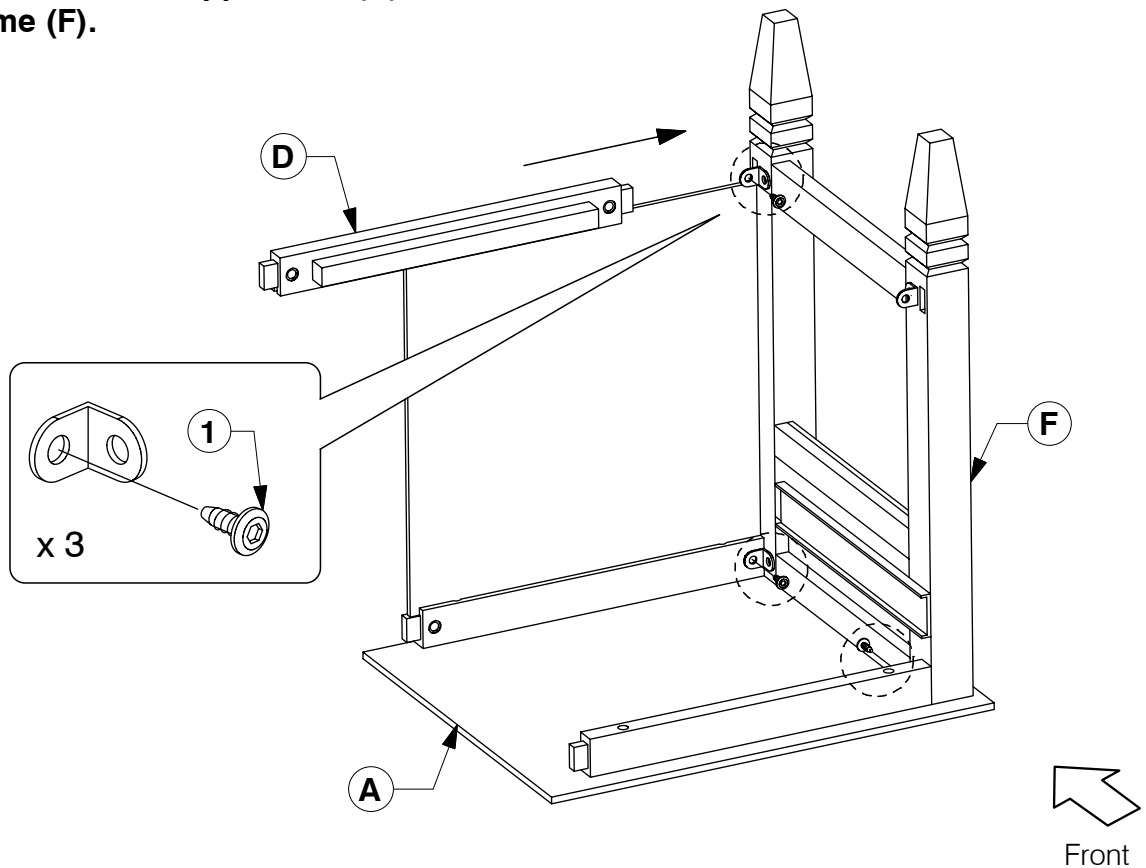

0038 Nightstand

Assembly Instructions

W11-0120

- 10** Fit the Lower Front Support Bar (E) to the Left hand Leg Frame (F). Assemble the Right hand Leg Frame (G) to the frame.

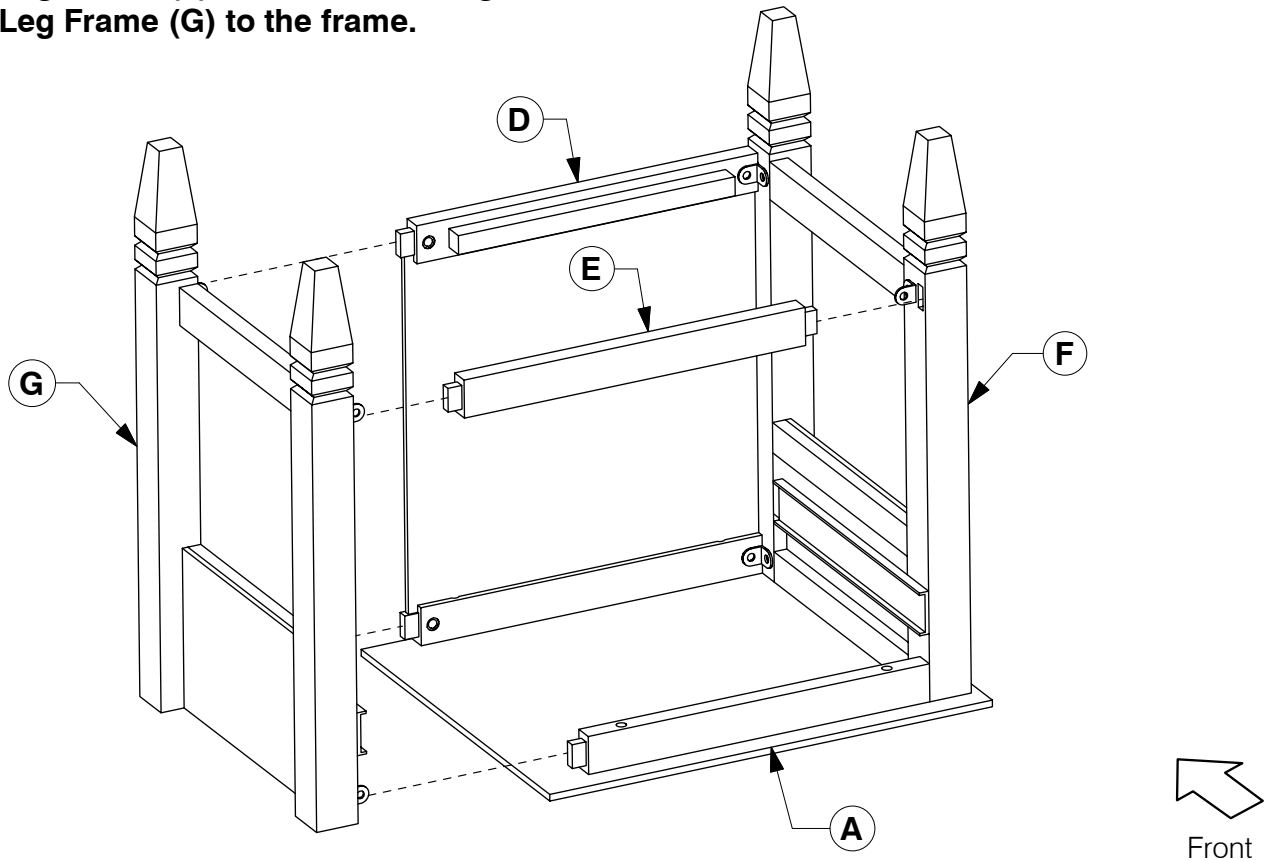

- 11** Tighten all the bolts with using 15mm JCB.

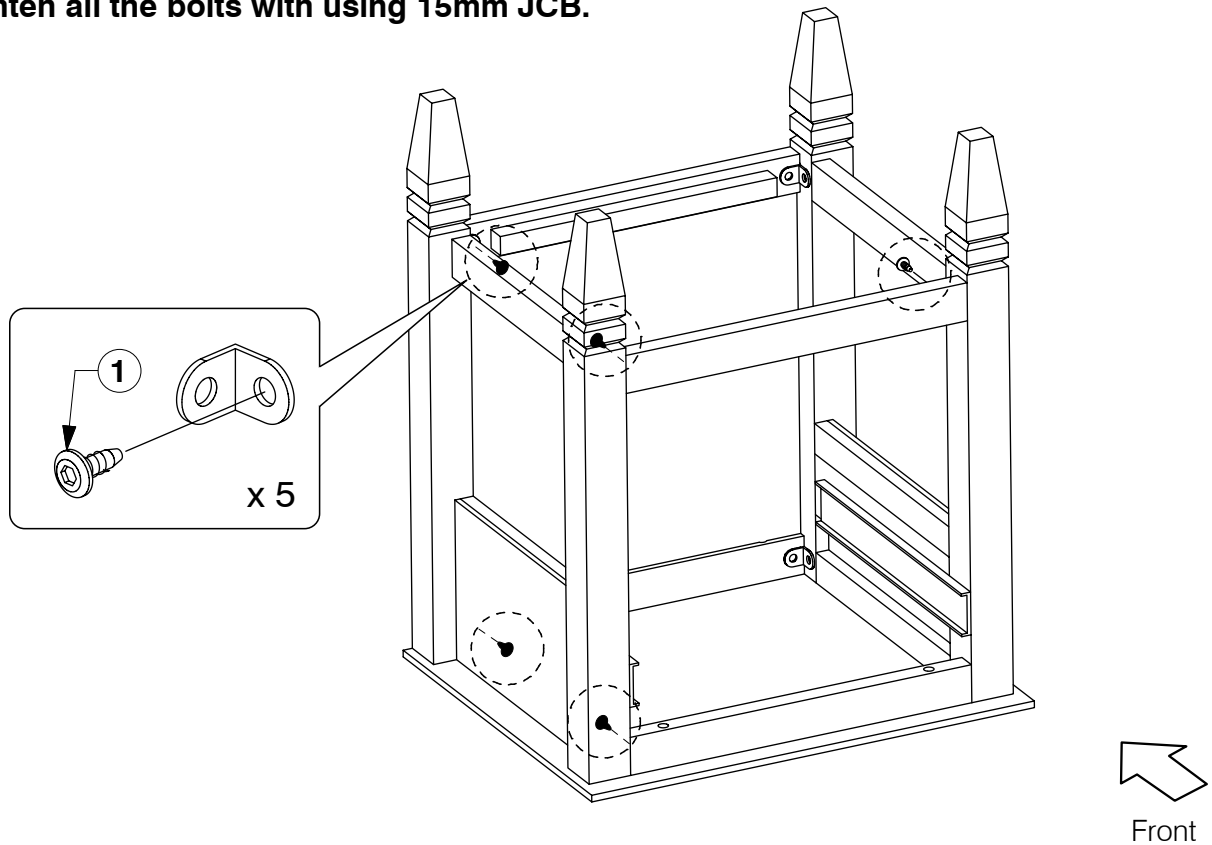

0038 Nightstand

Assembly Instructions

WII-0120

12 Fit the Shelf (B).

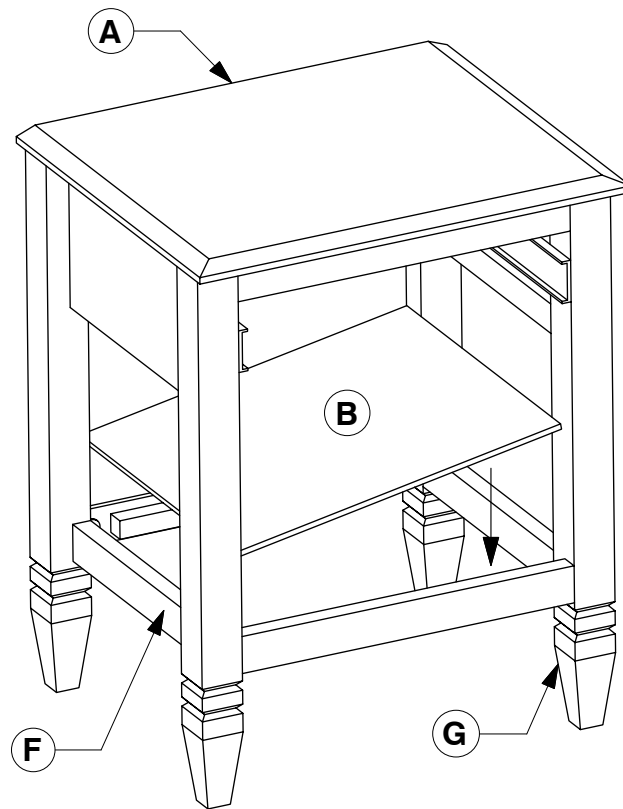

Front

13 Fit the Handle to the Drawer face (H). Finally, fit the assembled Drawer.

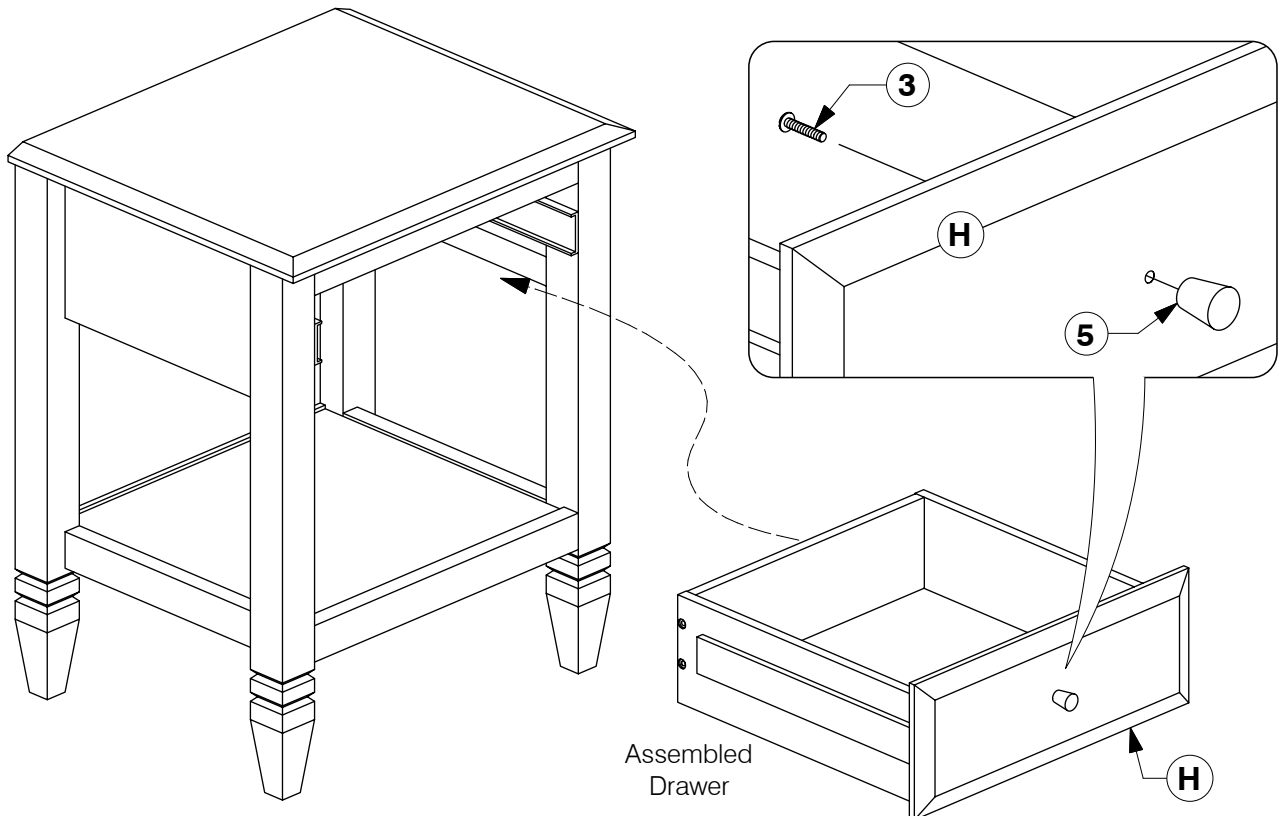

Assembled
Drawer

0038 6 Drawer Dresser

Assembly Instructions

WII-0120

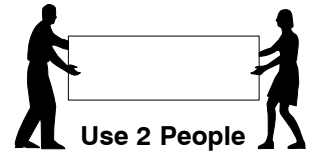
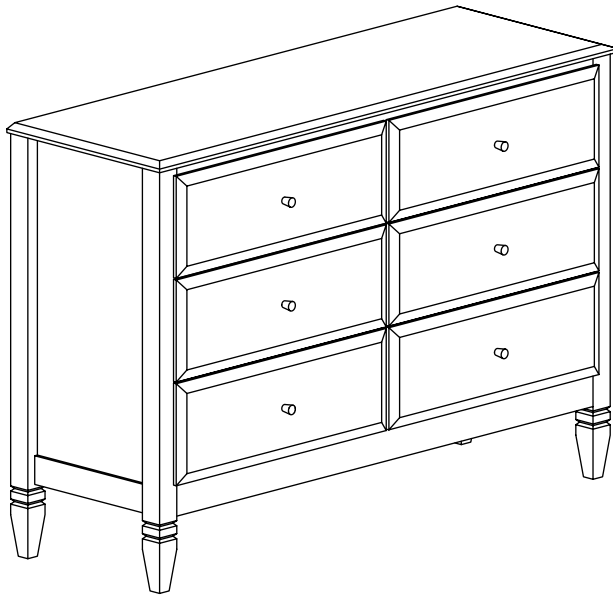

Note: Do not assemble using power tools. This can cause the bolts to be overtightened

1 Parts List

Parts in Box A:

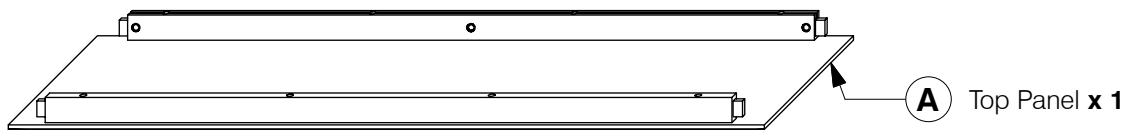

A Top Panel x 1

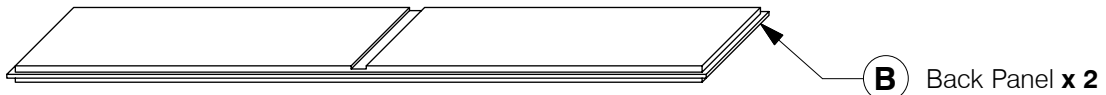

B Back Panel x 2

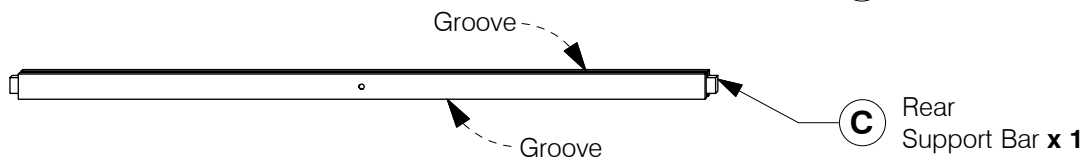

C Rear Support Bar x 1

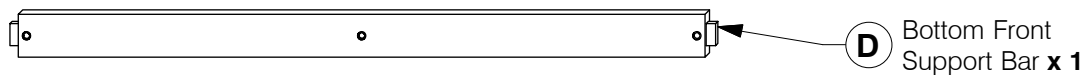

D Bottom Front Support Bar x 1

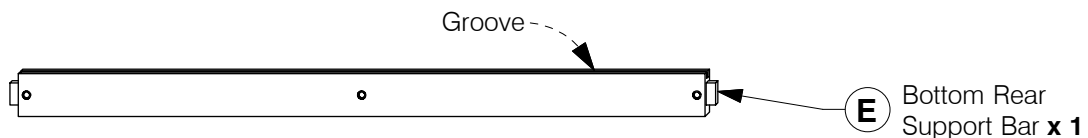

E Bottom Rear Support Bar x 1

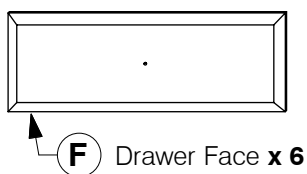

F Drawer Face x 6

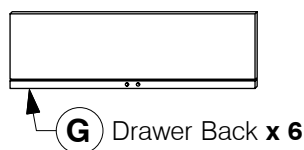

G Drawer Back x 6

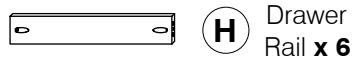

H Drawer Rail x 6

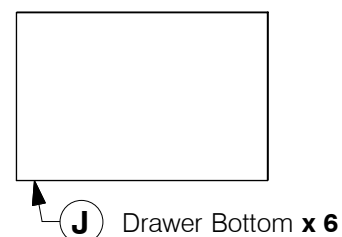

J Drawer Bottom x 6

0038 6 Drawer Dresser

Assembly Instructions

WII-0120

1 Parts List

Parts in Box B:

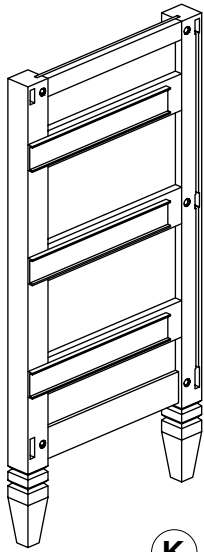

K

Leg Frame
(Left Hand) x 1

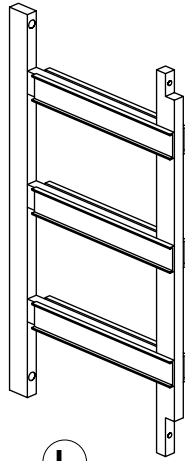

L

Center Frame
x 1

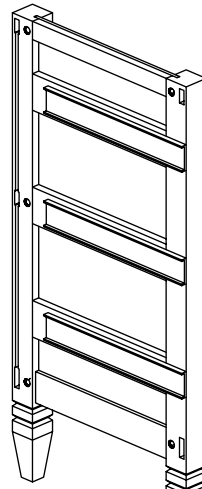

M

Leg Frame
(Right Hand) x 1

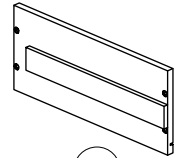

N

Drawer Side
(Left Hand) x 6

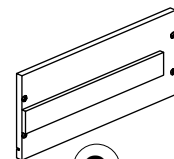

O

Drawer Side
(Right Hand) x 6

2 Hardware List



1 M6 x
15mm JCB
x 20



2 M6 x
30mm JCB
x 4



3 M6 x
40mm JCB
x 1



4 M6 x 25mm
Wood Dowel
x 24

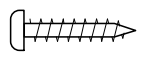

5 M4 x 25mm
Wood Screw
x 60

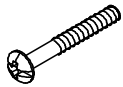

6 M4 x 22mm
Wood Screw
x 6

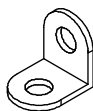

7 'L' Bracket
(5005-3) x 10



8 Handle
(1005) x 6



9 Allen Key
x 1

3 Assemble the Drawer Sides (N & O) & Drawer Rail (H) to the Drawer Face (F).

x6

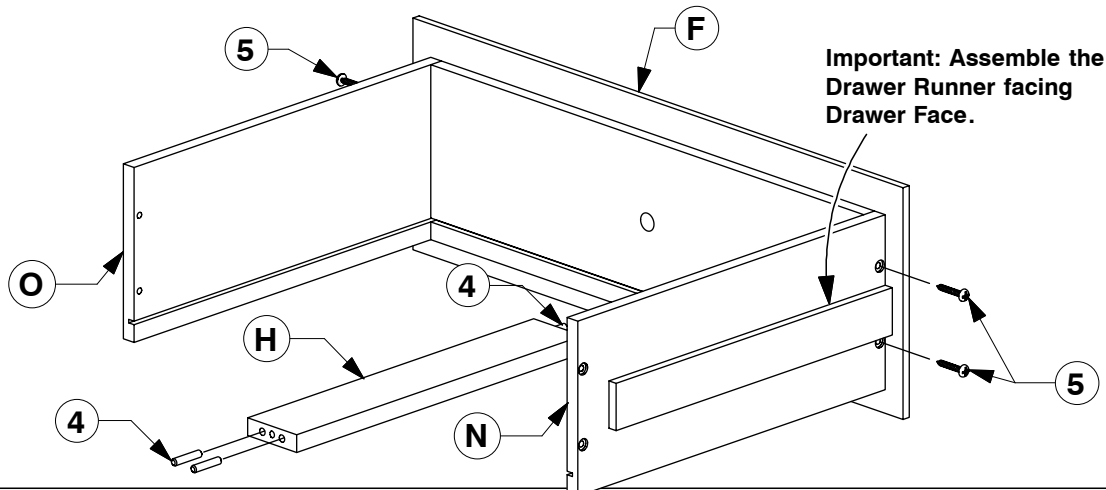

0038 6 Drawer Dresser

Assembly Instructions

WII-0120

- 4** Slide the Drawer Bottom (J) into the groove on the Drawer Sides (N & O).

x6

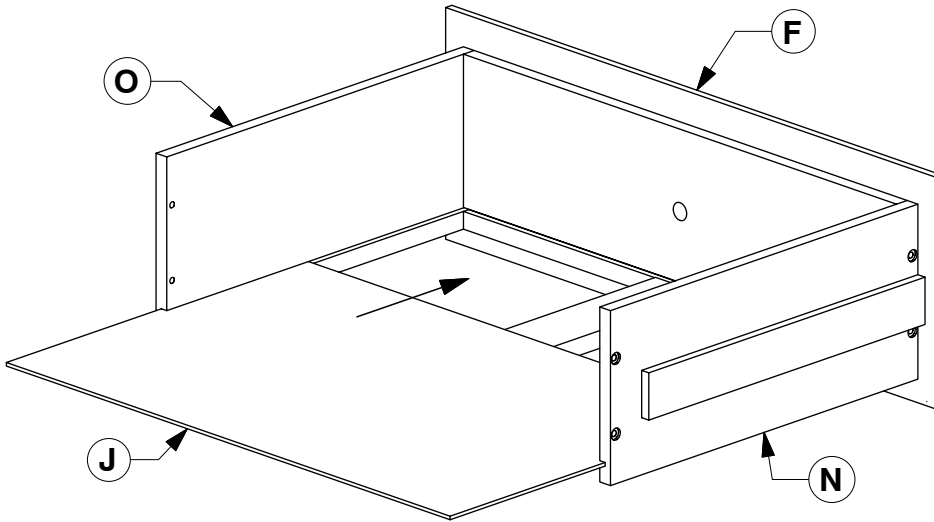

- 5** Assemble the Drawer Back (G) to the Drawer Sides (N & O).

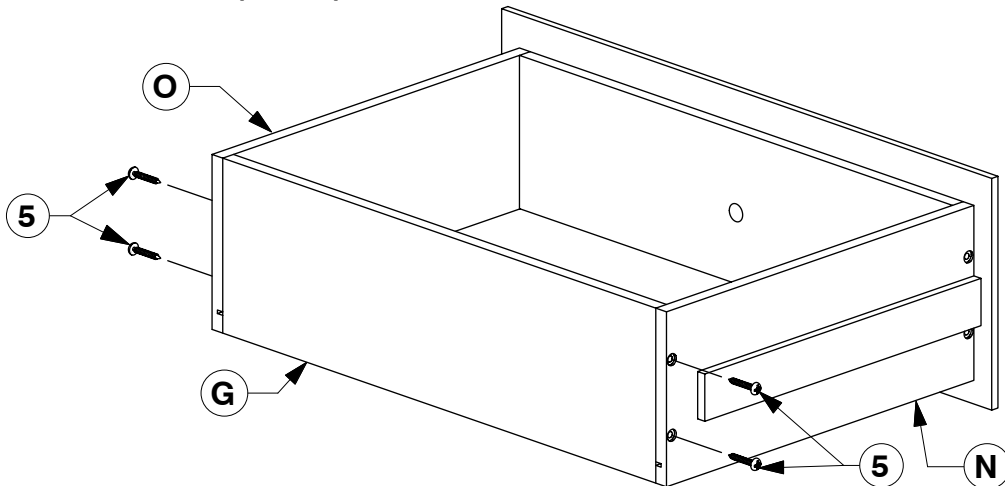

- 6** Turn the Drawer over to fit angled 25mm Wood screws (5) to the Drawer Rail (H).

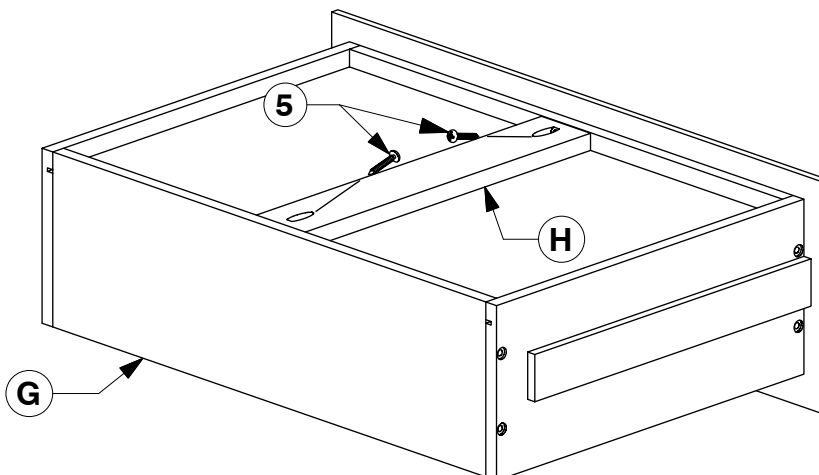

0038 6 Drawer Dresser

Assembly Instructions

WII-0120

- 7** Fit the 'L' Bracket to the Top Panel (A).

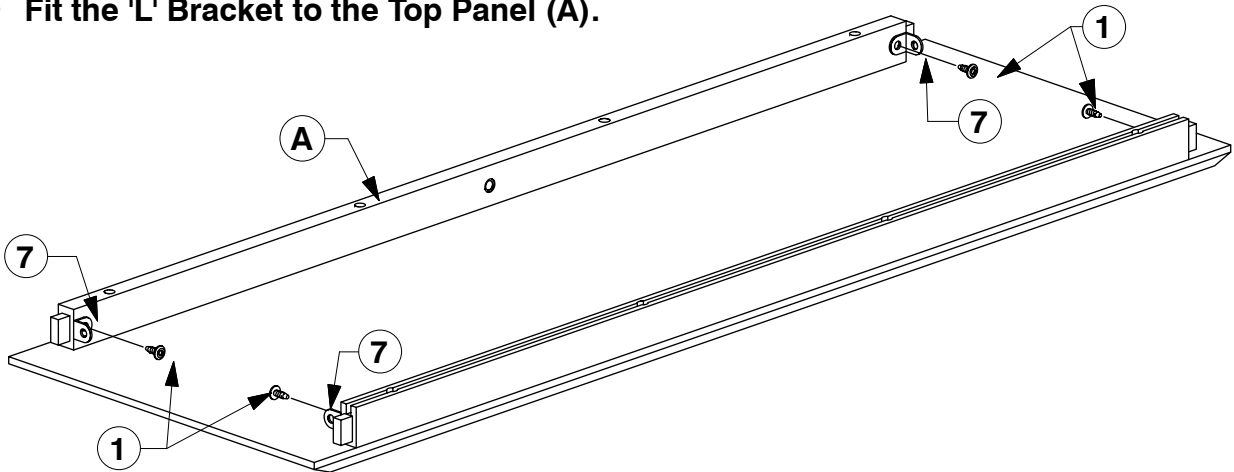

- 8** Fit the 'L' Bracket to the Rear Support Bar (C) as shown below.

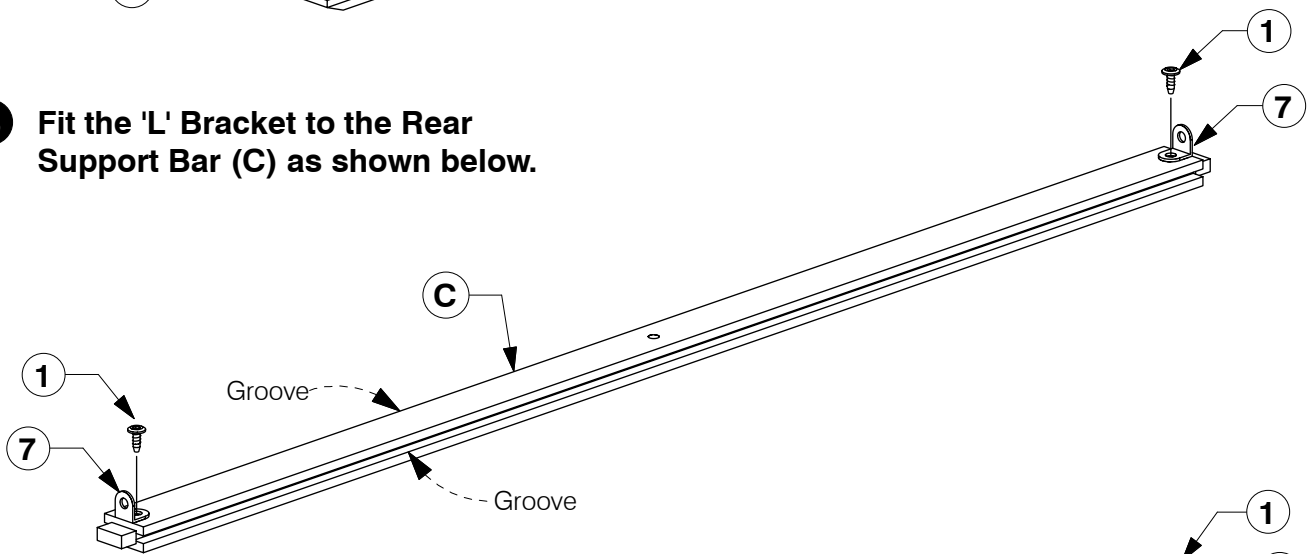

- 9** Fit the 'L' Bracket to the Bottom Front & Rear Support Bar (D & E) as shown below.

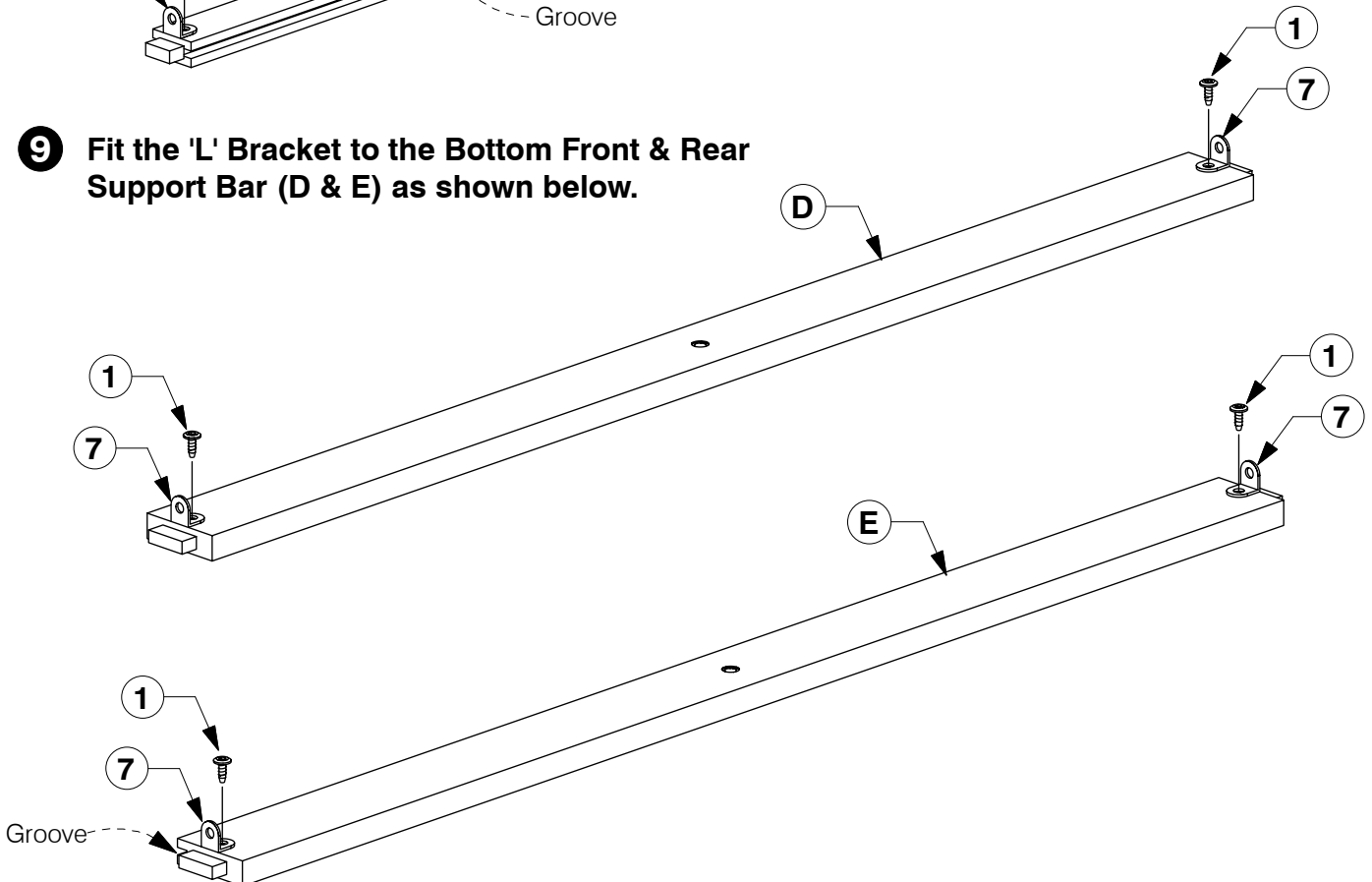

0038 6 Drawer Dresser

Assembly Instructions

WII-0120

- 10** Slide the Back Panel (B) into the groove on Top Panel (A) & Left hand Leg Frame (K).

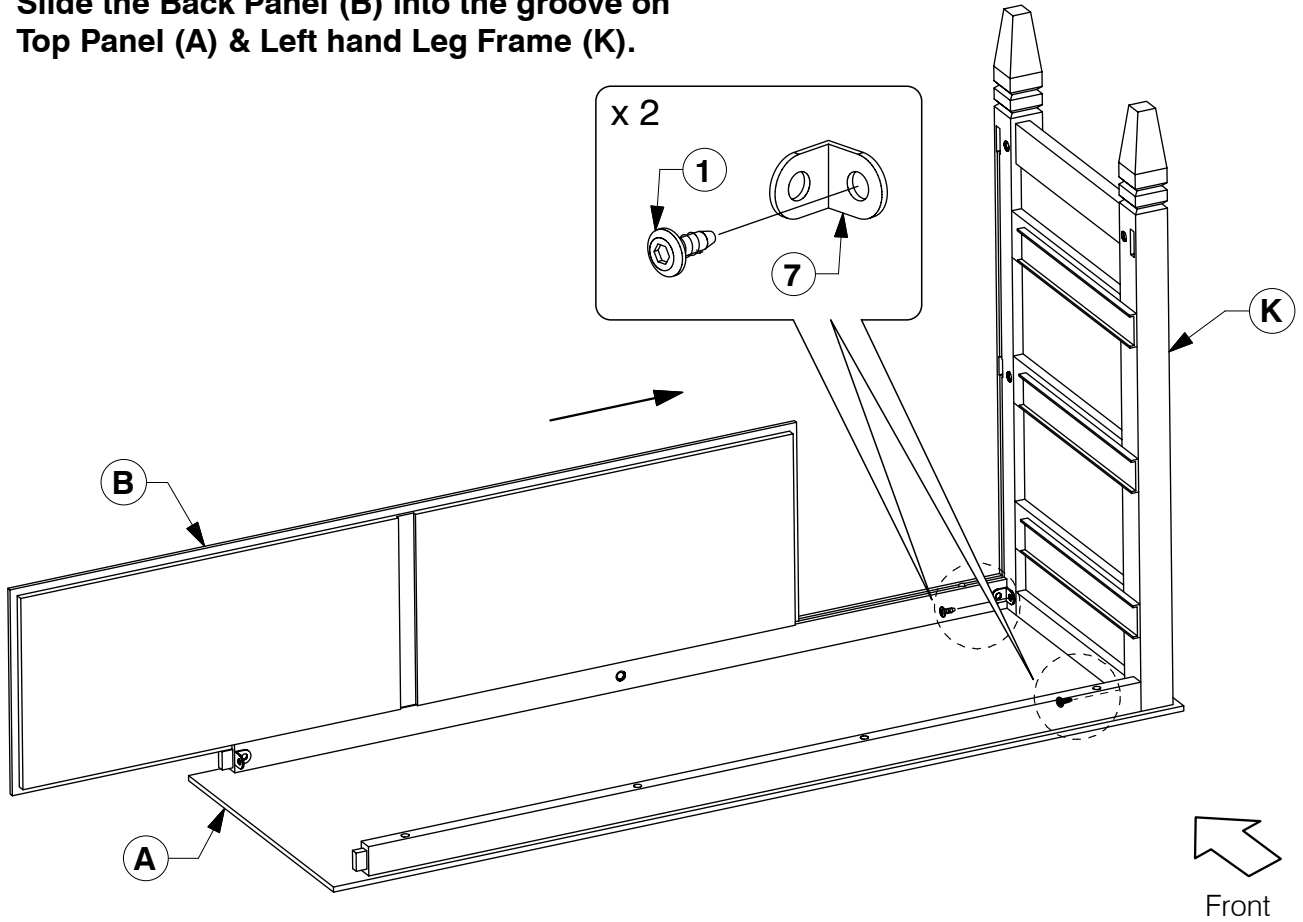

- 11** Slide the Rear Support Bar (C) into the groove on Back Panel (B).

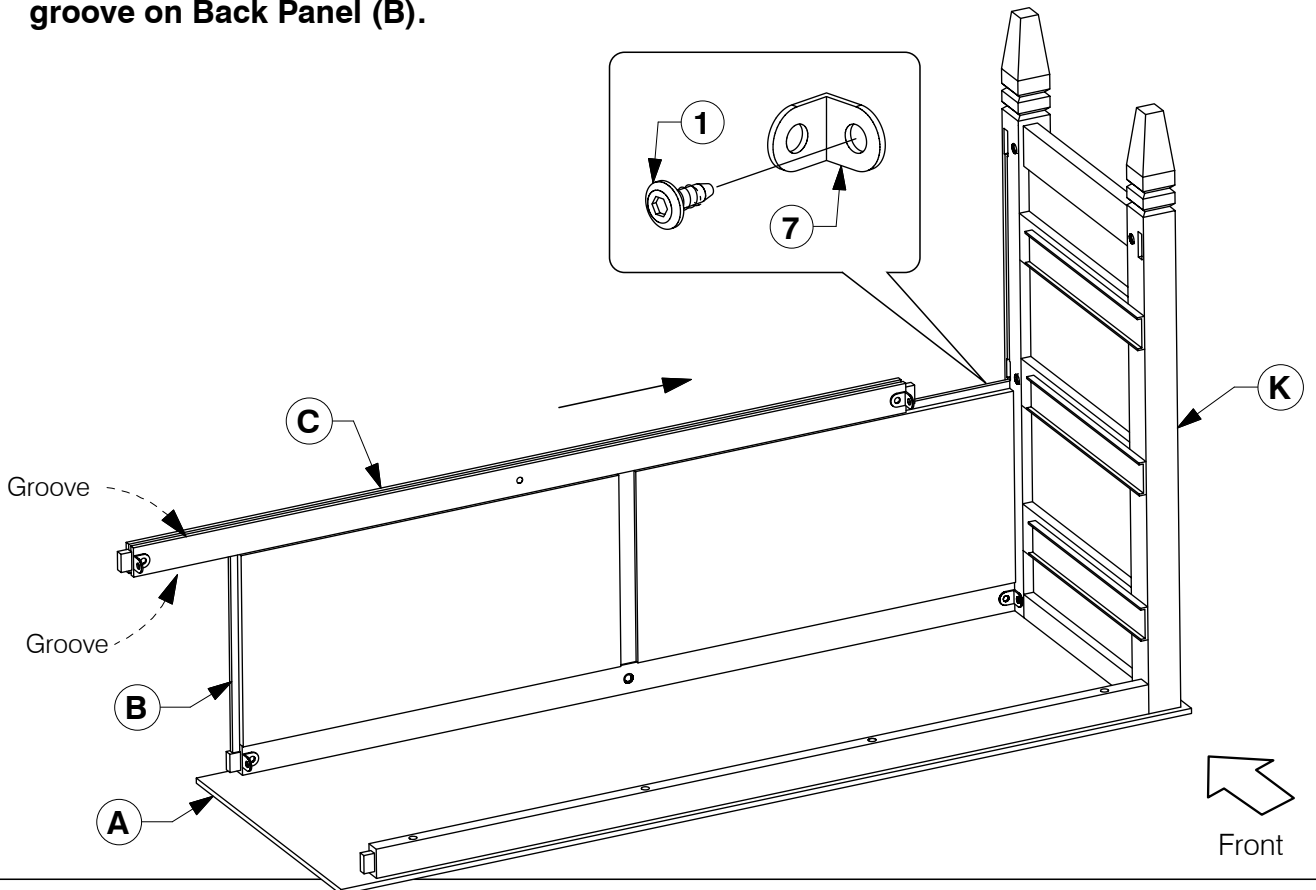

0038 6 Drawer Dresser

Assembly Instructions

WII-0120

- 12** Slide the Back Panel (B) into the groove on Rear Support Bar (C).

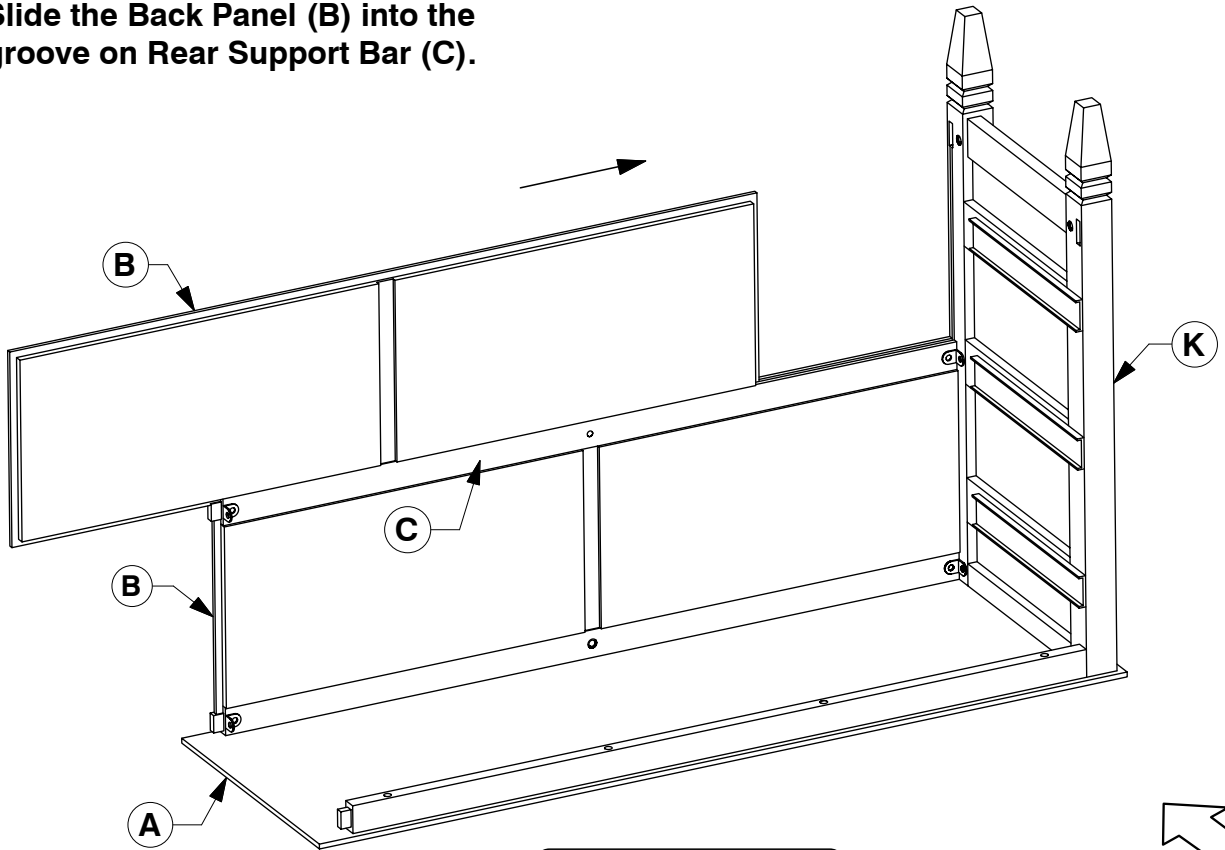

- 13** Attach the Bottom Front & Rear Support Bar (D & E) to the Left hand Leg Frame (K).

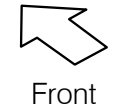
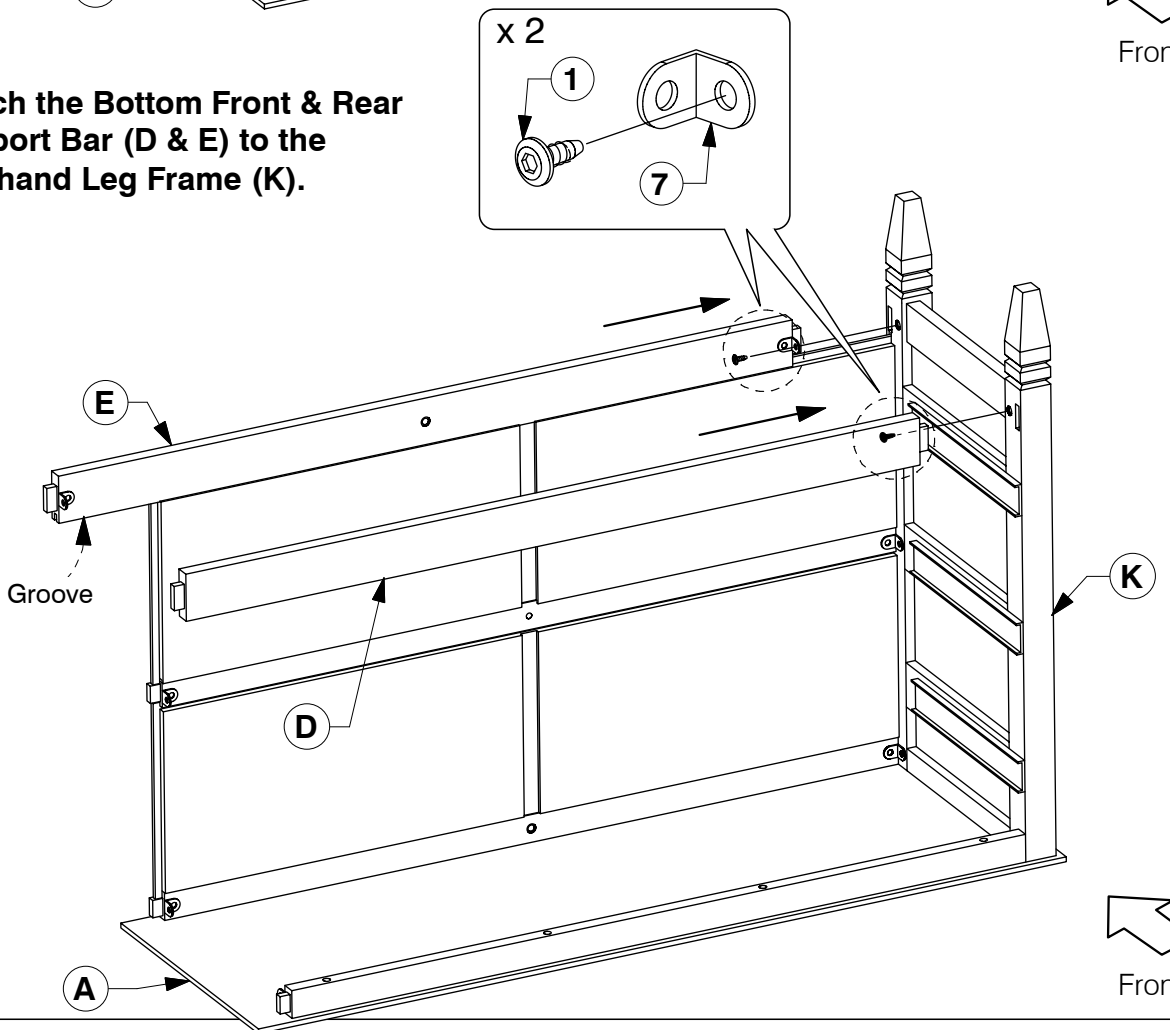

Front



Front

0038 6 Drawer Dresser

Assembly Instructions

WII-0120

14 Fit the Center Frame (L) to the frame.

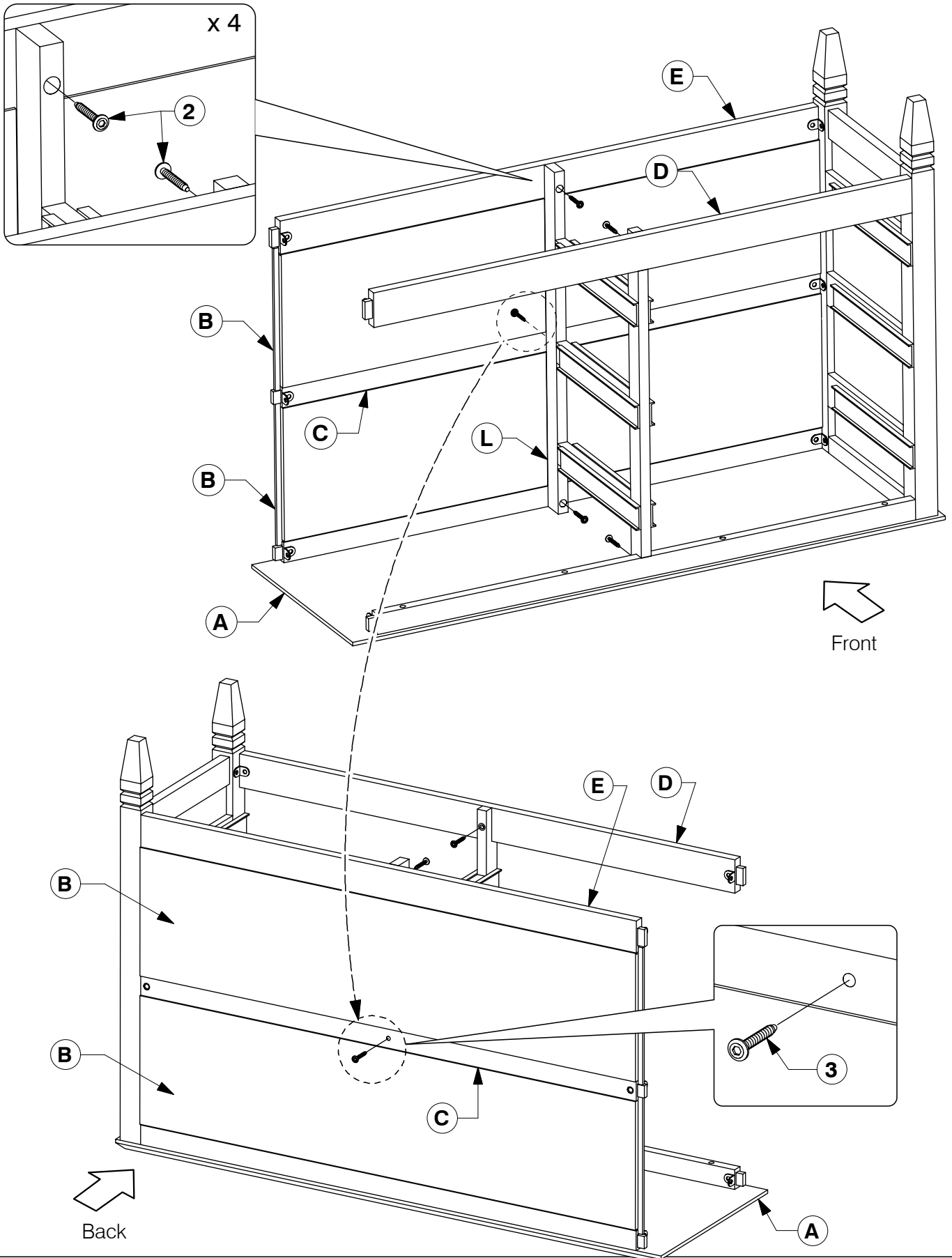

0038 6 Drawer Dresser

Assembly Instructions

WII-0120

15 Fit the Right hand Leg Frame (M) to the frame.

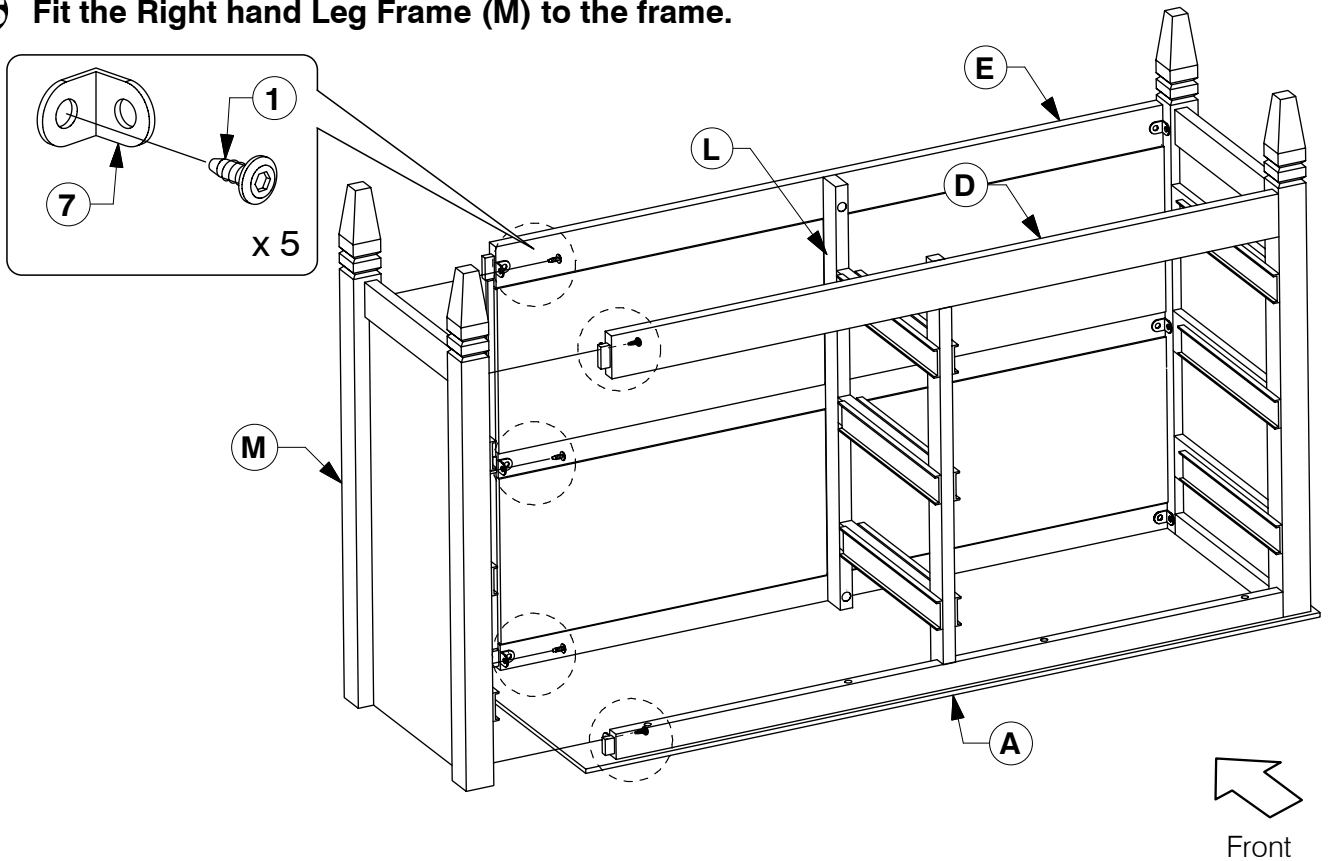

16 Fit the Handle to the Drawer face (F).
Finally, fit the assembled Drawer.

