

# ASSEMBLY INSTRUCTIONS

Model no : BW19-02T

Read this instruction carefully. Remove all wrapping material, staples and straps from the carton.





See hardware and furniture part list.

For guidance. Be sure you have all wooden furniture parts on a clean and flat soft surface, such as a carpet or rug, to prevent from being scratched. Follow the figure to start assembling.

### CAUTION :

1. Do not FULLY - TIGHTEN the nut or screw until all is ready to assemble.
2. Do not OVER - TIGHTEN the nut or screw to avoid causing damages to the thread.
3. Keep all hardware part out reach of children.

| No | Part List | Qty |
|----|-----------|-----|
| 1  | Table Top | 1   |
| 2  | Table Leg | 4   |

| No | Description  | Qty |
|----|--|-----|
| A  | M5 ALLEN KEY          | 1   |
| B  | JCBC Screw M8 x 60mm  | 8   |
| C  | Spring Washer         | 8   |
| D  | Flat Washer           | 8   |

## Step 1

Attach part 1 and 2 for all four sides and lock it using hardware A, B, C, and D.

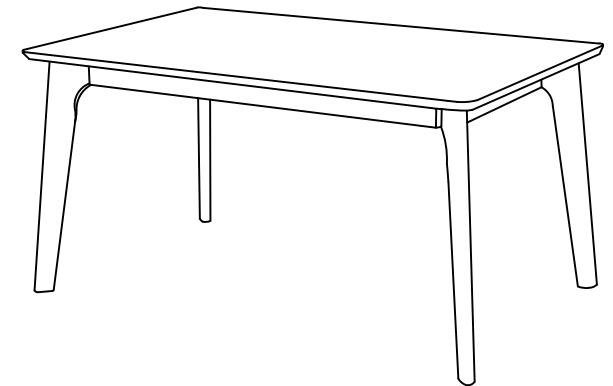
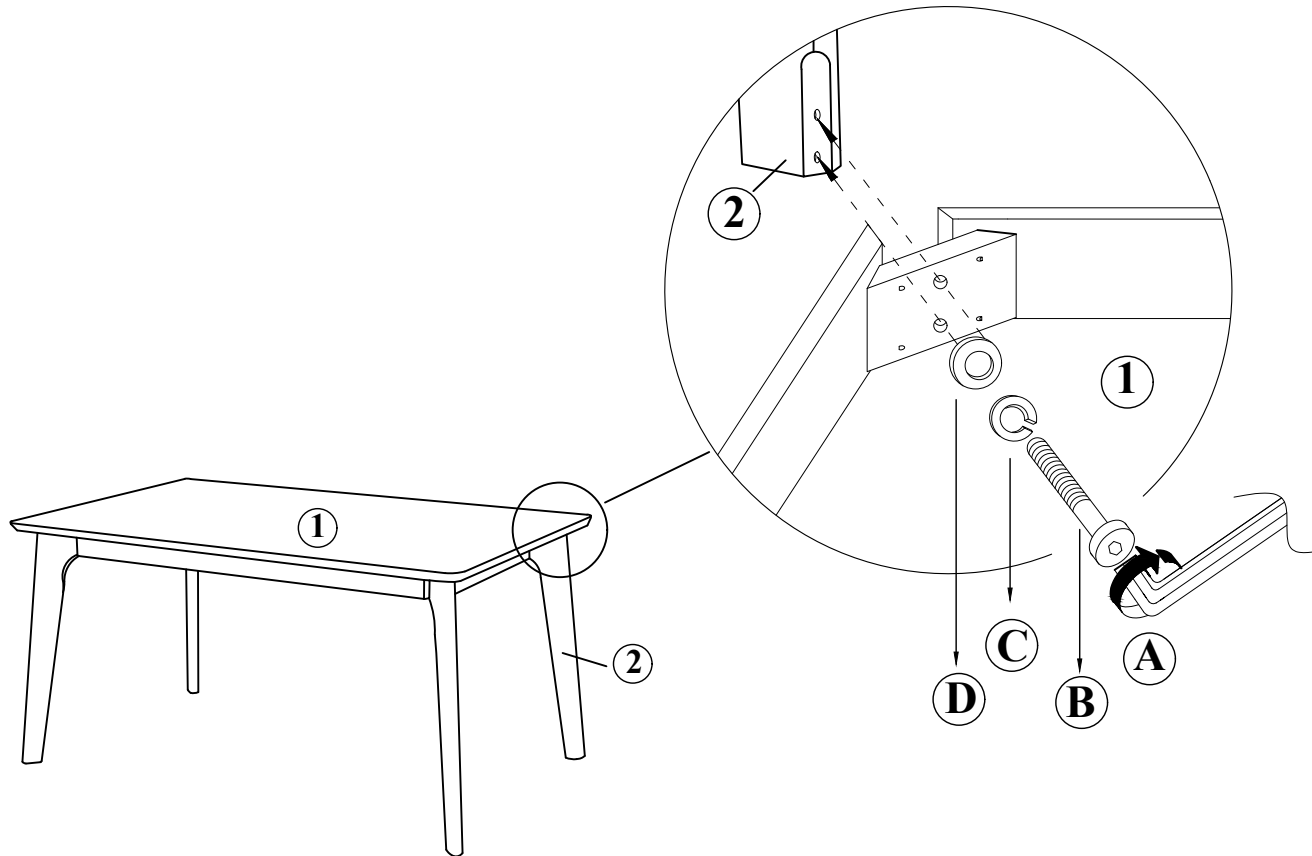

COMPLETE  
ASSEMBLE

# ASSEMBLY INSTRUCTIONS

Model no : BW19-56C

Read this instruction carefully. Remove all wrapping material, staples and straps from the carton.



See hardware and furniture part list.

For guidance. Be sure you have all wooden furniture parts on a clean and flat soft surface, such as a carpet or rug, to prevent from being scratched. Follow the figure to start assembling.

**CAUTION :**

1. Do not FULLY - TIGHTEN the nut or screw until all is ready to assemble.
2. Do not OVER - TIGHTEN the nut or screw to avoid causing damages to the thread.
3. Keep all hardware part out reach of children.

| No | Part List    | Qty |
|----|--------------|-----|
| 1  | Back Rail    | 1   |
| 2  | Side Frame   | 2   |
| 3  | Front Rail   | 1   |
| 4  | Back Rest    | 1   |
| 5  | Cushion Seat | 1   |

| No | Description  | Qty |
|----|--|-----|
| A  | M4 ALLEN KEY          | 1   |
| B  | JCBC Screw M6 x 50mm  | 12  |
| C  | CSK Screw M4 x 32mm   | 4   |
| D  | Wood Dowel 8 x 30mm   | 4   |
| E  | Spring Washer         | 12  |
| F  | Wood Button           | 4   |

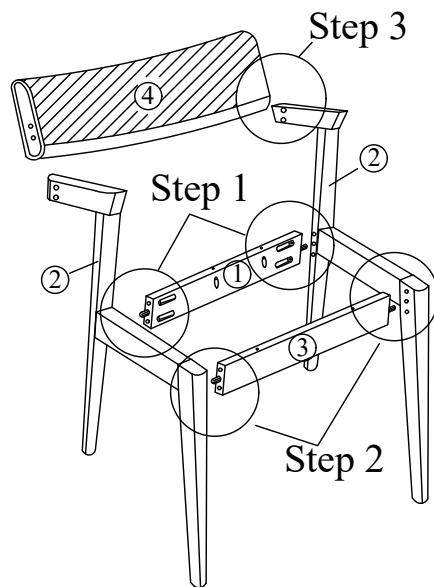

**Step 1**

Firstly, attach part 1 and 2 for both left and right side as shown and lock using hardware A, B, D, and E.

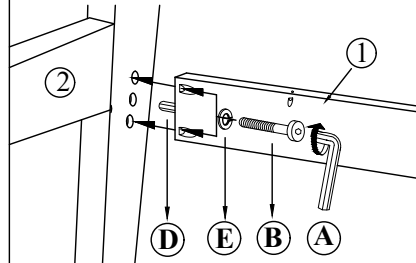

**Step 2**

Attach part 2 and 3 for both left and right side and repeat as step 1, lock it using hardware A, B, D, and E.

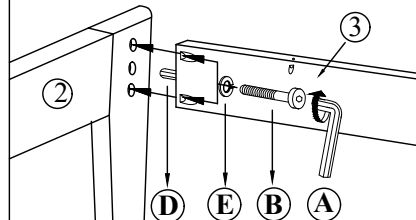

**Step 3**

Locate part 4 in between both part 2 as shown, and fully-tighten it with hardware A, B, and E.

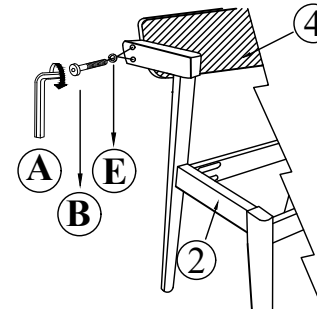

**Step 4**

Locate part 5 on the assembled seating frame as shown, and fully tighten it with hardware C. Lastly, use hardware F to cover up the holes beside part 4 as shown.

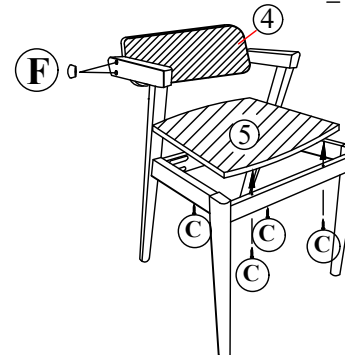

**Step 5**

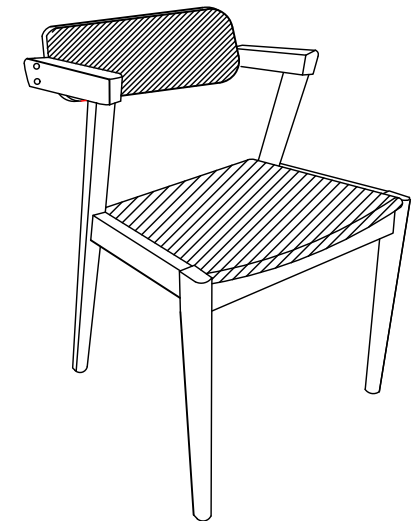

**COMPLETE ASSEMBLE**