

0076 Daybed

Assembly Instructions

WI-1220

1 Assembled View

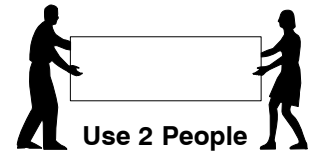
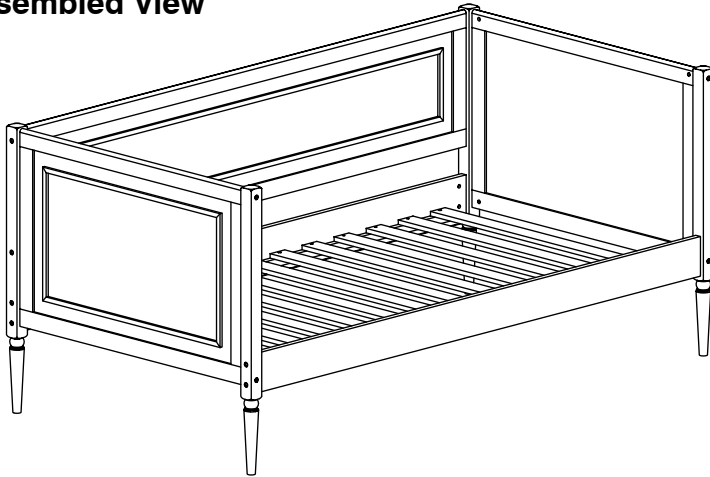

Note: Do not assemble using power tools. This can cause the bolts to be overtightened

2 Parts in this Box

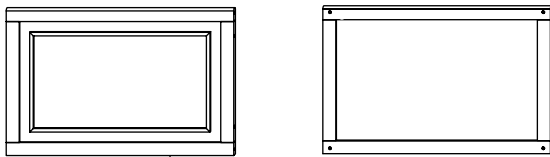

A Side Panel x 2

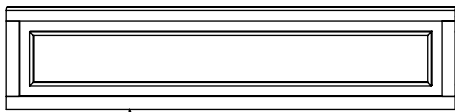

B Back Panel x 1



C Side Rail x 2

Slats are packed in separately in Box B

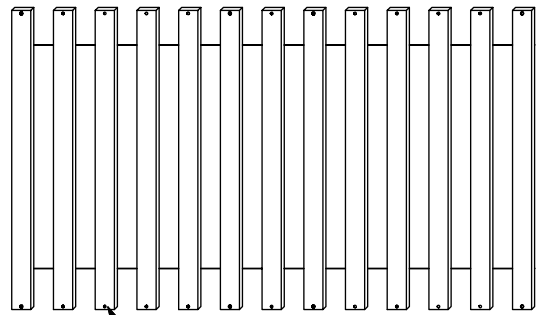

H Set of Slats x 1

3 Hardware in this Box



1 M6 x 90mm JCB
x 20



4 Barrel Nut x 20

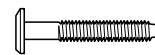

2 M6 x 40mm JCB
x 8



5 Wood Dowel
(10 x 40mm)
x 16

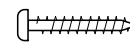

3 Wood Screw
(M4 x 32mm)
x 18



6 Allen Key
x 1

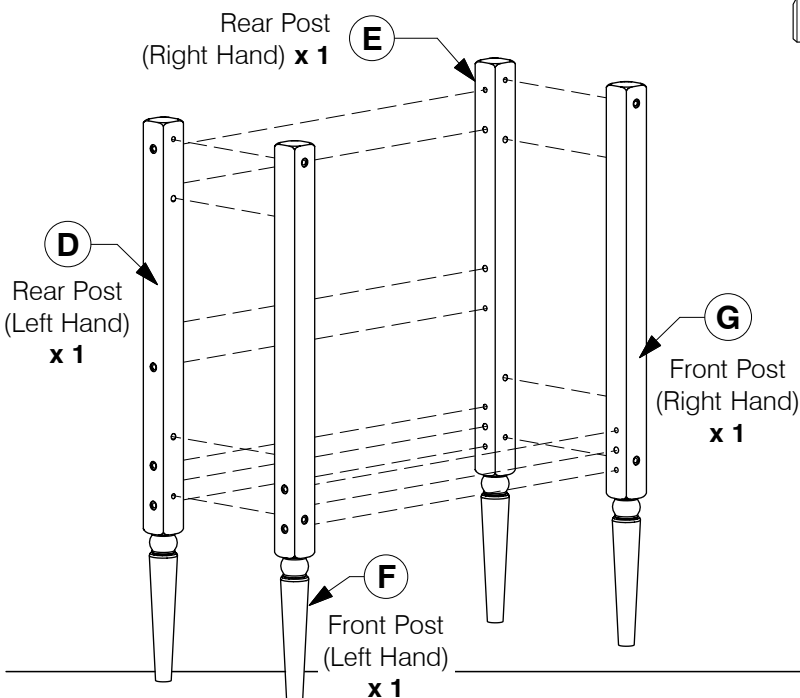

0076 Daybed

Assembly Instructions

WI-1220

- 4** Assemble the Rear Post (D/E) to the Side Panel (A).

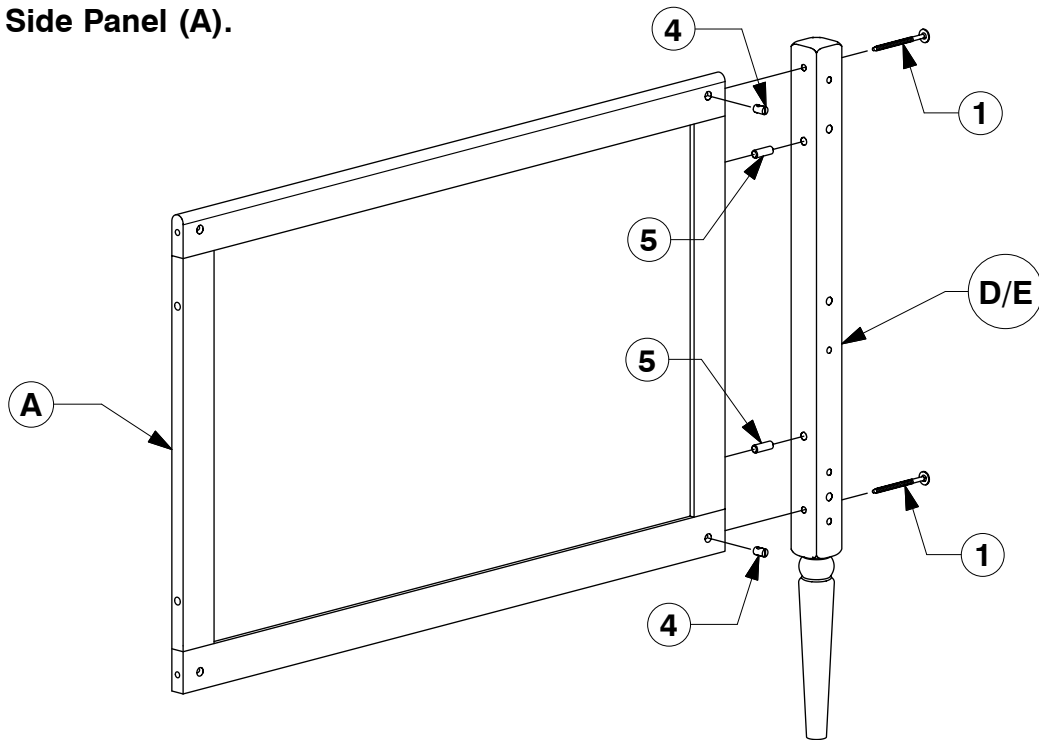

- 5** Assemble the Front Post (F/G) to the Side Panel (A).

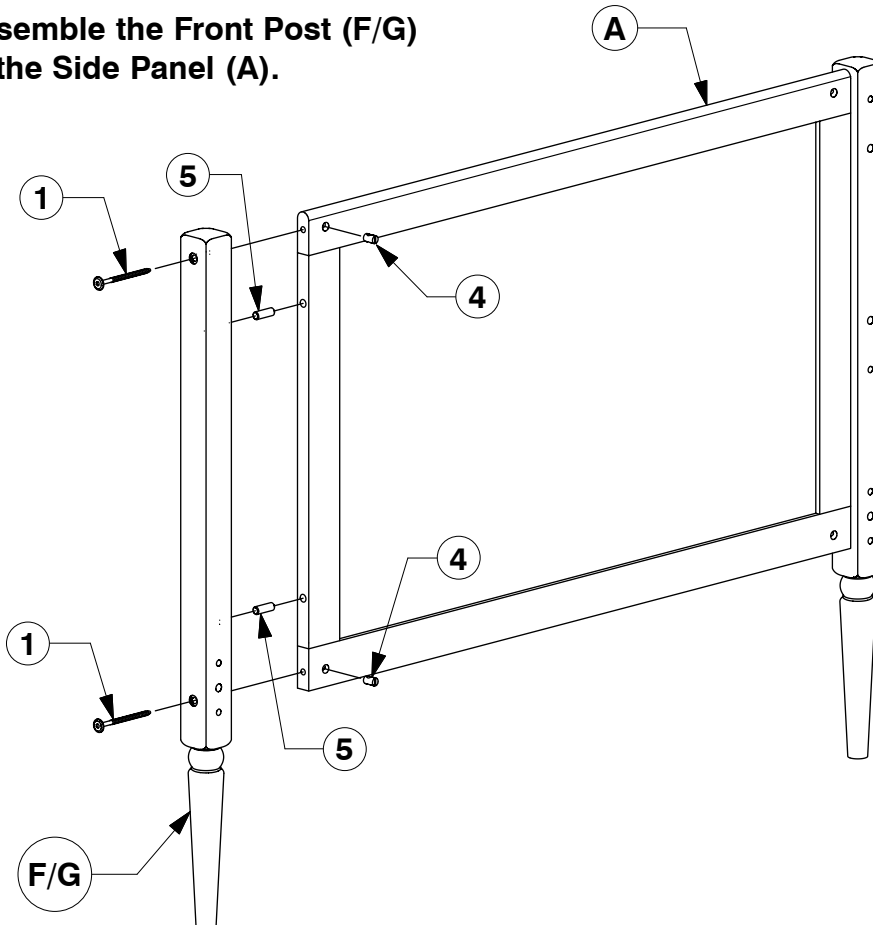

0076 Daybed

Assembly Instructions

WI-1220

- 6** Assemble the Side Panel (A) to the Back Panel (B) & Side Rail (C).

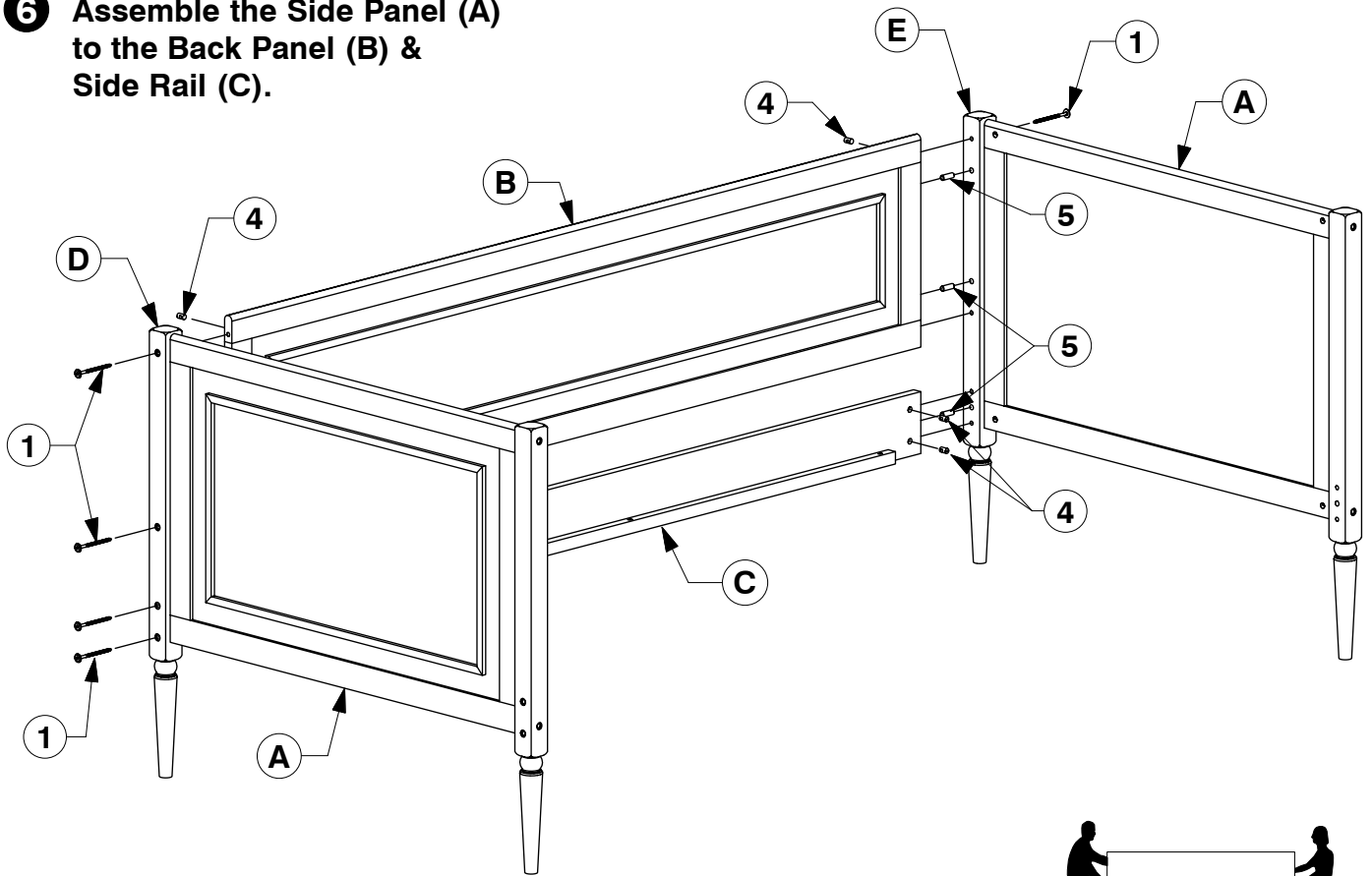

- 7** Assemble the Side Rail (C) to the Front Post (F & G).

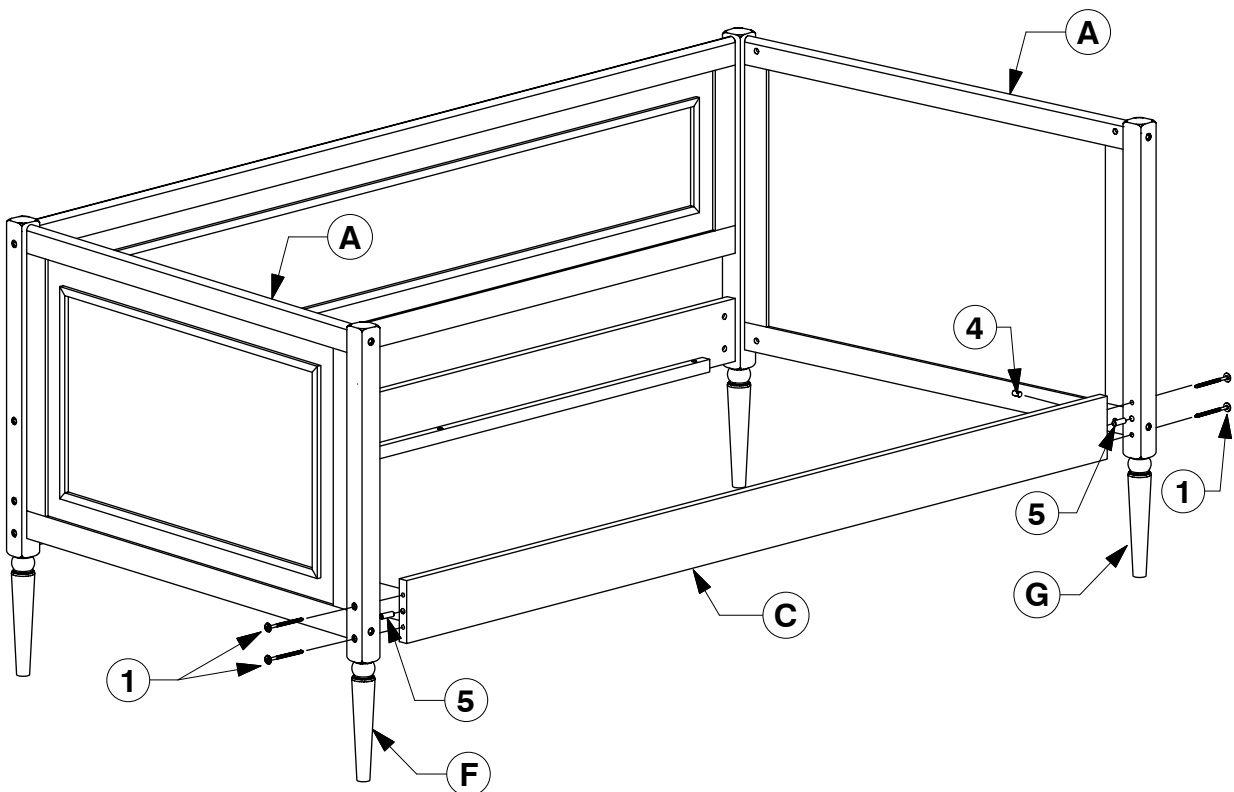
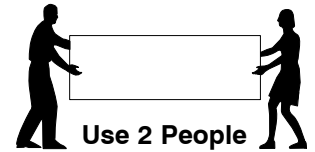

0076 Daybed

Assembly Instructions

WI-1220

- 8** Bolt the Set of Slats (H) between the Side Rail (C).

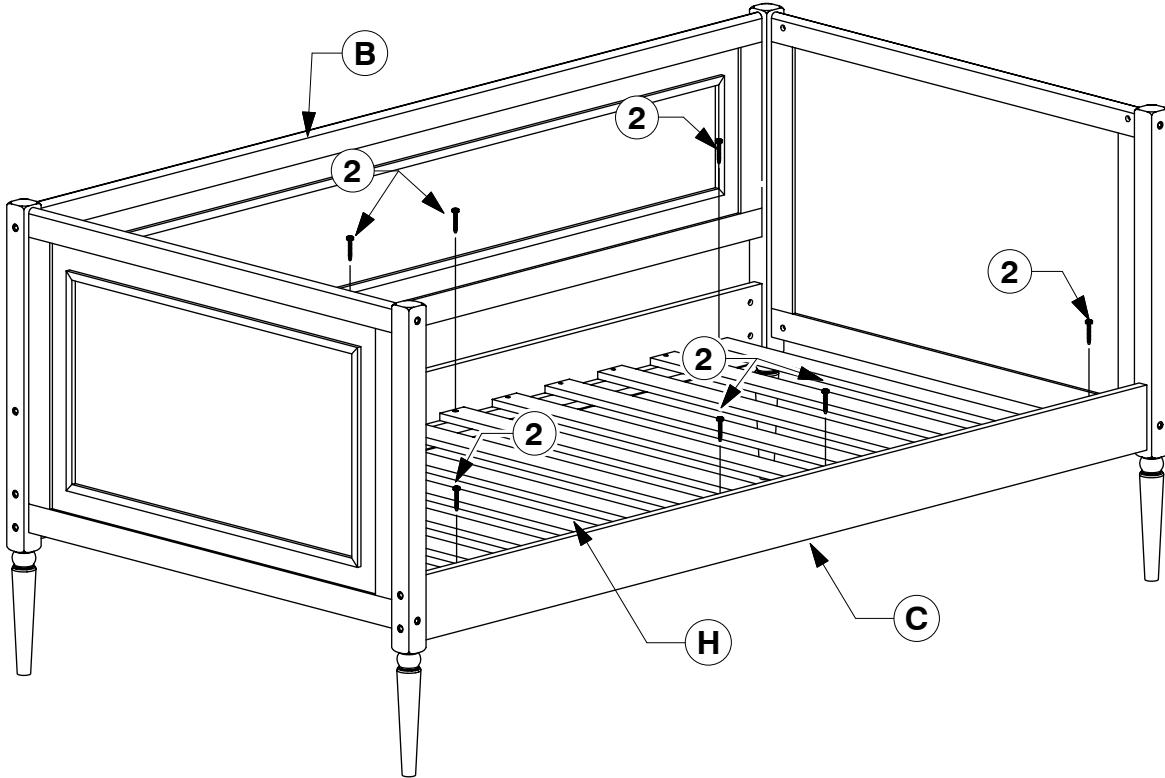

- 9** Screw the Set of Slats (H) between the Side Rail (C).

