





# ASSEMBLY INSTRUCTIONS

## MODEL : DUETO DINING CHAIR

**IMPORTANT NOTE :**

- \* PLACE ALL WOODEN PARTS ON A CLEAN AND SMOOTH SURFACE SUCH AS A RUG OR CARPET TO AVOID THE PARTS FROM BEING SCRATCHED.
- \* BEFORE YOU BEGIN, KINDLY FOLLOW THE ASSEMBLY INSTRUCTIONS STEP BY STEP.
- \* DO NOT TIGHTEN ALL SCREWS UNTIL THE CHAIR IS FULLY SET-UP.

HARDWARE LIST			PART LIST		
A	JCBC M6 x 25mm + S/W M6 + F/W M6 x 13mm 	4PCS	1	RIGHT SIDE FRAME	1PC
B	JCBC M6 x 50mm + S/W M6 + F/W M6 x 13mm 	4PCS	2	LEFT SIDE FRAME	1PC
C	ALLEN KEY M4 (Ball Shape) 	1PC	3	FRONT STRETCHER	1PC
D	L BRACKET 	4PCS	4	BACK STRETCHER	1PC
E	CSK SCREW M3.5 x 12mm 	8PCS	5	TOP REST	1PC
			6	CUSHION SEAT	1PC

### CAUTIONS :

(1) DO NOT FULLY-TIGHTEN THE NUT OR NUT BOLTS INITIALLY UNTIL ALL NUTS OR BOLT IS READY ASSEMBLED.

(TO AVOID CAUSING DAMAGES TO THE THREAD, DO NOT OVER-TIGHTEN THE NUTS OR BOLTS.)

(2) KEEP ALL HARDWARE PART OUT OF REACH OF CHILDREN.

### STEP 1

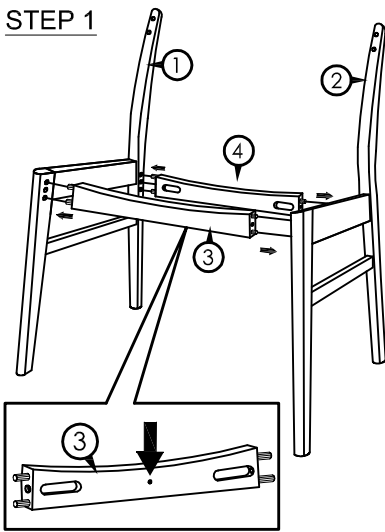

Front Stretcher (3) has a small hole for identification.

### STEP 2

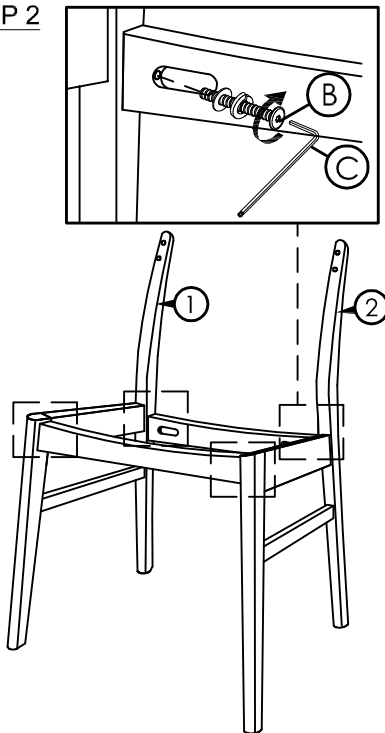

### STEP 3

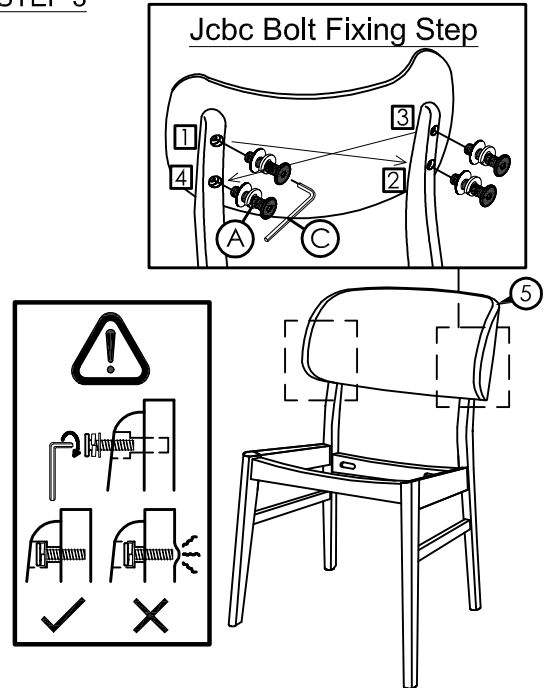

### STEP 4

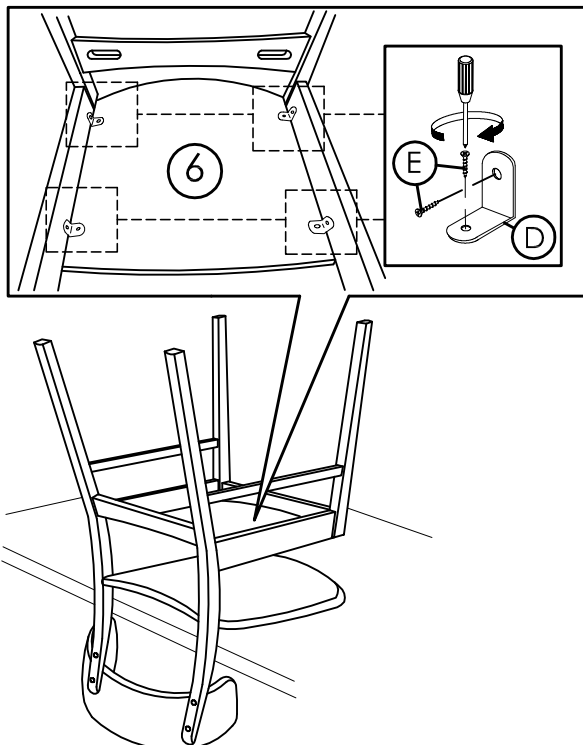

### STEP 5

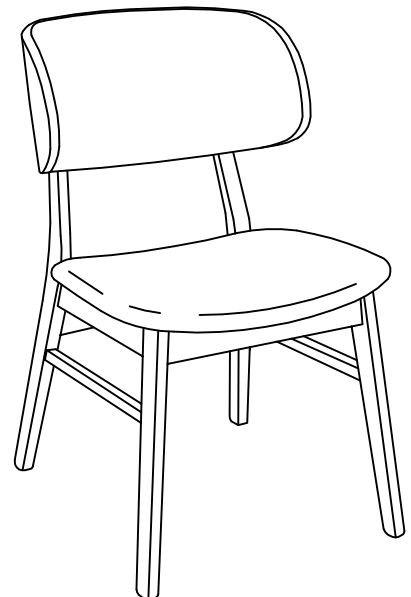

COMPLETED CHAIR ASSEMBLY.