















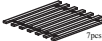





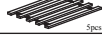





ASSEMBLY INSTRUCTION

BECKER F/T DAYBED
BECKER Q/T DAYBED

NO	PART LIST	QTY
1	 BACK REST	1PC
2	 SIDE PANEL (L)	1PC
3	 SIDE PANEL (R)	1PC
4	 FRONT SIDE RAIL	1PC
5	 BACK SIDE RAIL	1PC
6	 LEG	4PCS
7	 SLAT	2 SET
8	 CENTER SUPPORT	1PC
9	 SUPPORT LEG	2PCS
10	 TRUNDLE FRONT RAIL	1PC
11	 TRUNDLE BACK RAIL	1PC
12	 TRUNDLE SIDE RAIL	2PCS
13	 TRUNDLE SLAT	2 SET
14	 TRUNDLE SUPPORT	3PCS
15	 CASTOR	6PCS
ITEM	HARDWARE	QTY
A	 JCBB SCREW M8 x 20MM	20PCS
B	 JCBC SCREW M6 x 35MM	4PCS
C	 JCBC SCREW M6 x 50MM	16PCS
D	 SPRING WASHER	16PCS
E	 FLAT WASHER (BIG)	4PCS
F	 FLAT WASHER (SMALL)	12PCS
G	 SCREW M4 x 16MM	24PCS
H	 SCREW M4 x 32MM	22PCS
I	 L - KEY M4 x 100MM	1PC
J	 L - KEY M5 x 65MM	1PC
K	 STOPPER	2PCS

STEP 1

Begin assembly by attaching each Leg (6) to the bottom of the Side Panel (2) & (3) securing with 2 Allen Bolt (B) per panel using L-key (I).

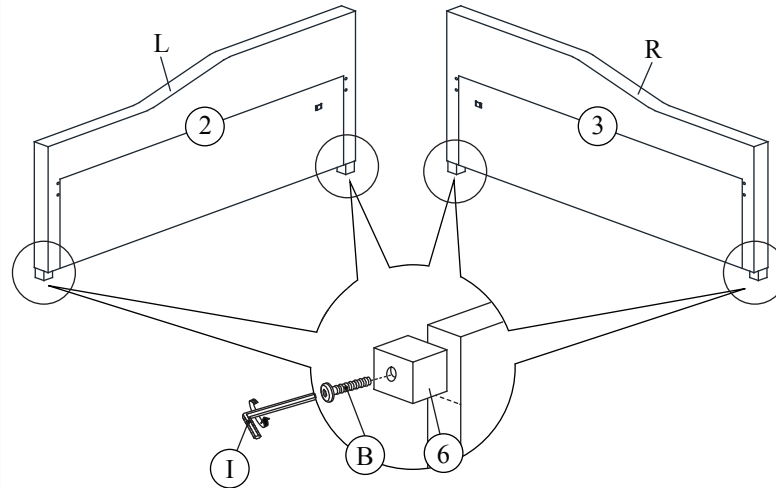

STEP 2

Attach the Front Rail (4) and Back Rail (5) to the Side Panel (2) & (3) by aligning holes and securing with 2 Allen Bolts (A) per each end using L-key (J). (DO NOT FULLY TIGHTEN BOLTS FOR THIS STEP)

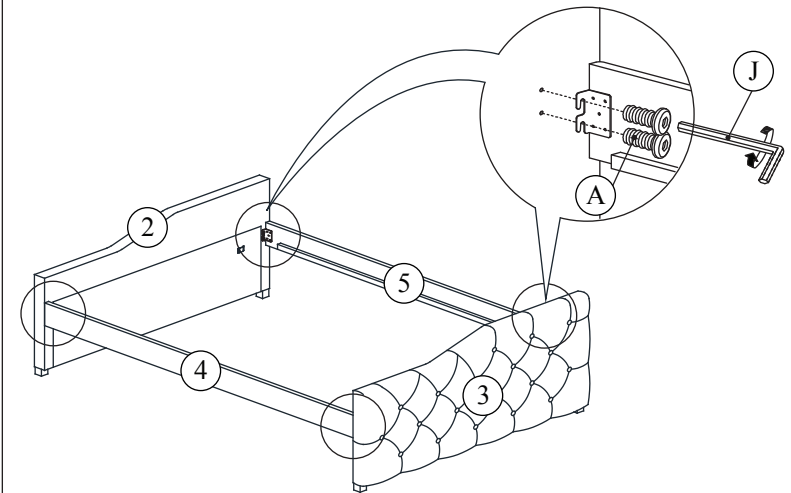

STEP 3

Attach the Back Rest (1) to each Side Panel (2) & (3) by aligning the hole and securing with 2 Allen Bolts (C), 2 Spring Washer (D), 2 Flat Washer (E) per each end using L-key (I) as picture below. (DO NOT FULLY TIGHTEN BOLTS FOR THIS STEP)

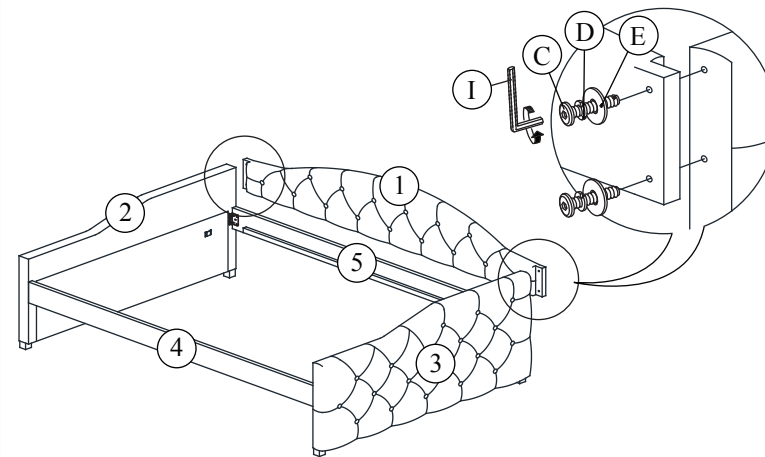

STEP 4

Secure 2 Support Leg (9) to the Center Support (8) as shown on step 4.1. Tighten the Support Leg (9) clockwise until secure. Insert the pre-set metal on Center Support (8) to the metal bracket on each side of Side Panel (2) & (3) as step 4.2. Then securing the metal bracket as shown in step 4.3 with 1 Screw (H) each side using Phillips Head Screwdriver (NOT INCLUDED)

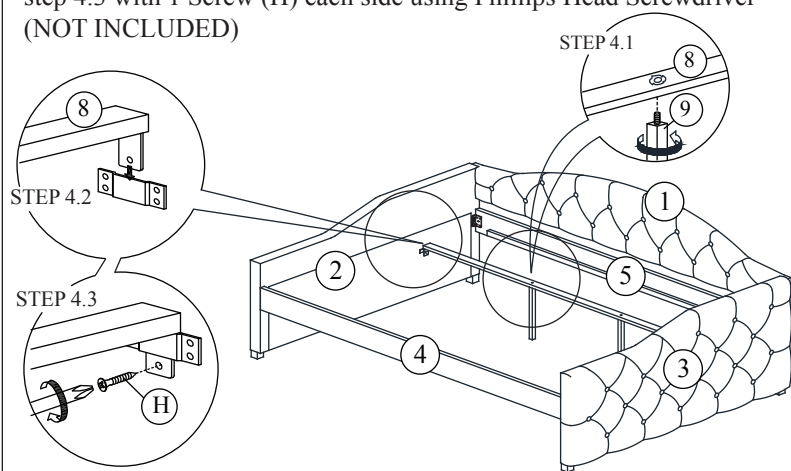

Please do not tighten the hardware until the entire assembly is completed.

ASSEMBLY INSTRUCTION

STEP 5

Tighten All Bolts from step 1 to step 4 by using L-key (I) & (J) that has been provided. Attached Slat (7) to Front Side Rail (4) & Back Side Rail (5) by unrolling and securing with 6 Screw (H), per set using Phillips Head Screwdriver. Securing Slat (7) to Back Side Rail (5) with 2 Screw (H) as step 5.1. Following by step 5.2, using 1 Screw (F) to secure Slat (7) to Front Side Rail (4). Repeat the same step to attach another set of Slat (7).

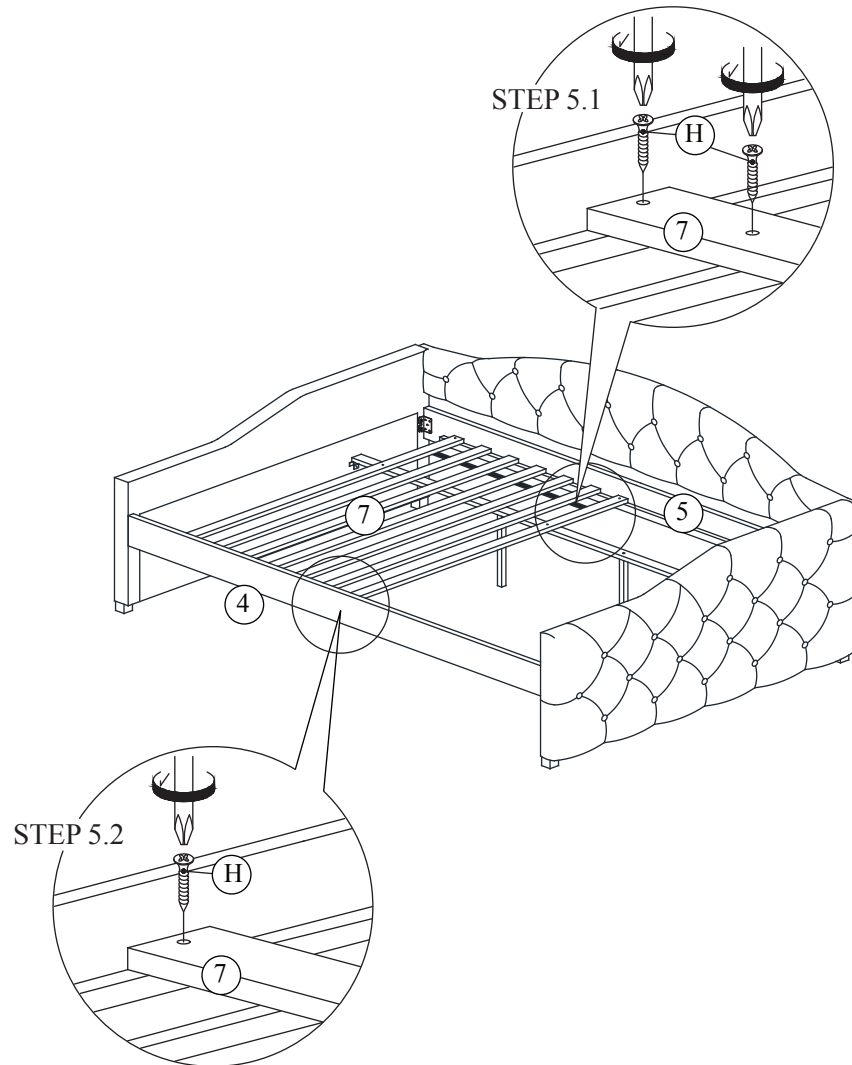

STEP 6

Attach the Stopper (K) to the front side of Side Panel (2) & (3) each side by securing with 2 Allen Bolt (A) using L-key (J) to avoid trundle pull out.

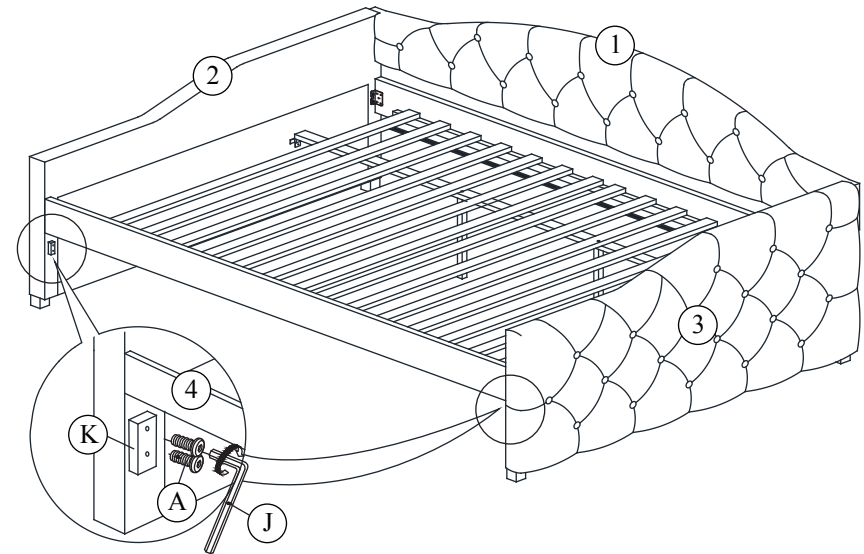

STEP 7

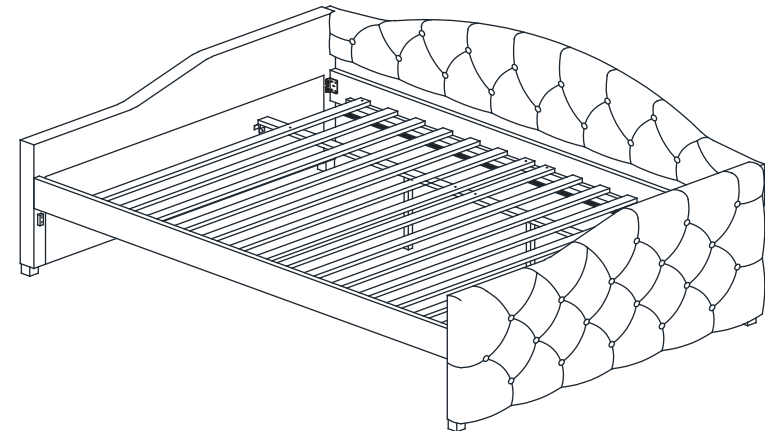

ASSEMBLY
COMPLETE

Please do not tighten the hardware until the entire assembly is completed.

ASSEMBLY INSTRUCTION

STEP 8

Begin with attaching Trundle Side Rail (12) to Front Rail (10) & Back Rail (11) using 2 Bolts (A) per corner. Tighten bolts with Allen Key (J) provided.

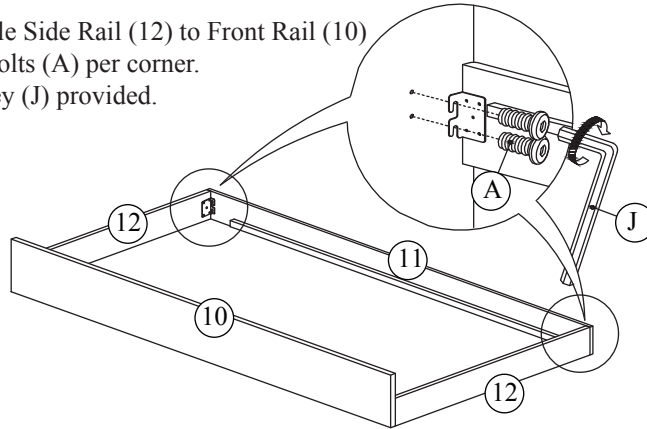

STEP 9

Attaching 2 Castors (15) to the bottom of Trundle Support (14) according to the pre-mark line. Securing with 4 Screws (G) per each Castor (15) using Phillips screwdriver (NOT PROVIDED).

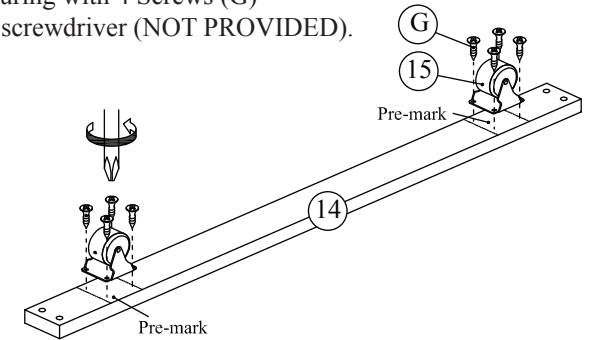

STEP 10

Attach Trundle Support (14) to Front Rail (10) & Back Rail (11) using 2 Bolts (C), 2 Spring Washers (D) and 2 Flat Washer (F) on each end of each Slat Support (14). Tighten bolts with Allen Key (I).

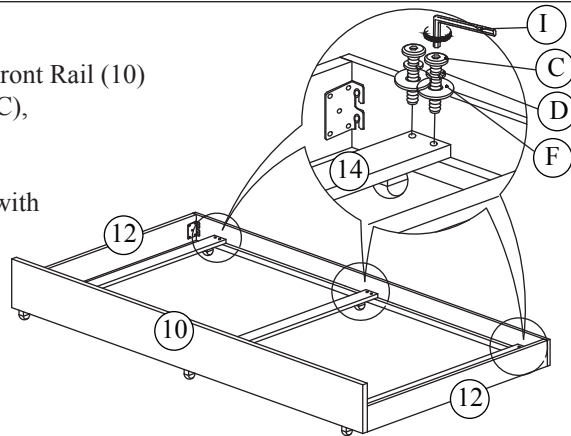

STEP 11

Attach Trundle Slat (13) to Front Rail (10) & Back Rail (11) using 4 Screws (H) per set. Tighten screws with Phillips screwdriver (NOY INCLUDED)

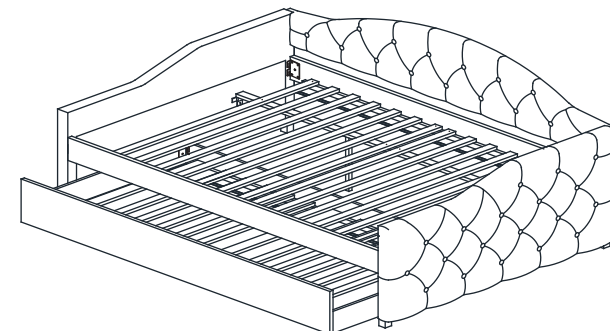
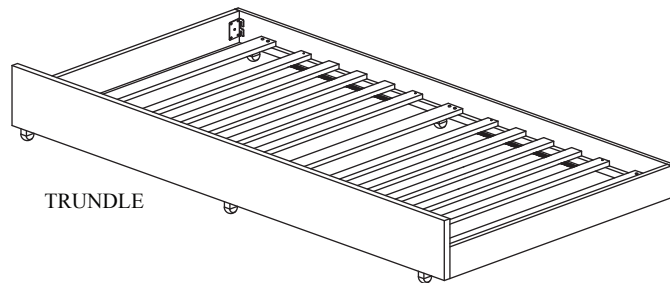
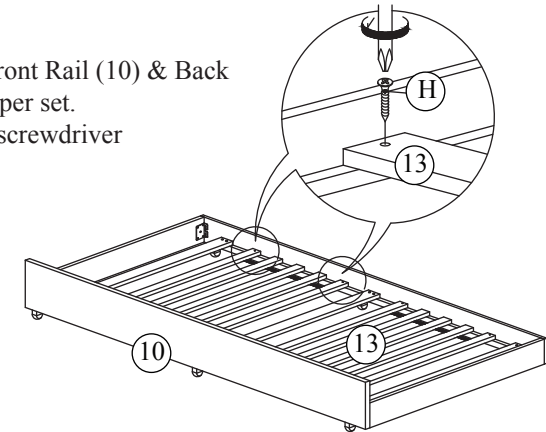

FULL SET

ASSEMBLY COMPLETE

Please do not tighten the hardware until the entire assembly is completed.