











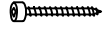

# Assembly Instructions

MPC 8022

Part List		QTY	Part List		QTY
1	Top Panel	1	14	Back Panel	1
2	Left Side Panel	1	15	Legs	4
3	Right Side Panel	1	16	Center Support Legs	1
4	Top Back Panel	1	17	Back Panel	1
5	Top Front Panel	1			
6	Middle Panel	1			
7	Big Shelf Panel	3			
8	Small Shelf Panel	4			
9	Inner Bottom Panel	1			
10	Bottom Panel	1			
11	Door Left	1			
12	Middle Door	1			
13	Door Right	1			

Hardware		QTY
A	Allen Key M4 	1
B	Dowel 	18
C	JCBC W Screw M6x40 	6
D	Mini Fix Bolt 	17
E	Mini Fix Housing 	17
F	Mini Fix Cap 	17
G	CSK Screw M3.5x16mm 	62
H	Shelf Support Metal 	28
I	Handle 	3
J	Handle screw 20mm 	6
K	7/8 Hinge 	5
L	Nail 	60
M	2/8 Hinge 	2

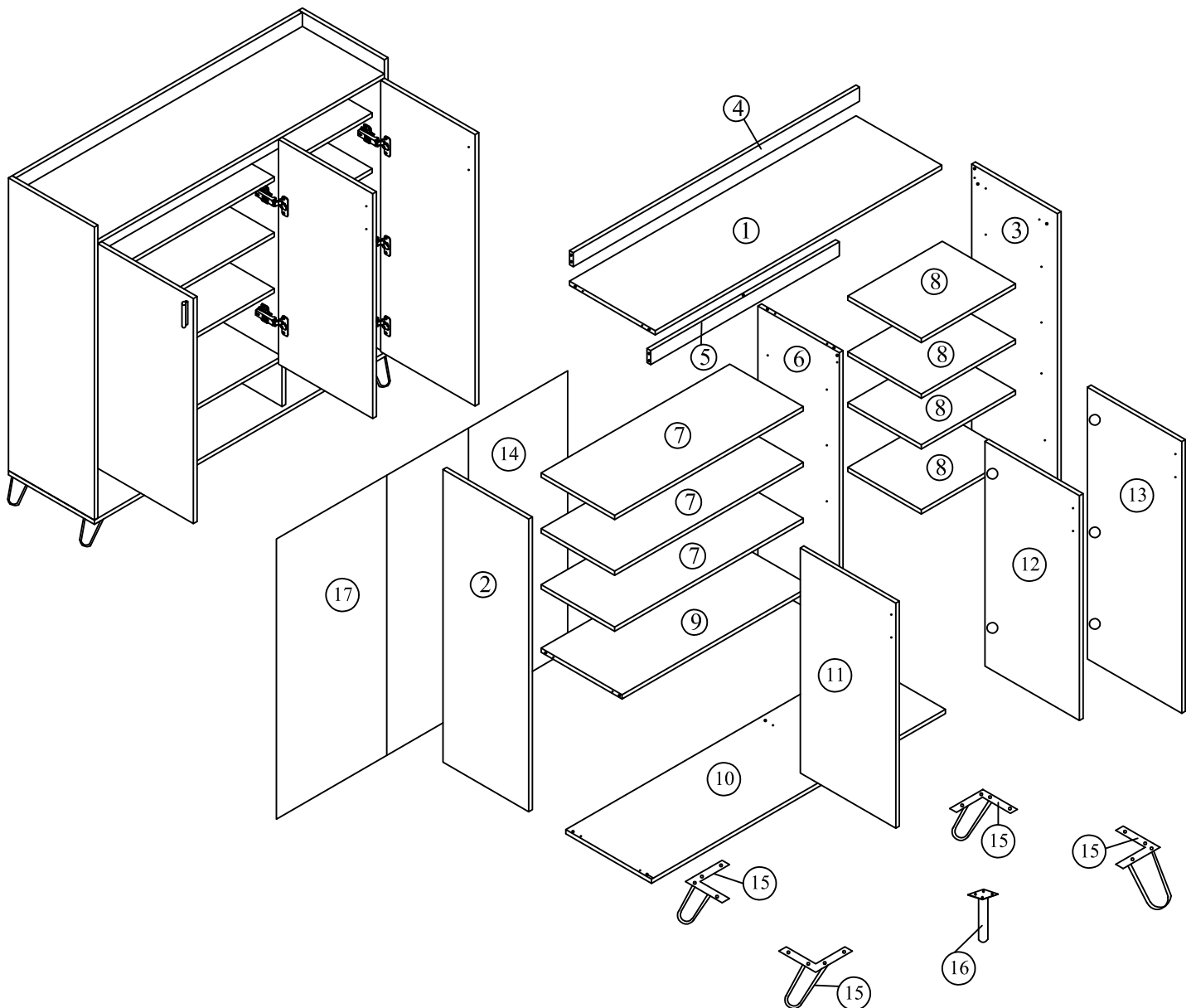

# Step 1

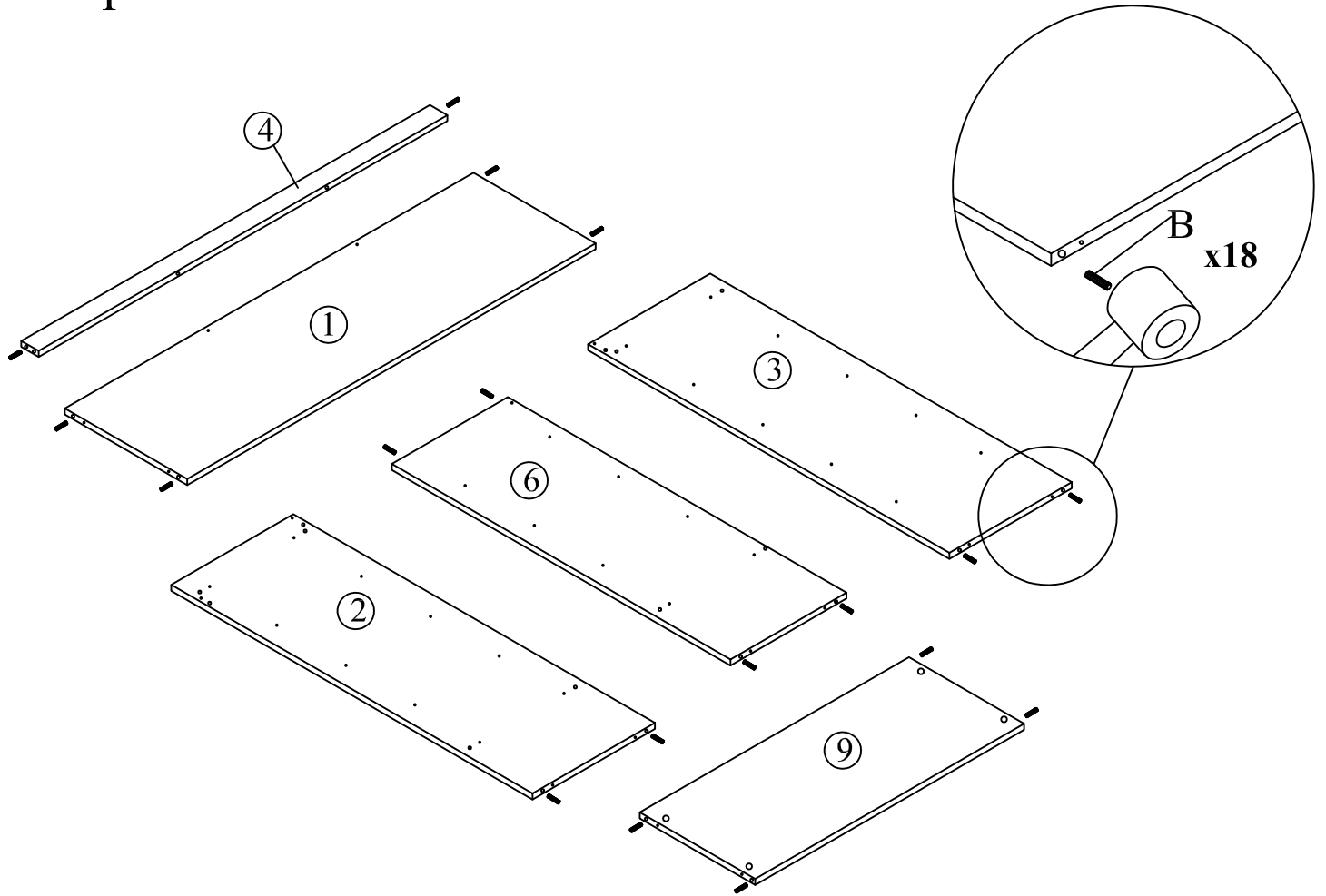

# Step 2

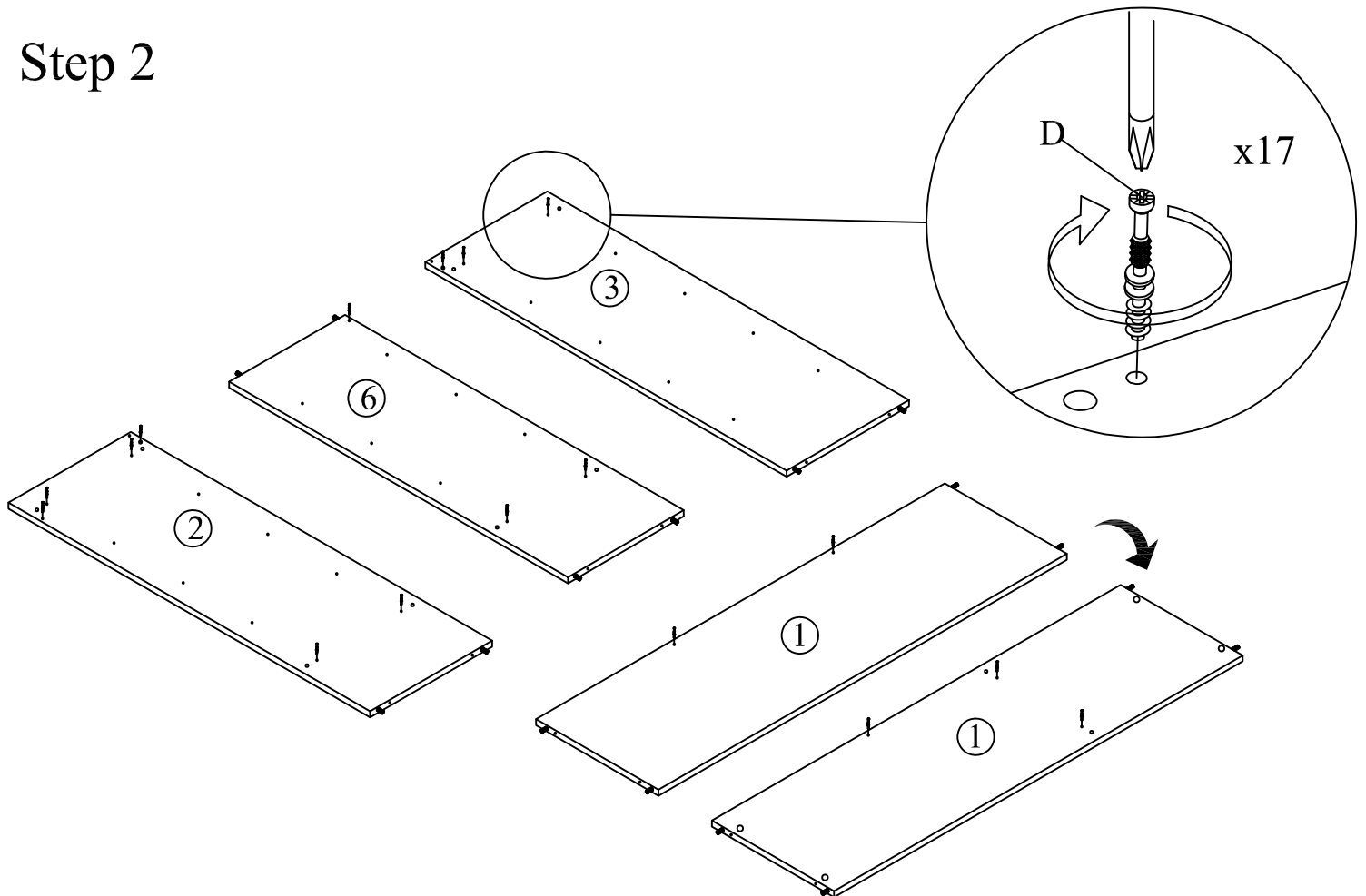

# Step 3

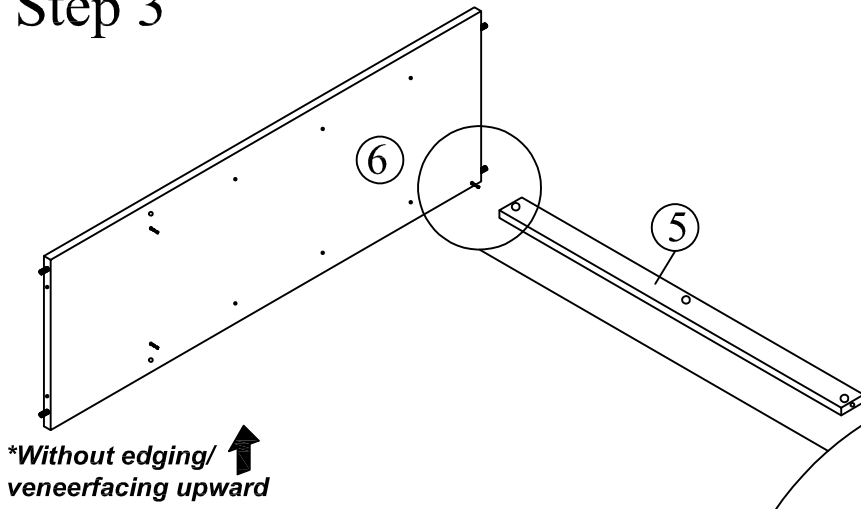

This is how a mini fix works...

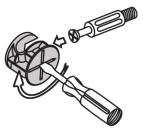

The head of the mini fix housing goes into the open mouth of the mini fix bolt. You then turn the mini fix housing so it tightens over the mini fix bolt.

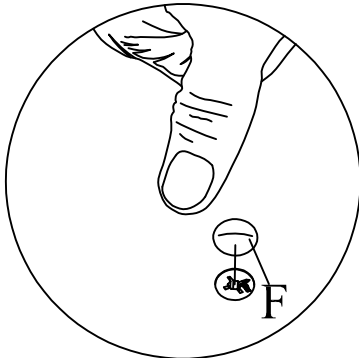

**\*Attach Minifix Cap as shown.**

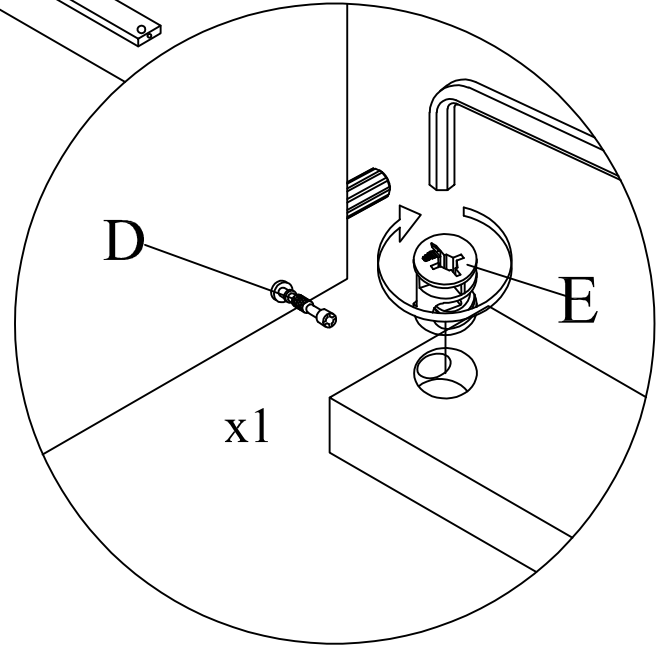

# Step 4

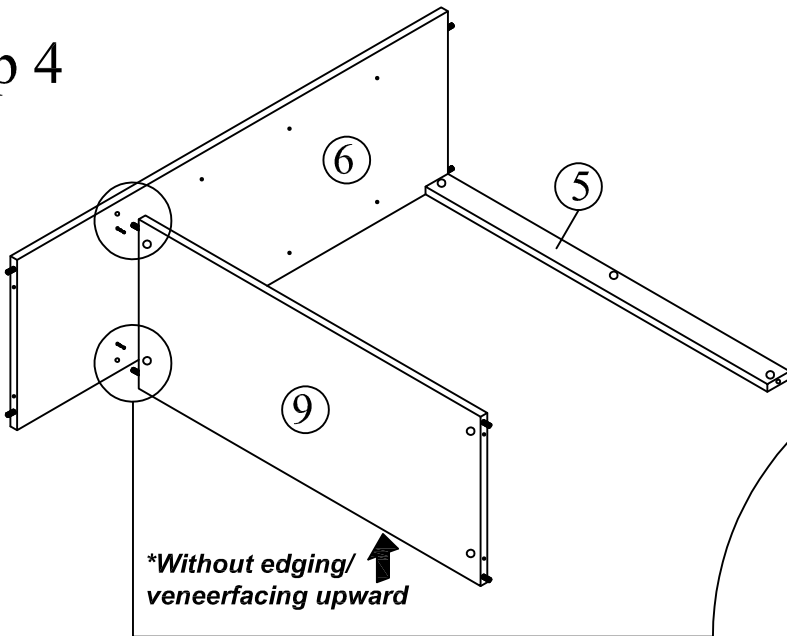

This is how a mini fix works...

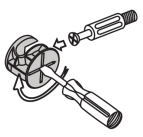

The head of the mini fix housing goes into the open mouth of the mini fix bolt. You then turn the mini fix housing so it tightens over the mini fix bolt.

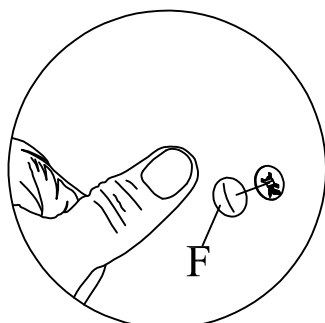

**\*Attach Minifix Cap as shown.**

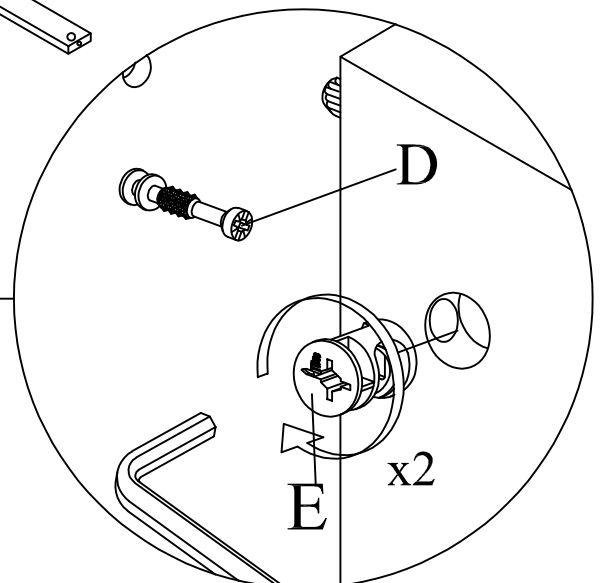

# Step 5

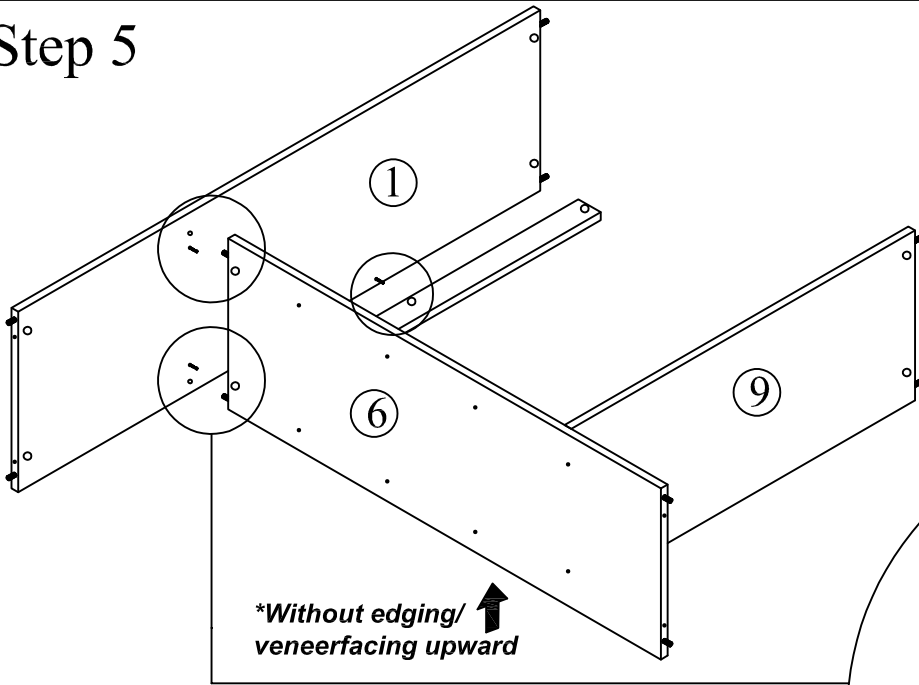

This is how a mini fix works...  
The head of the mini fix housing goes into the open mouth of the mini fix bolt. You then turn the mini fix housing so it tightens over the mini fix bolt.

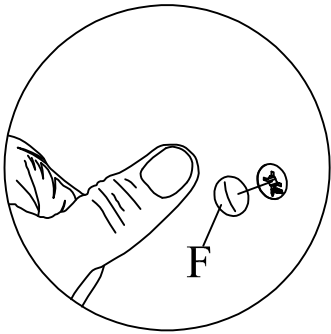
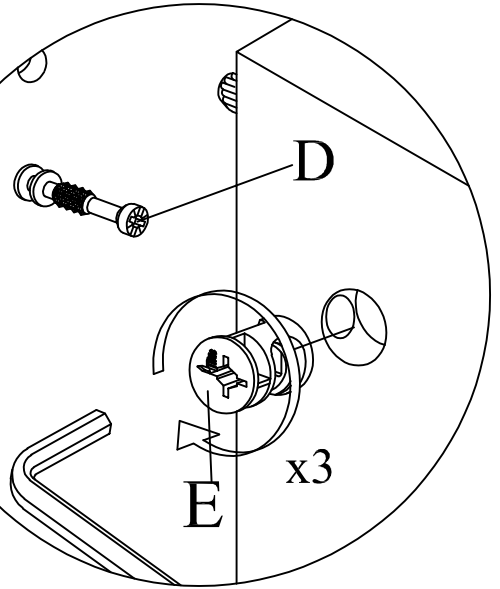

**\*Attach Minifix Cap as shown.**

# Step 6

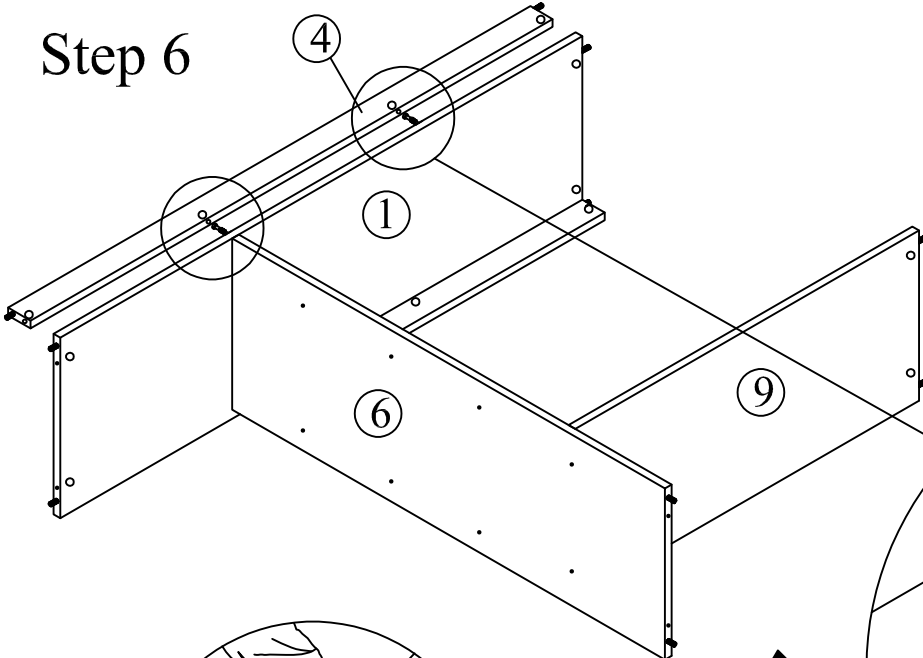

This is how a mini fix works...  
The head of the mini fix housing goes into the open mouth of the mini fix bolt. You then turn the mini fix housing so it tightens over the mini fix bolt.

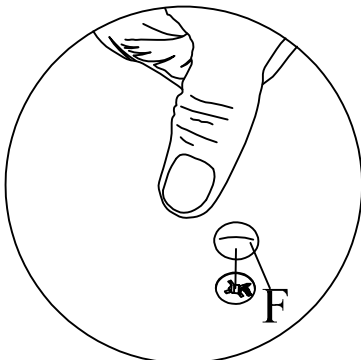
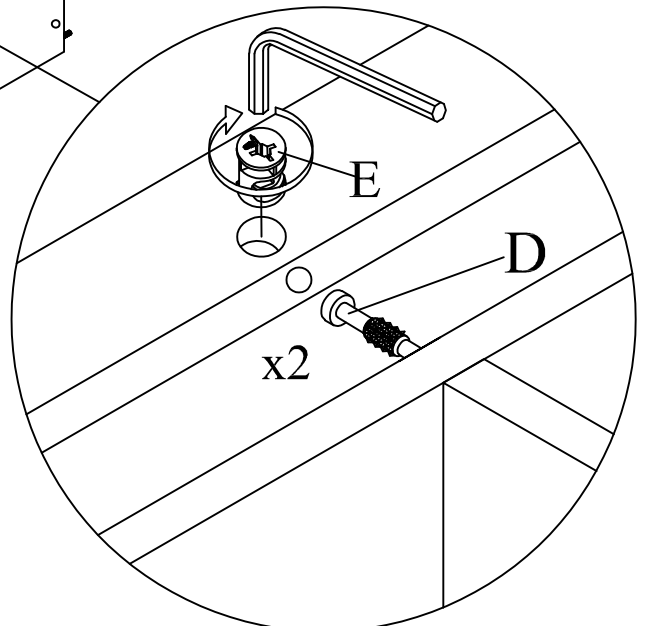

**\*Attach Minifix Cap as shown.**

# Step 7

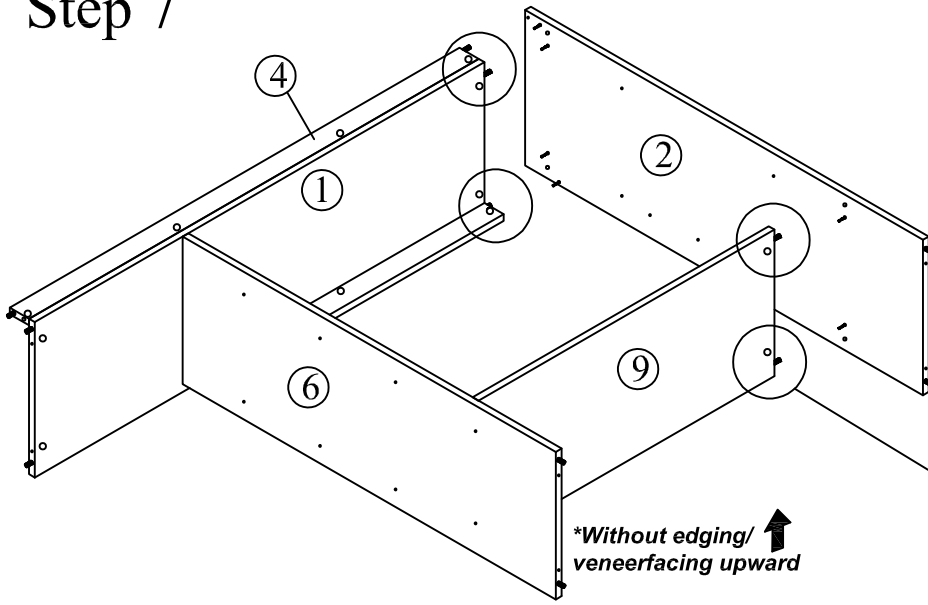

*\*Without edging/ ↑  
veneering upward*

This is how a mini fix works...

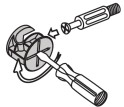

The head of the mini fix housing goes into the open mouth of the mini fix bolt. You then turn the mini fix housing so it tightens over the mini fix bolt.

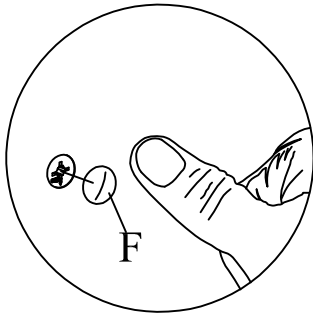

*\*Attach Minifix Cap as shown.*

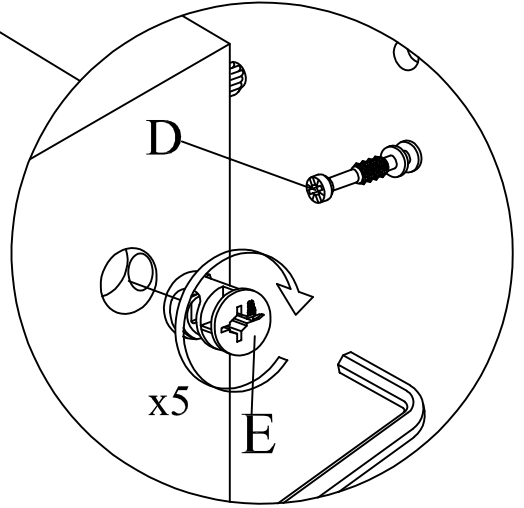

# Step 8

This is how a mini fix works...

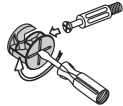

The head of the mini fix housing goes into the open mouth of the mini fix bolt. You then turn the mini fix housing so it tightens over the mini fix bolt.

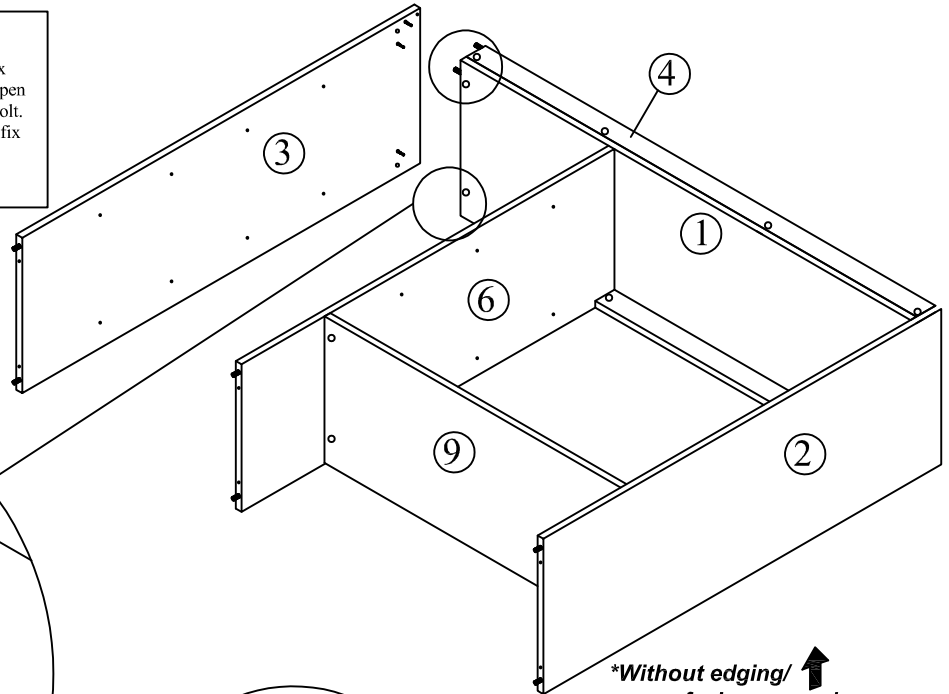

*\*Without edging/ ↑  
veneering upward*

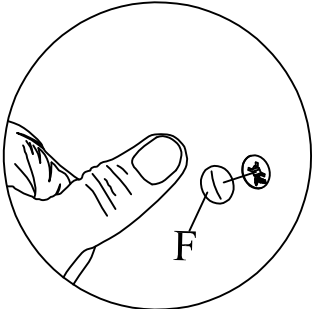
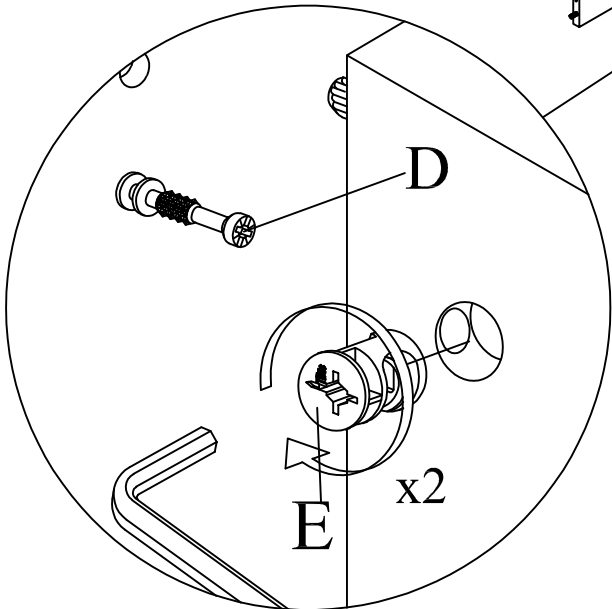

*\*Attach Minifix Cap as shown.*

# Step 9

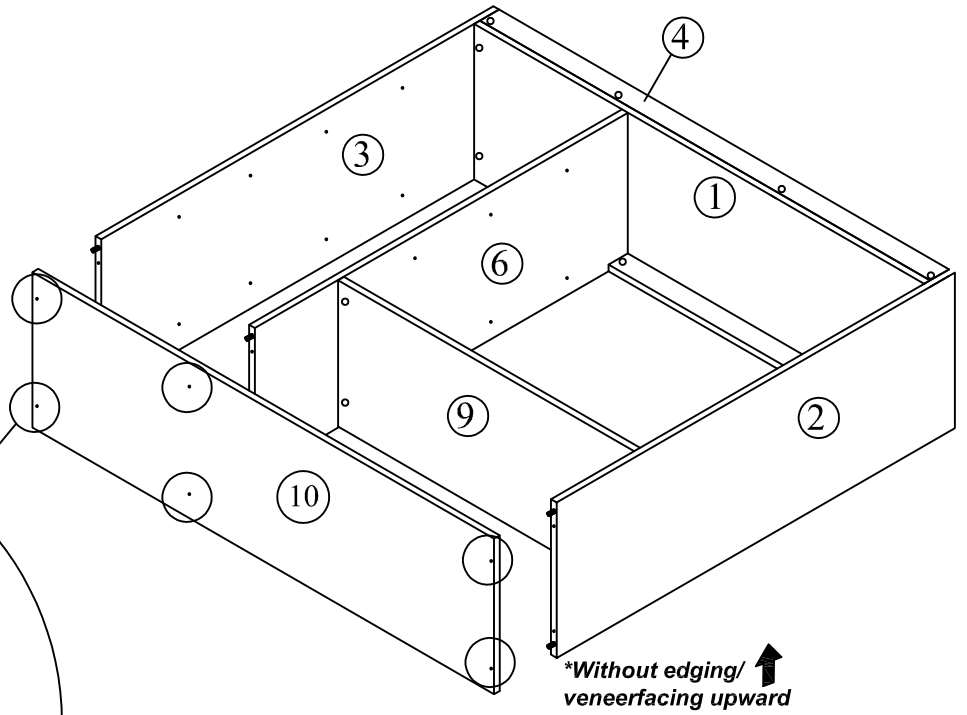
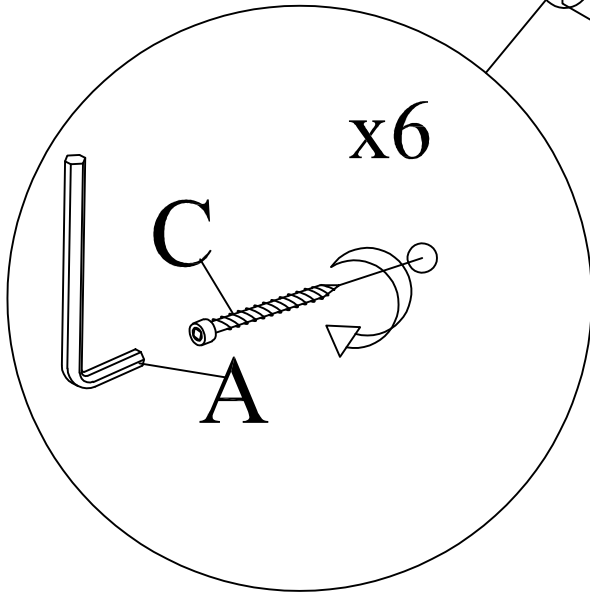

# Step 10

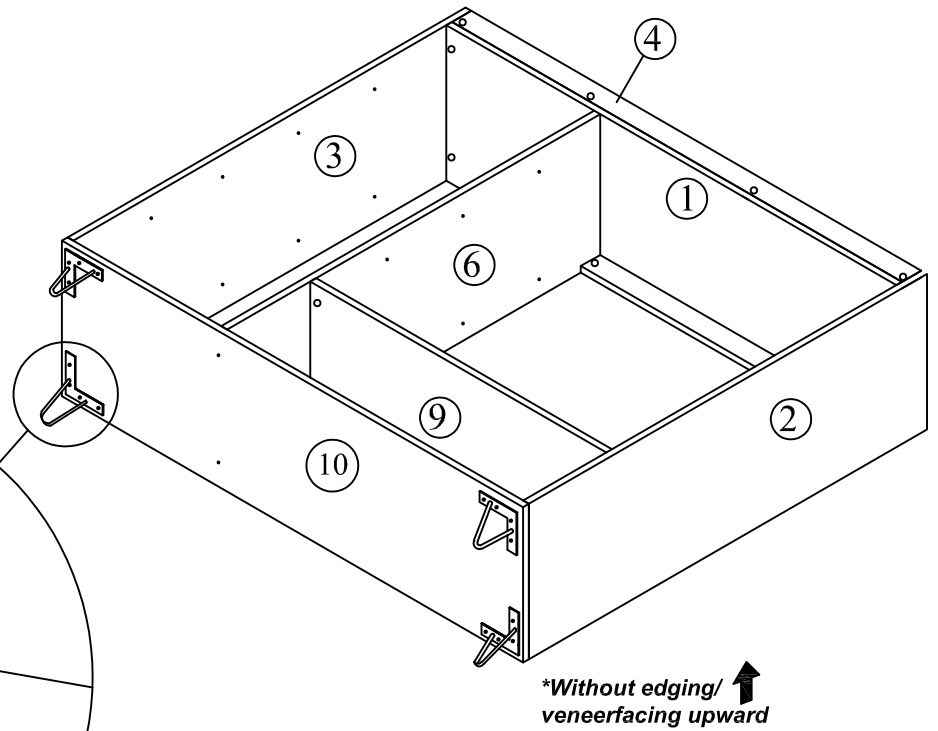
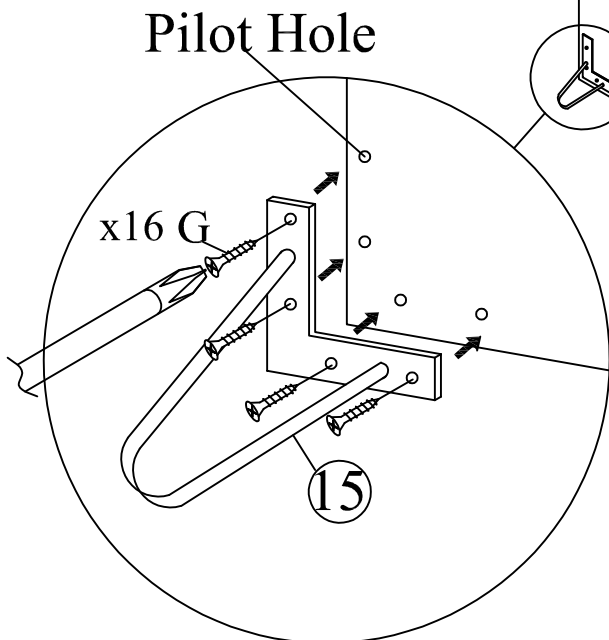

# Step 11

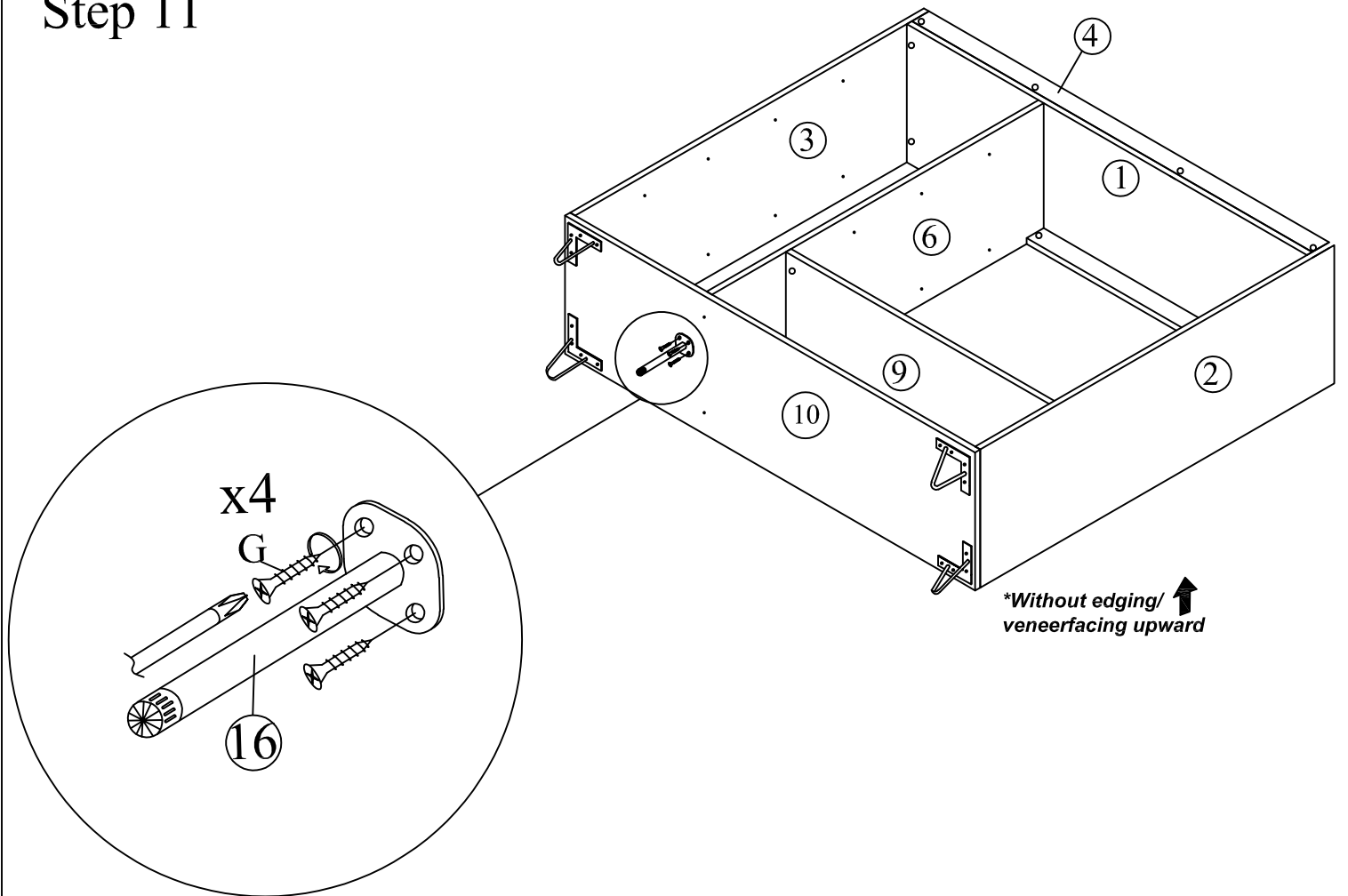

# Step 12

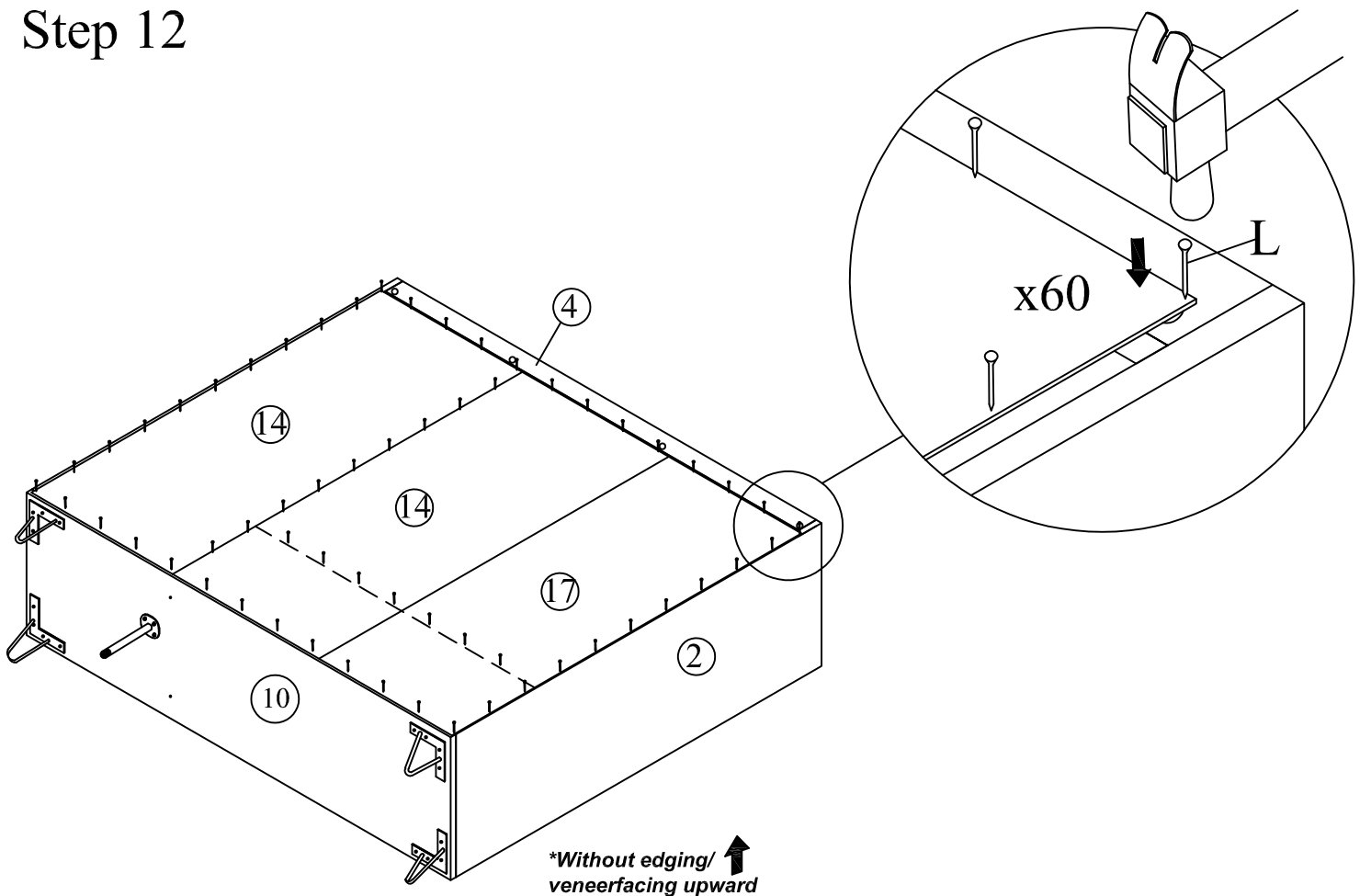

# Step 13

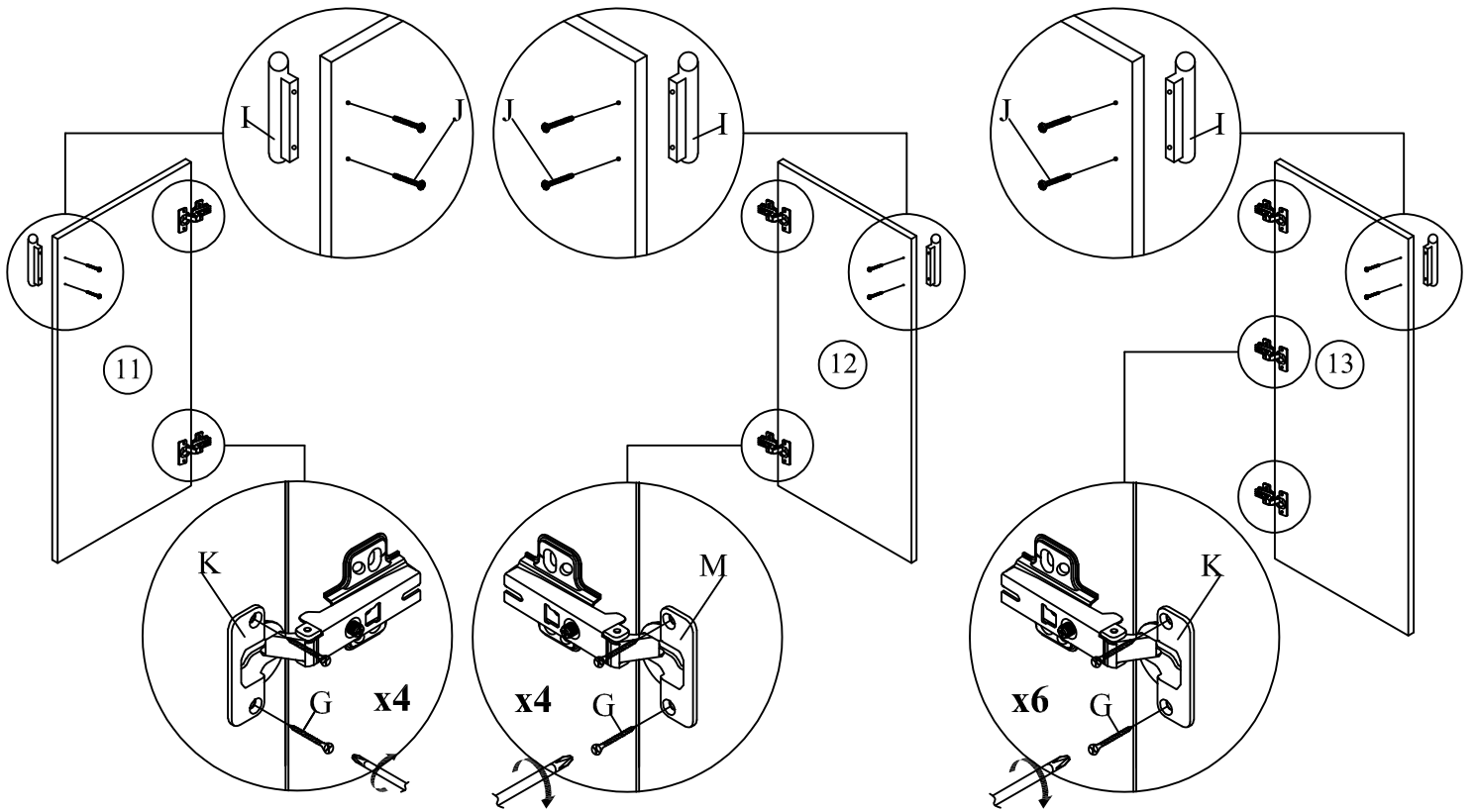

# Step 14

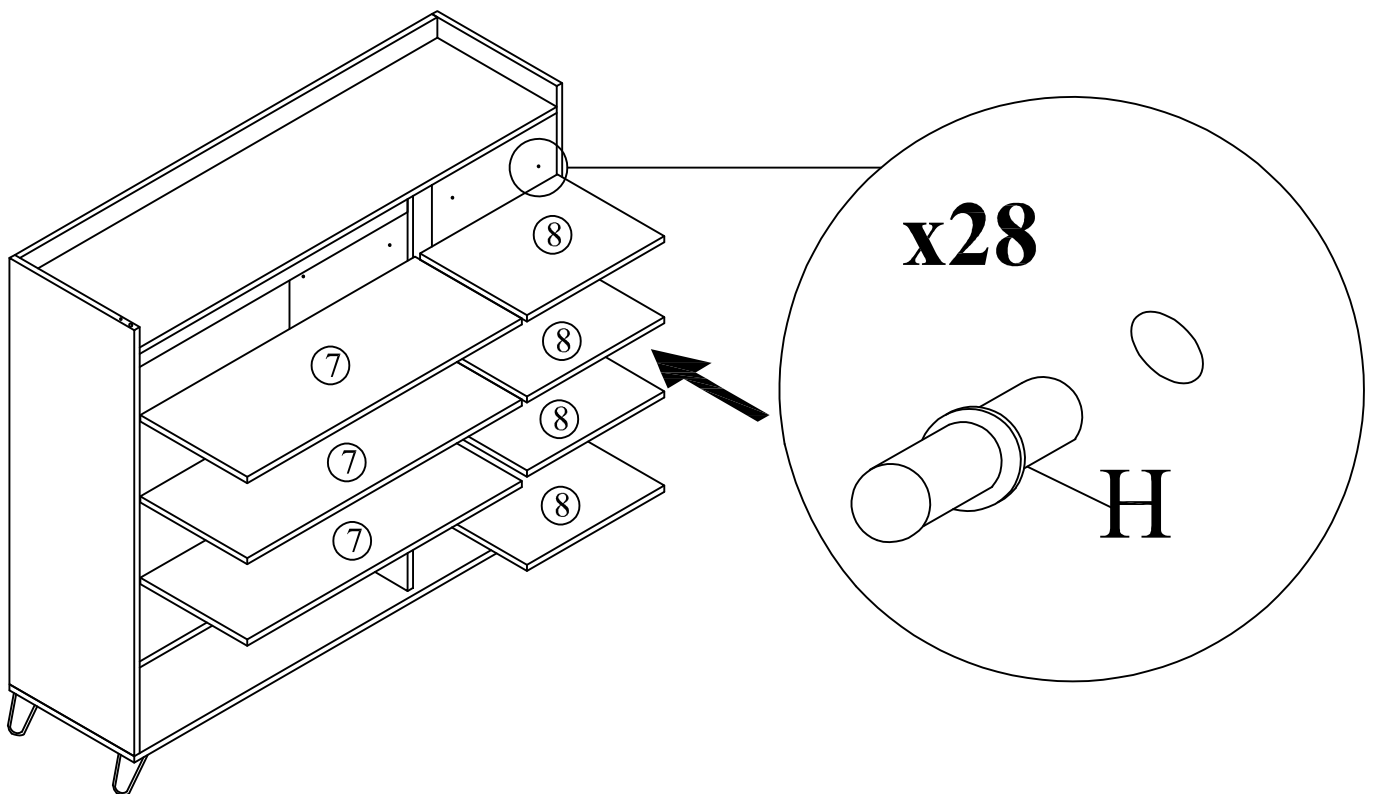



# Step 15

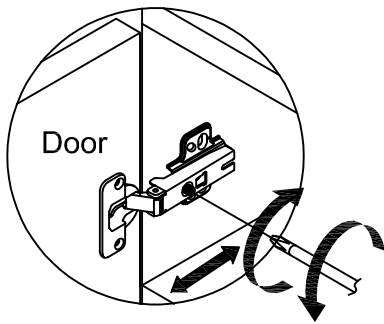
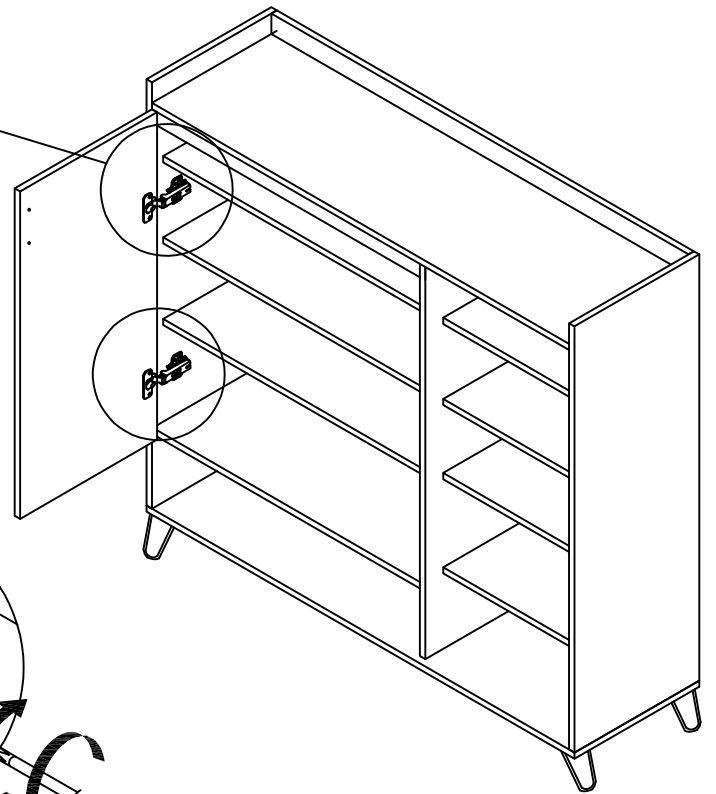
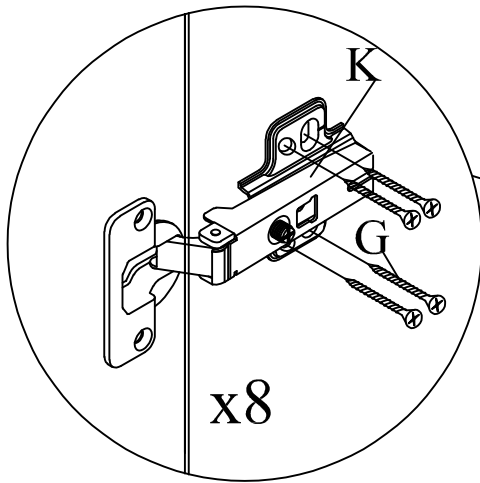

Front to Front Adjustment

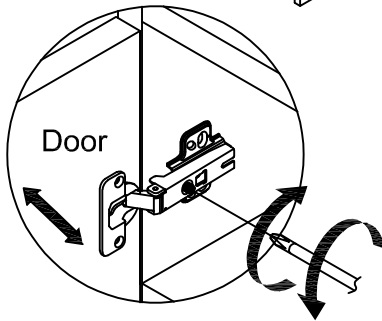

Lateral Adjustment

# Step 16

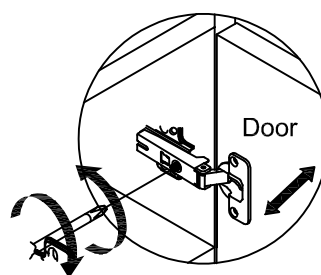
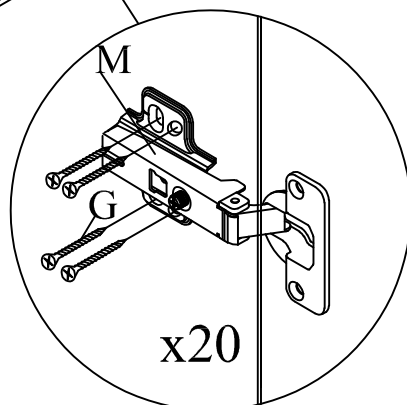
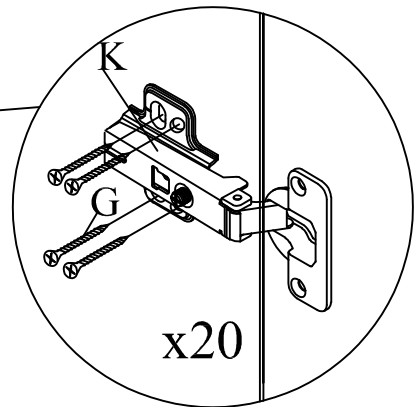
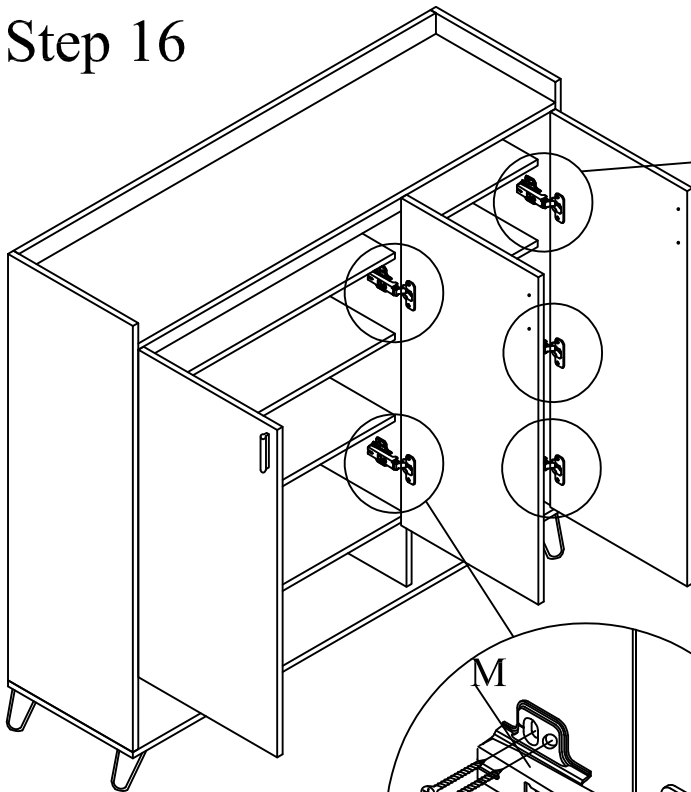

Lateral Adjustment

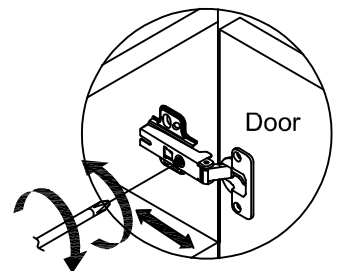

Front to Front Adjustment

Anti -  
Tipping

(A)



CSK Screw  
M3.5x16mm  
1PC

(B)

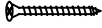

CSK Screw  
M4x50mm  
1PC

(C)



L BRACKET  
2PCS

(D)



CABLE TIE  
1PC

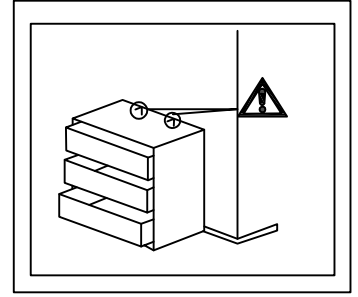
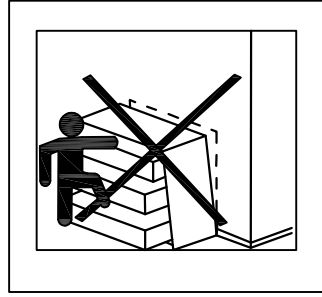

BACK VIEW

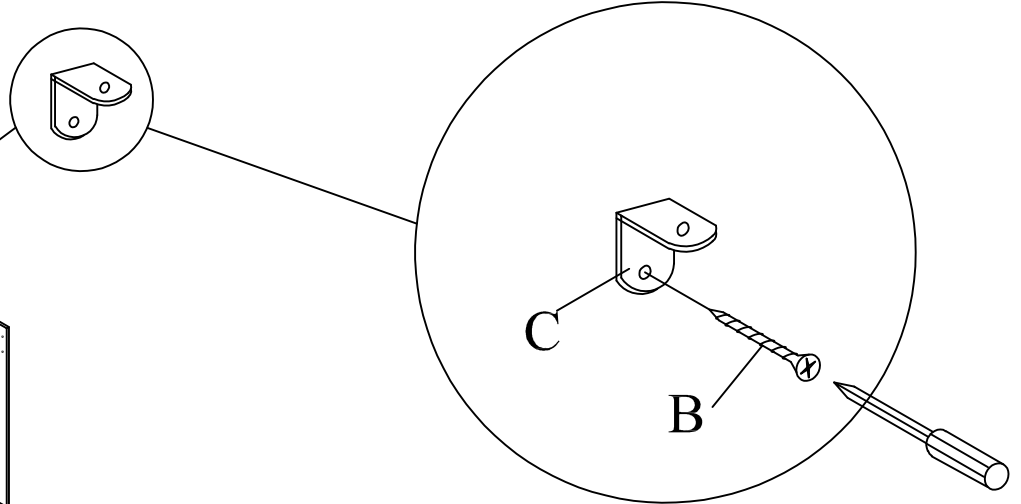
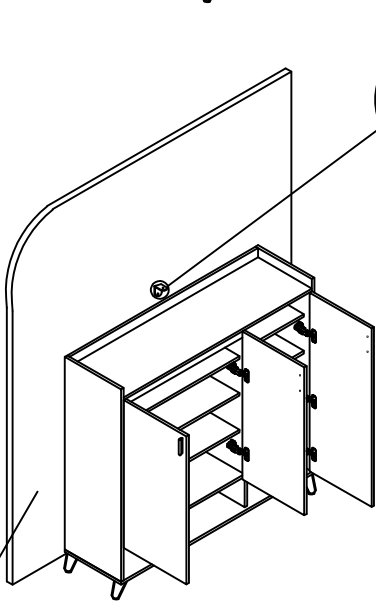
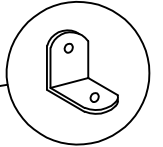
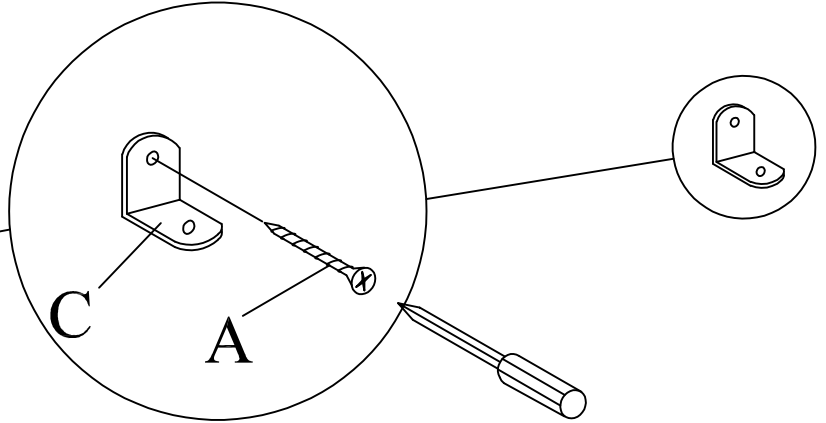
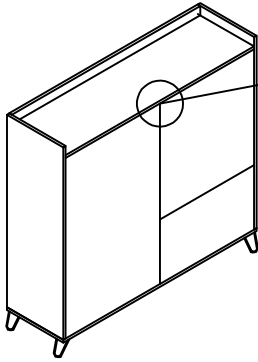

WALL

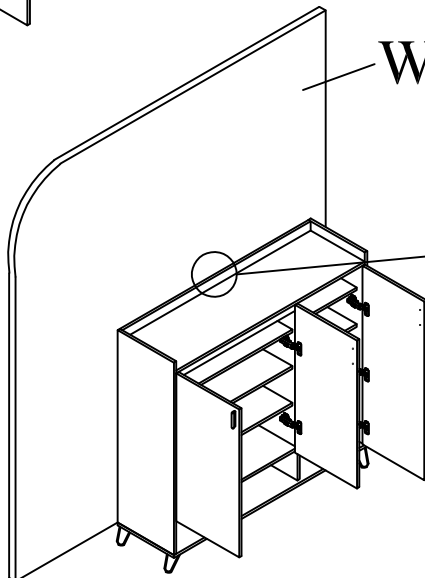

WALL

