

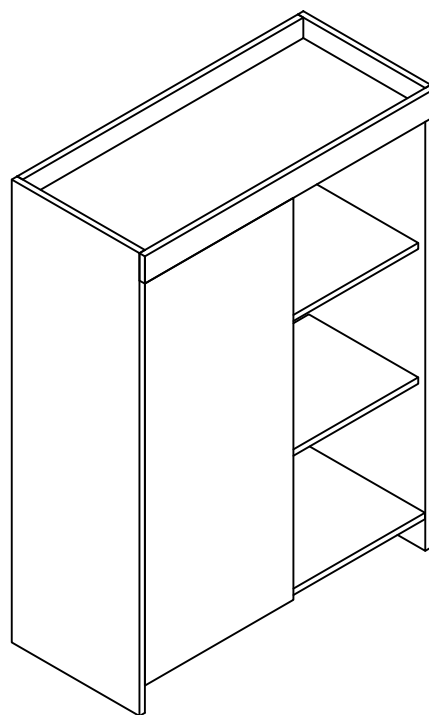











Assembly Instructions

Model: MPC 8015

Part List		QTY
1	Top Panel	1
2	Left Side Panel	1
3	Right Side Panel	1
4	Back Top Panel	1
5	Front Top Panel	1
6	Middle Panel	1
7	Shelf	4
8	Bottom Panel	1
9	Door Panel	1
10	Support Leg Panel	1
11	Left Back Panel (Hole)	1
12	Right Back Panel	1



Hardware		QTY
A	Allen Key M4 	1
B	Dowel 	16
C	Mini Fix Bolt 	20
D	Mini Fix Housing 	20
E	Mini Fix Cap 	20
F	CSK Screw M4x16mm 	32
G	Hinges 	2
H	L Bracket 	8
I	JCBC W Screw M6x40 	2
J	White Nail 	6
K	Shelf Support Metal 	16
L	Stud 	4

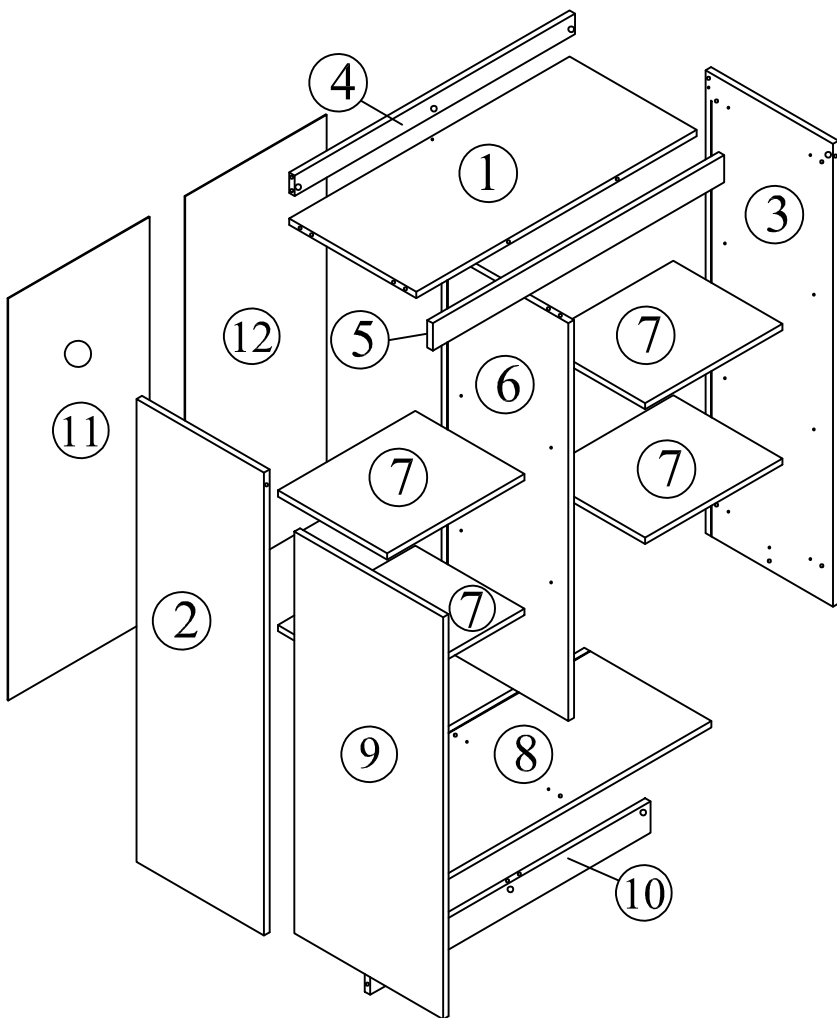

Step 1

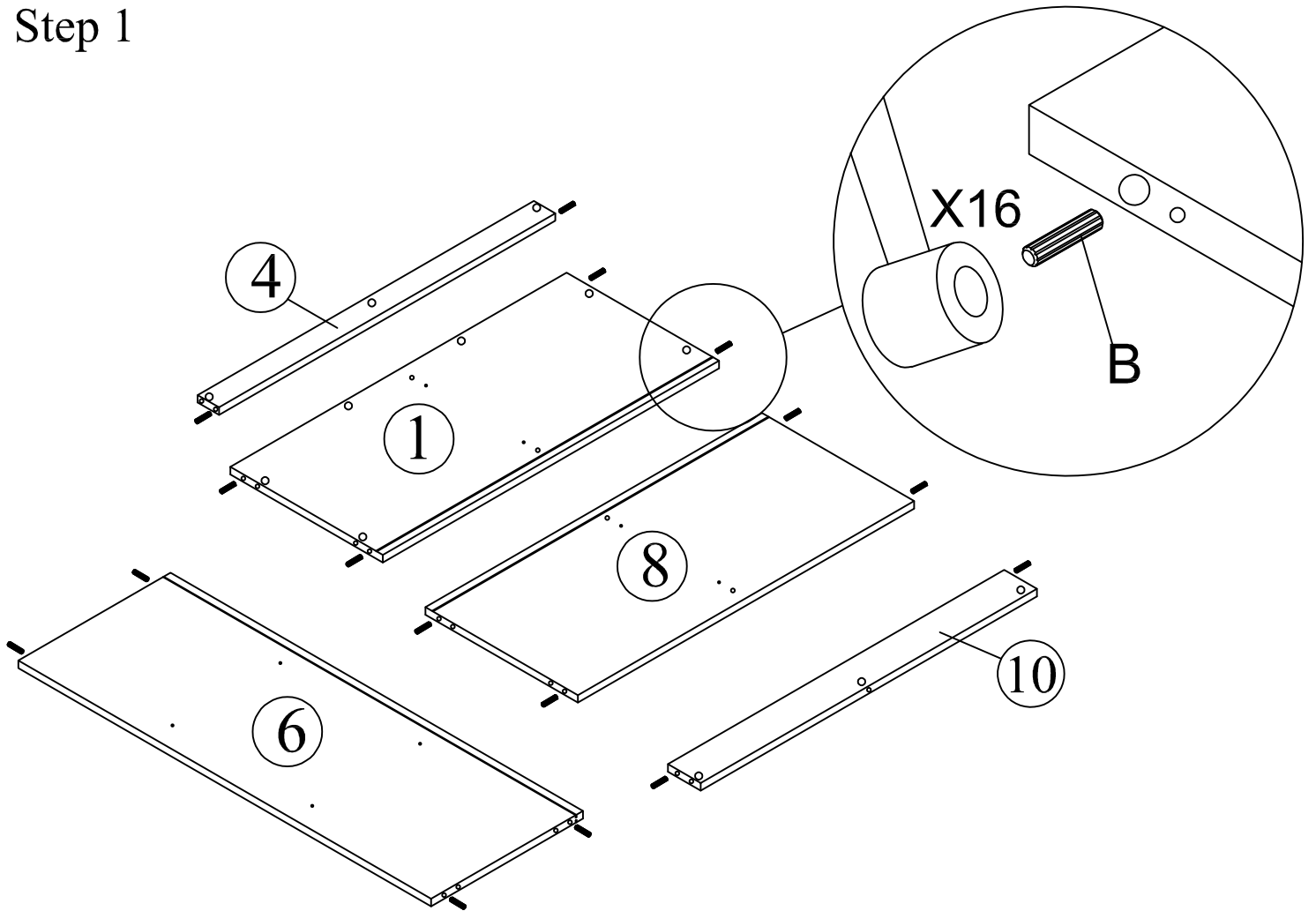

Step 2

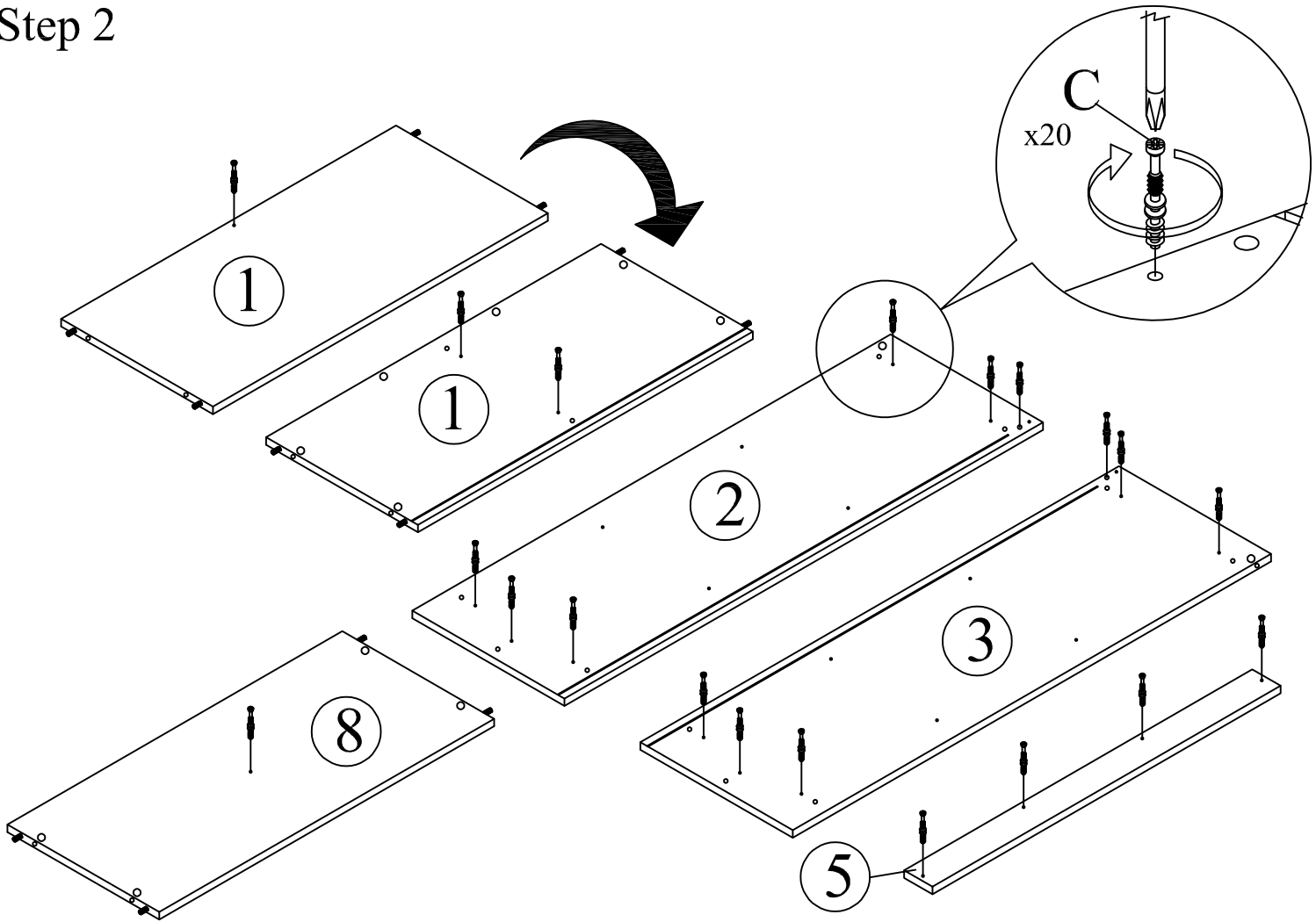

Step 3

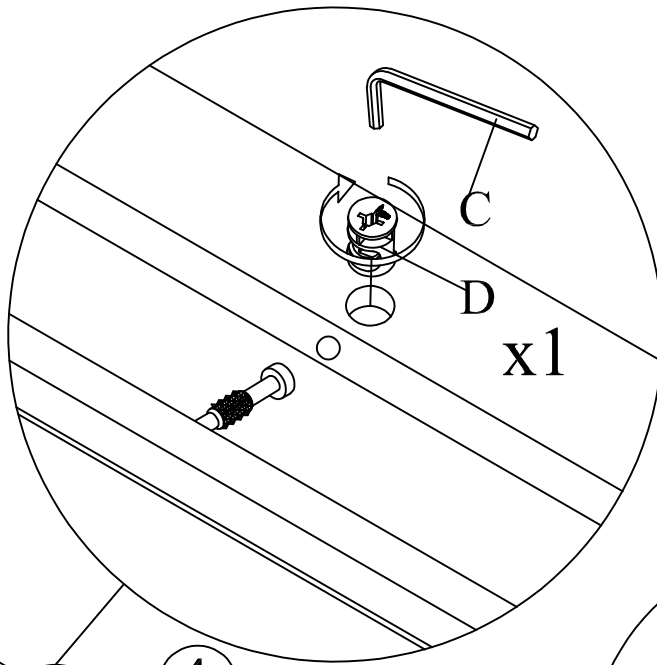

This is how a mini fix works...
 The head of the mini fix housing goes into the open mouth of the mini fix bolt. You then turn the mini fix housing so it tightens over the mini fix bolt.

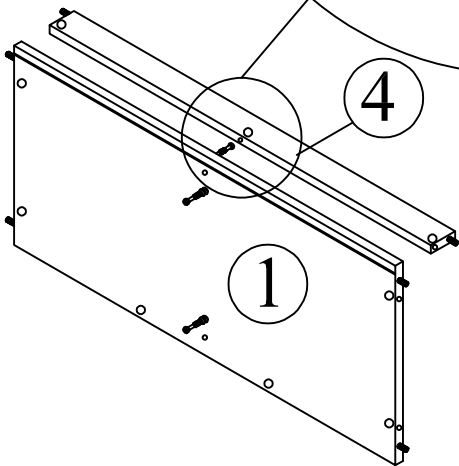
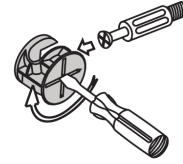

BACK VIEW

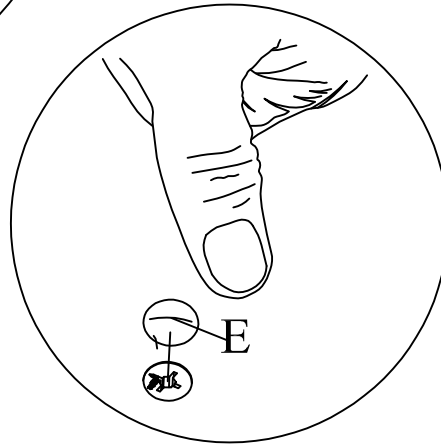

**Attach Minifix Cap as shown.*

Step 4

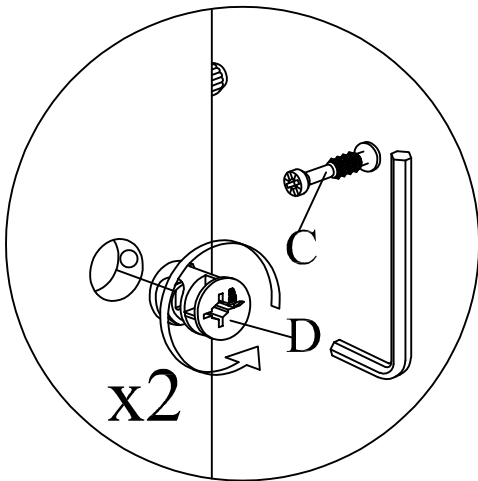

This is how a mini fix works...
 The head of the mini fix housing goes into the open mouth of the mini fix bolt. You then turn the mini fix housing so it tightens over the mini fix bolt.

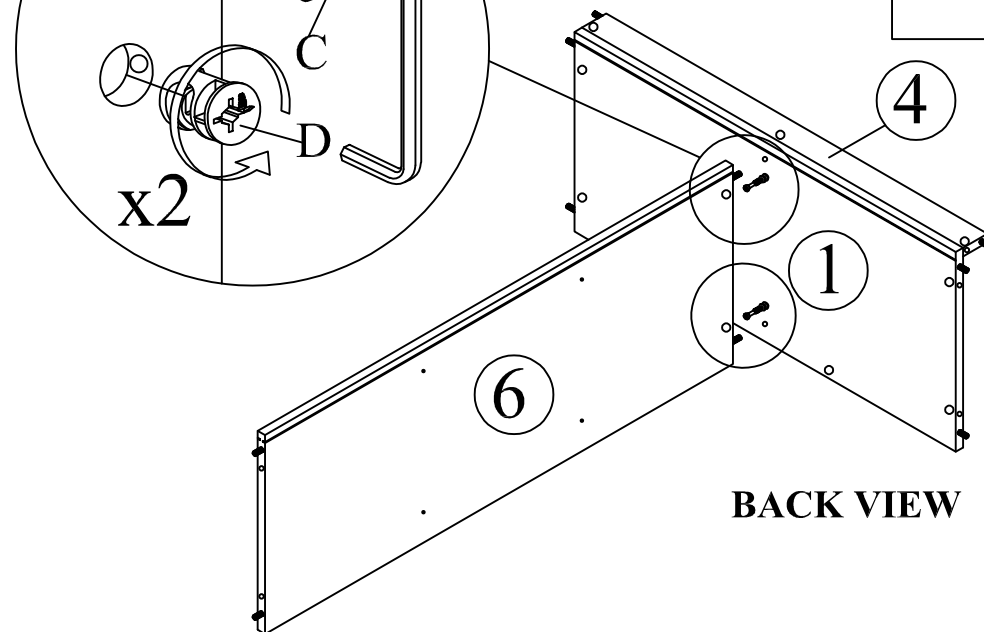
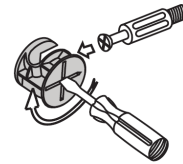

BACK VIEW

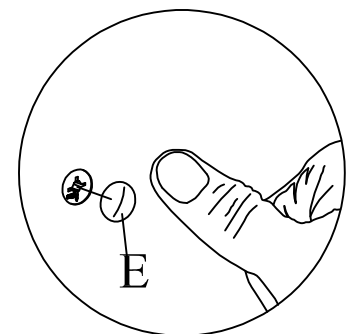

**Attach Minifix Cap as shown.*

Step 5

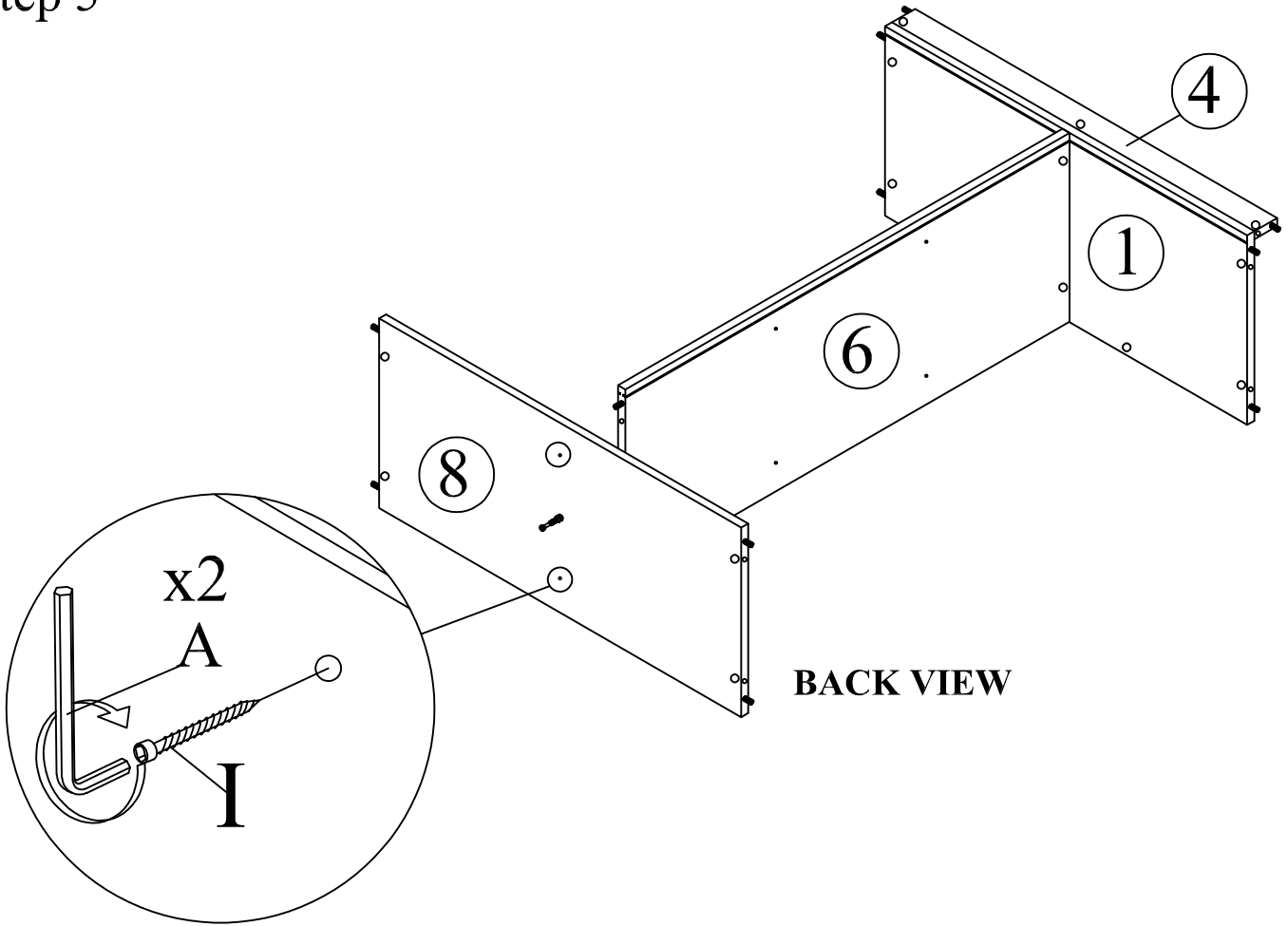

Step 6

This is how a mini fix works...

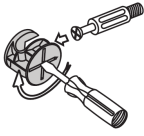

The head of the mini fix housing goes into the open mouth of the mini fix bolt. You then turn the mini fix housing so it tightens over the mini fix bolt.

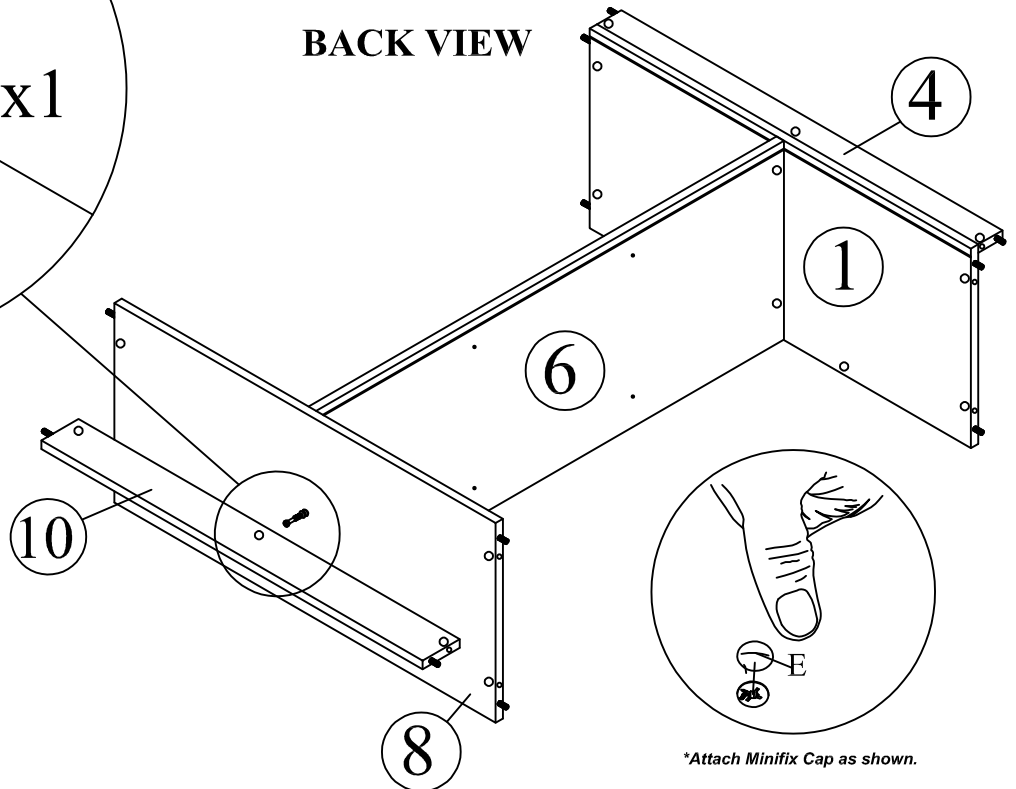
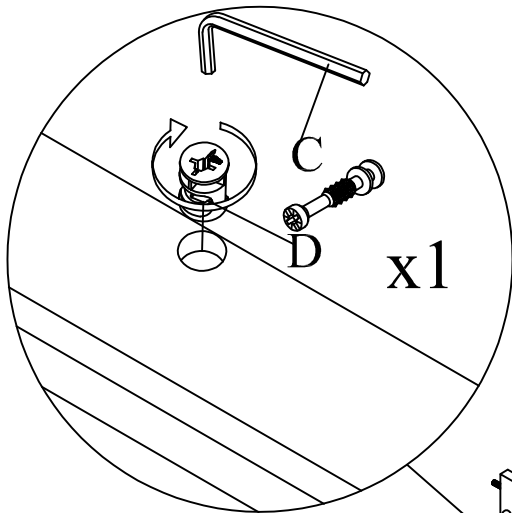

*Attach Minifix Cap as shown.

Step 7

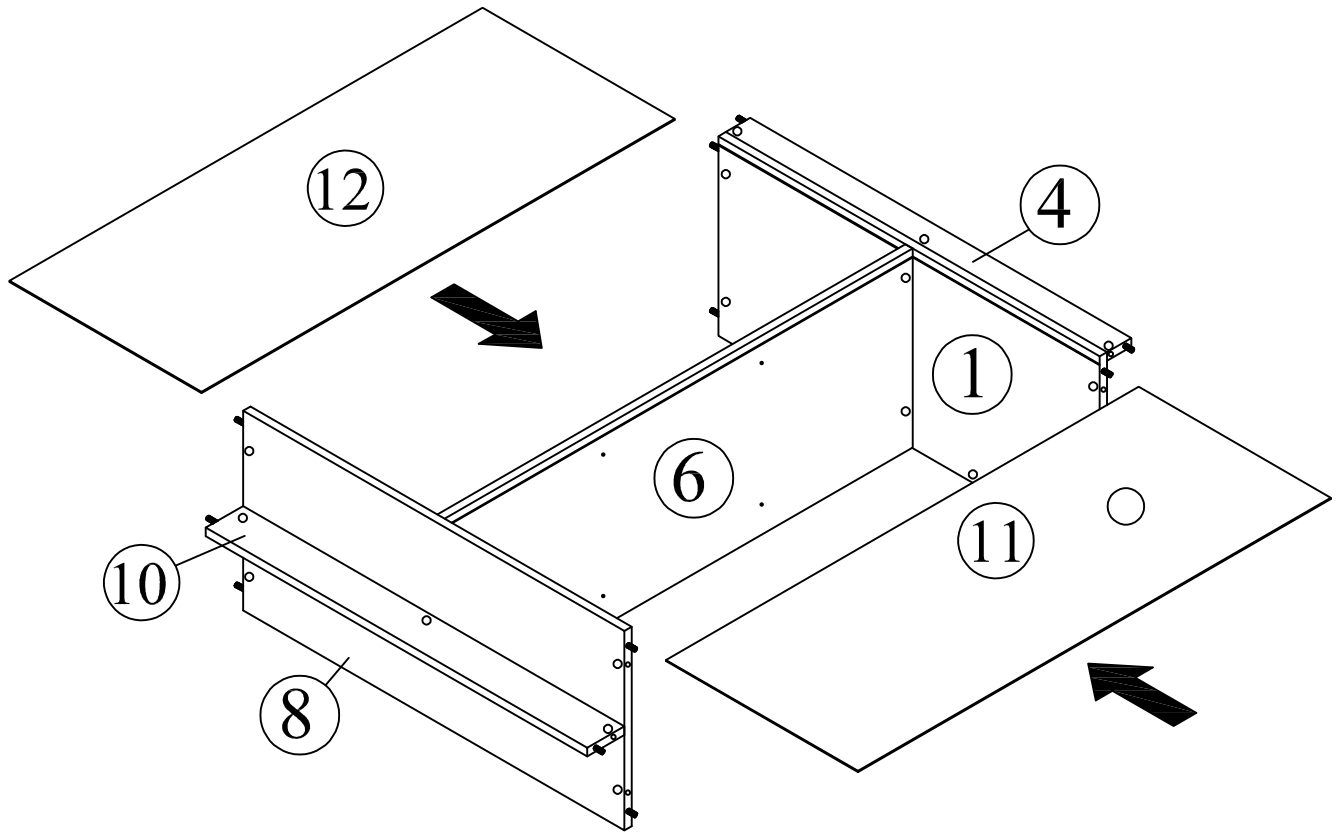

Step 8

This is how a mini fix works...

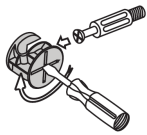

The head of the mini fix housing goes into the open mouth of the mini fix bolt. You then turn the mini fix housing so it tightens over the mini fix bolt.

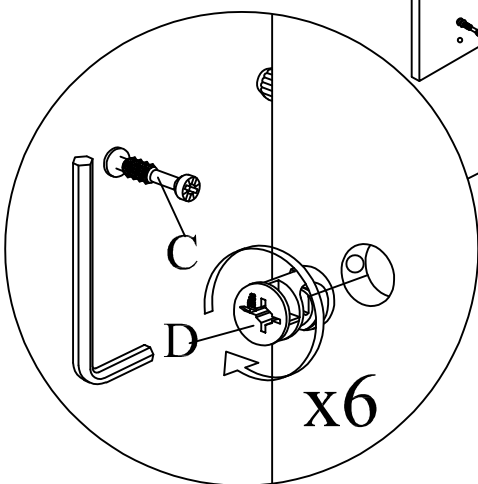
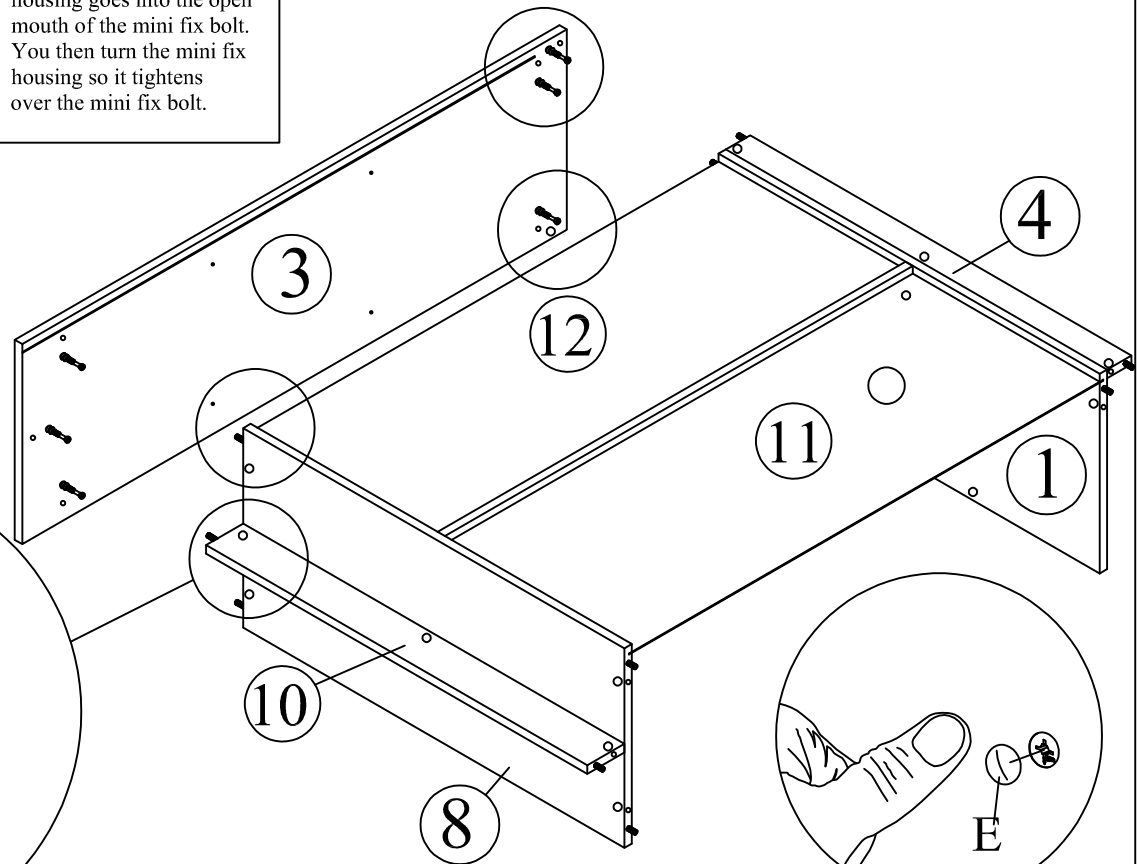

*Attach Minifix Cap as shown.

Step 9

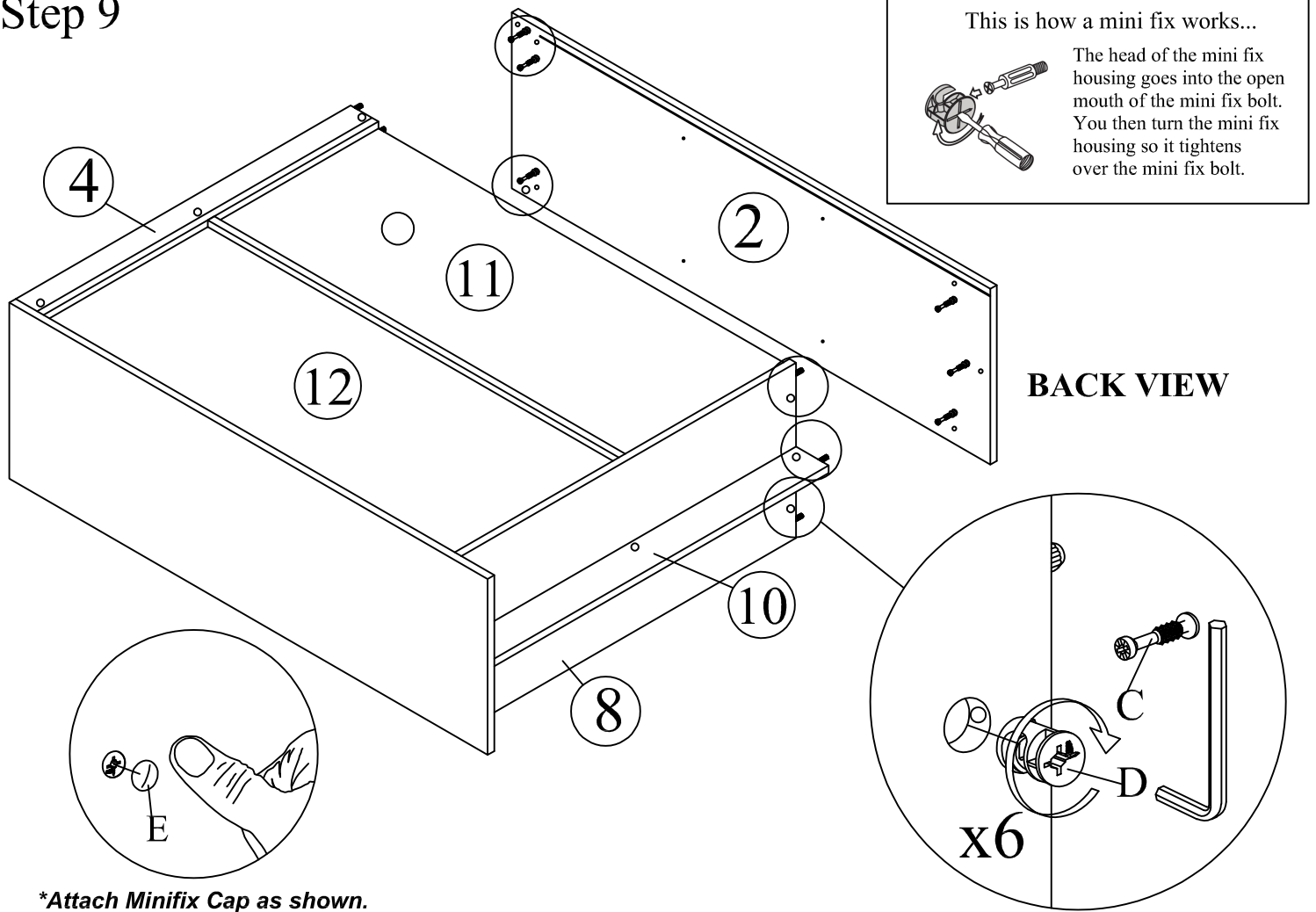

Step 10

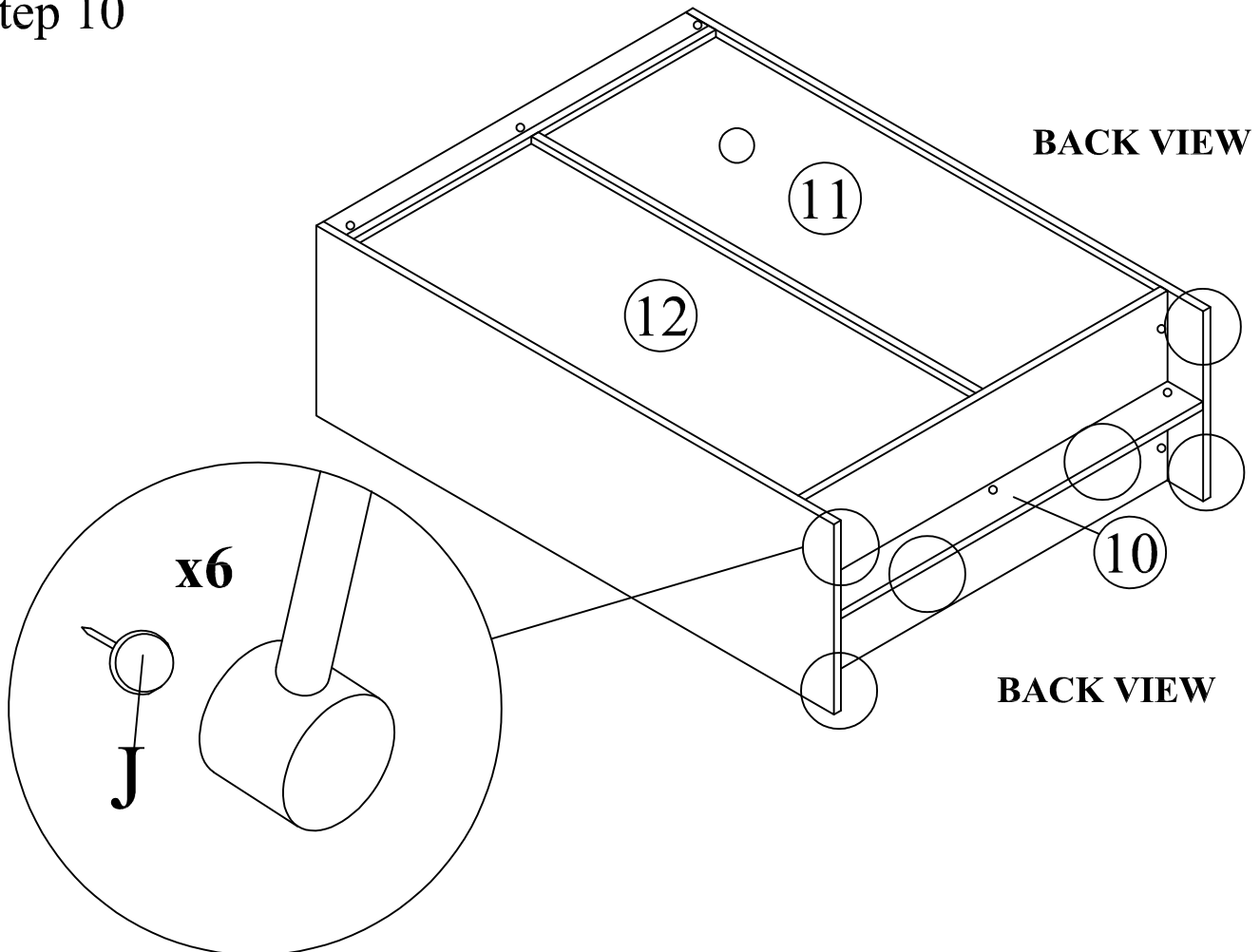

Step 11

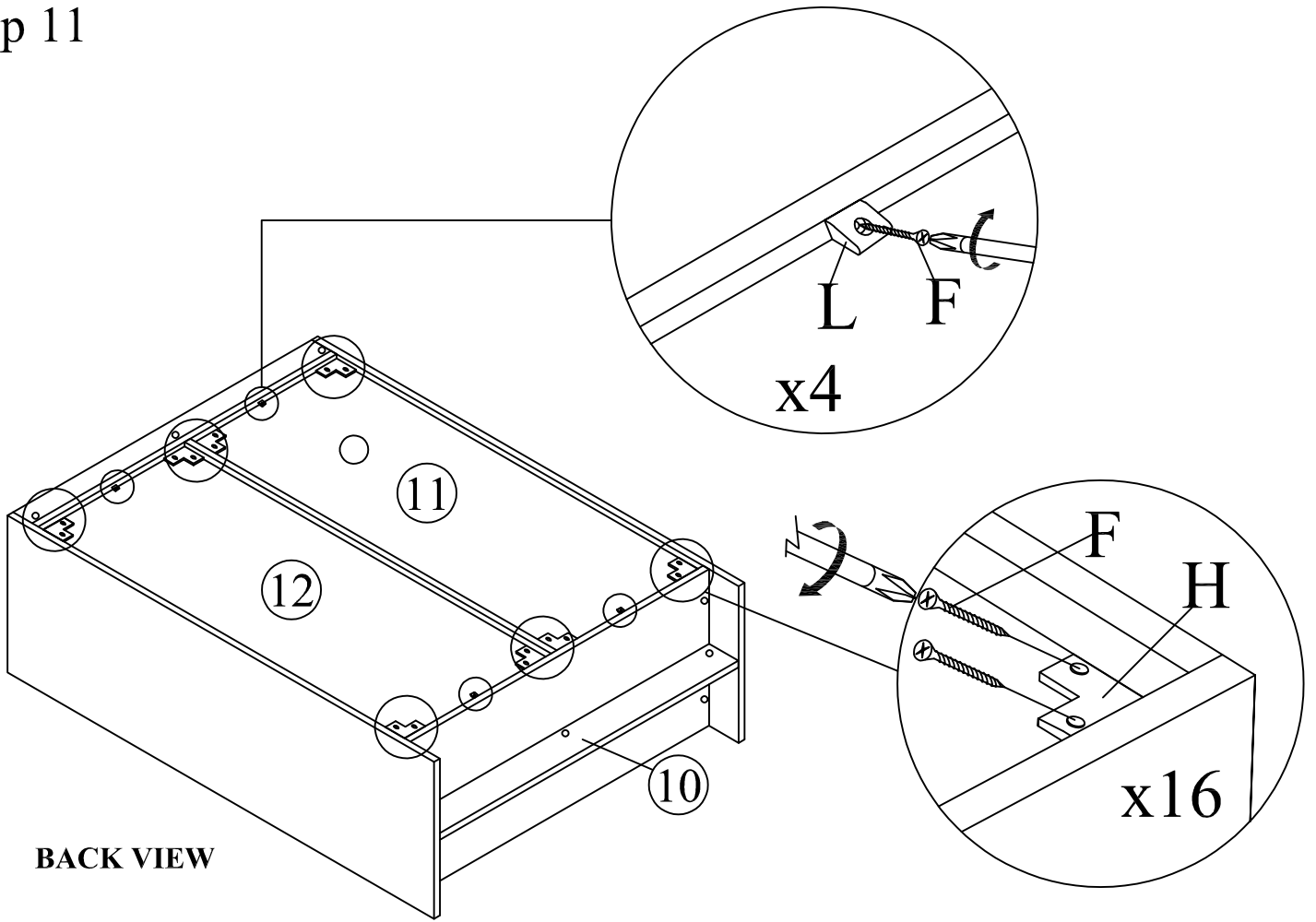

Step 12

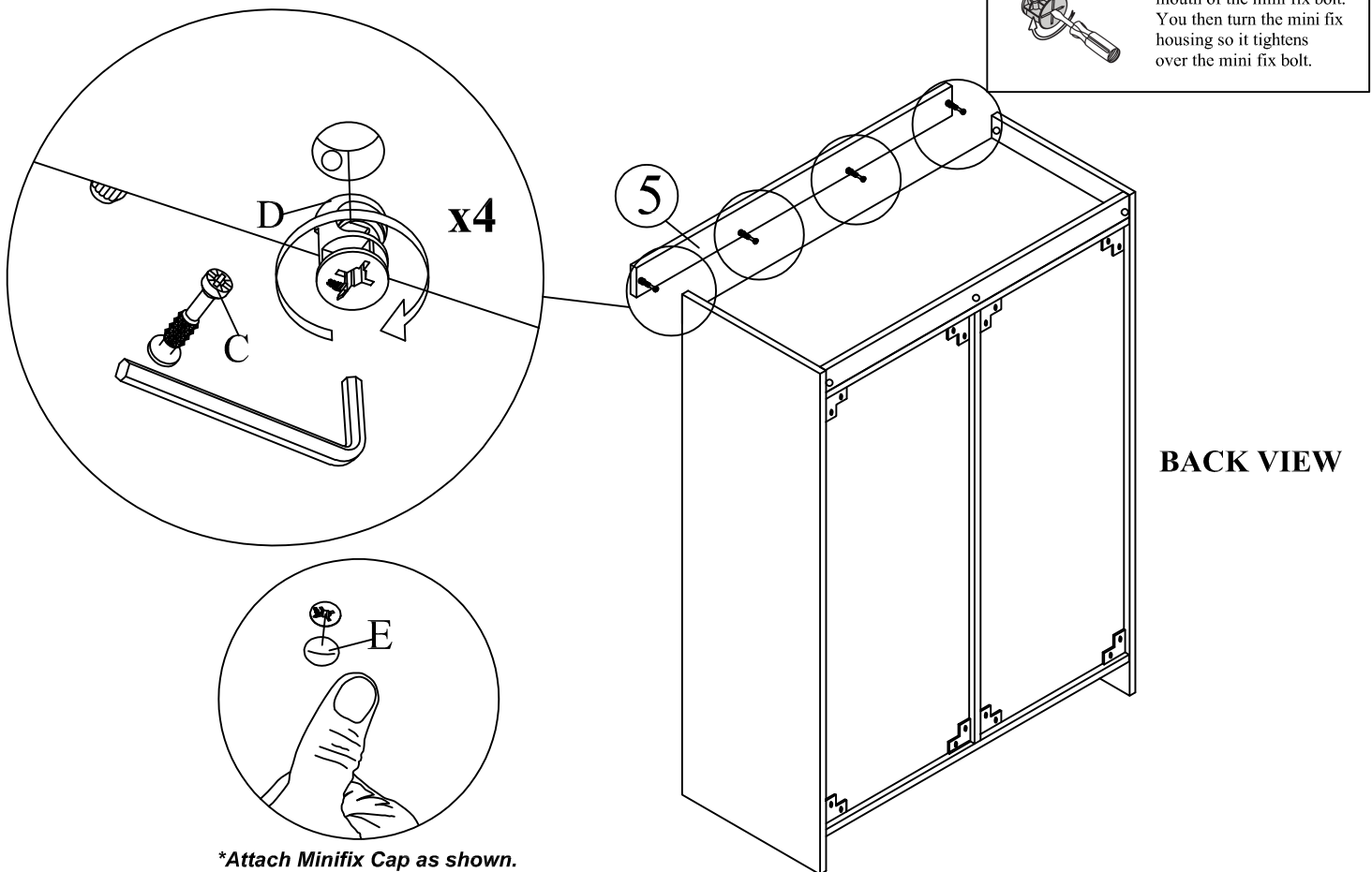

Step 13

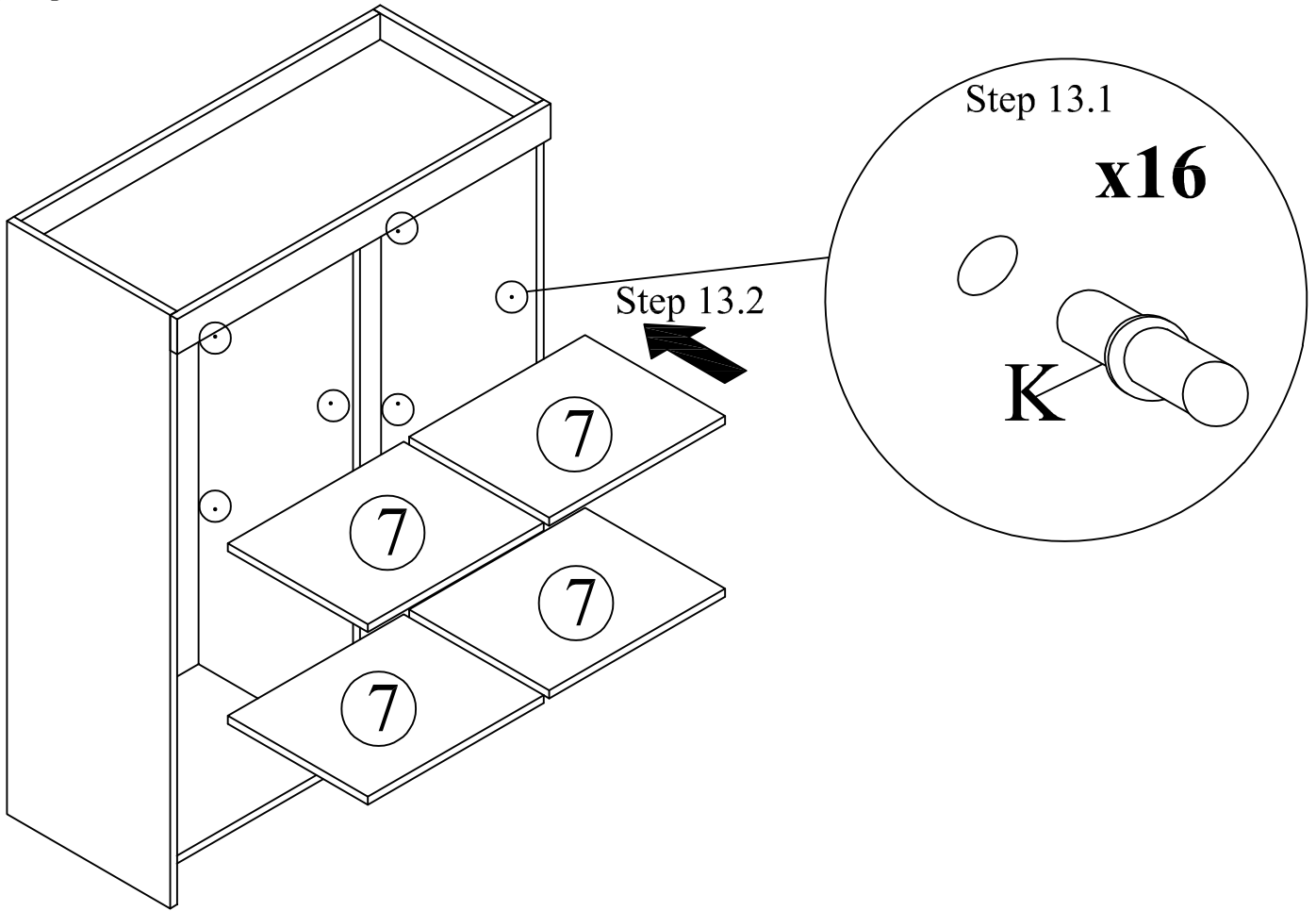

Step 14

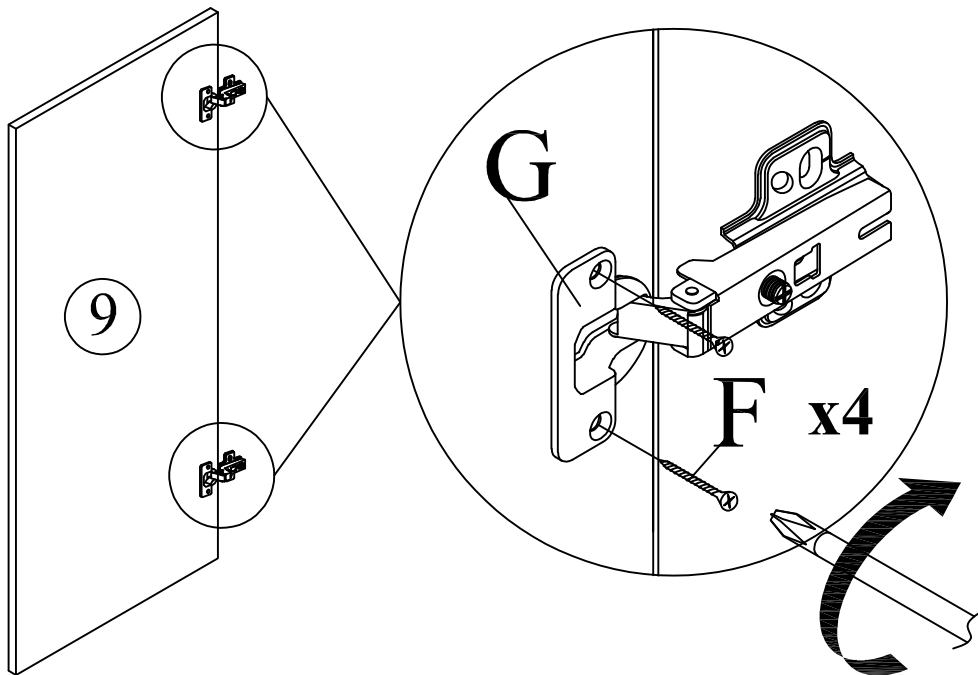

Step 15

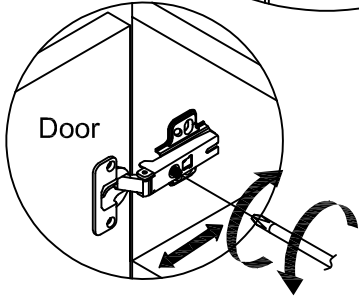
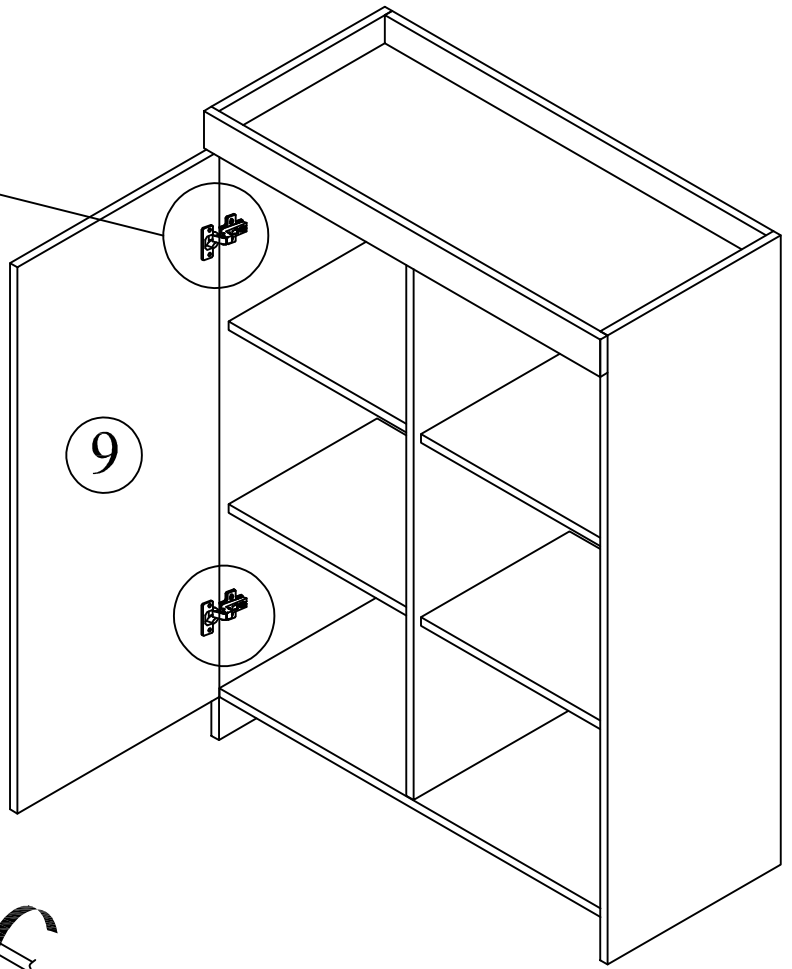
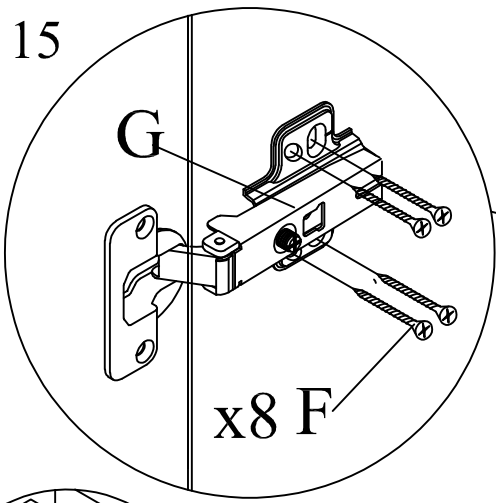

Front to Front Adjustment

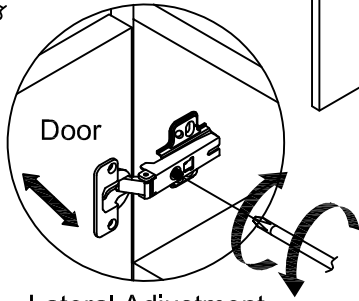

Lateral Adjustment

