

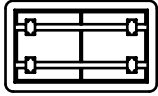

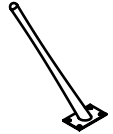

Art.No	WT-1125	
A		1
B		4
T1		16
T2		16
T3		16
T4		16
T5		1





### Step 1

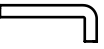
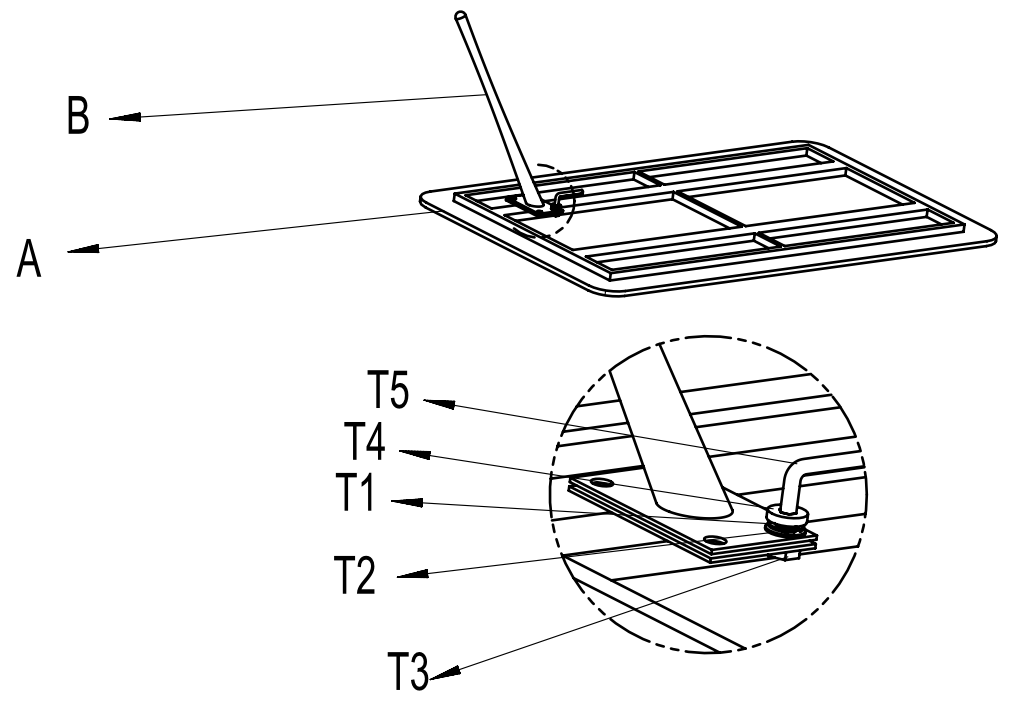

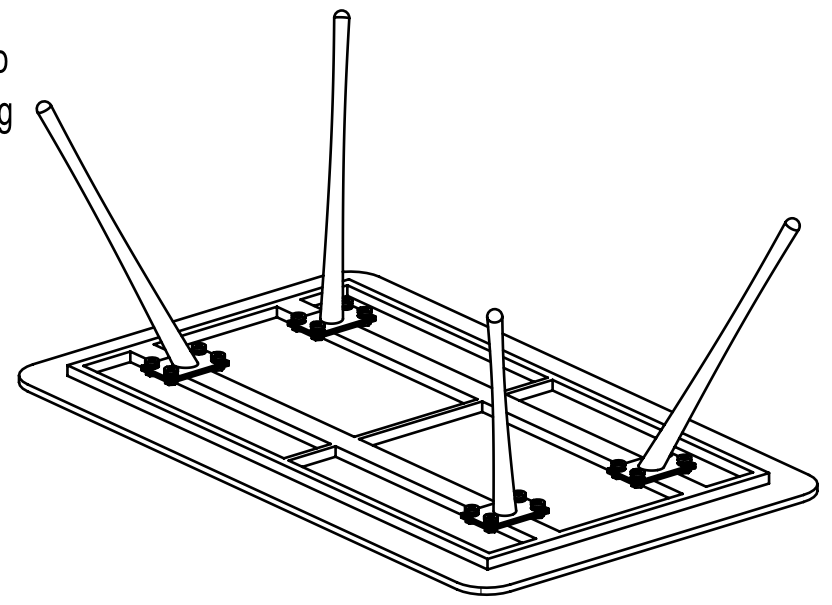
### Step 2

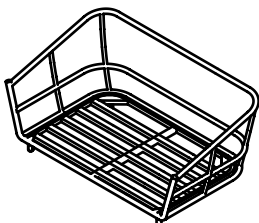
Following the step one method to finish assembling the remaining three legs

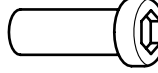
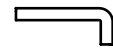

Art.No	WA-6879-2	
A		1
B		4
T1		8
T2		8
T3		8
T4		1

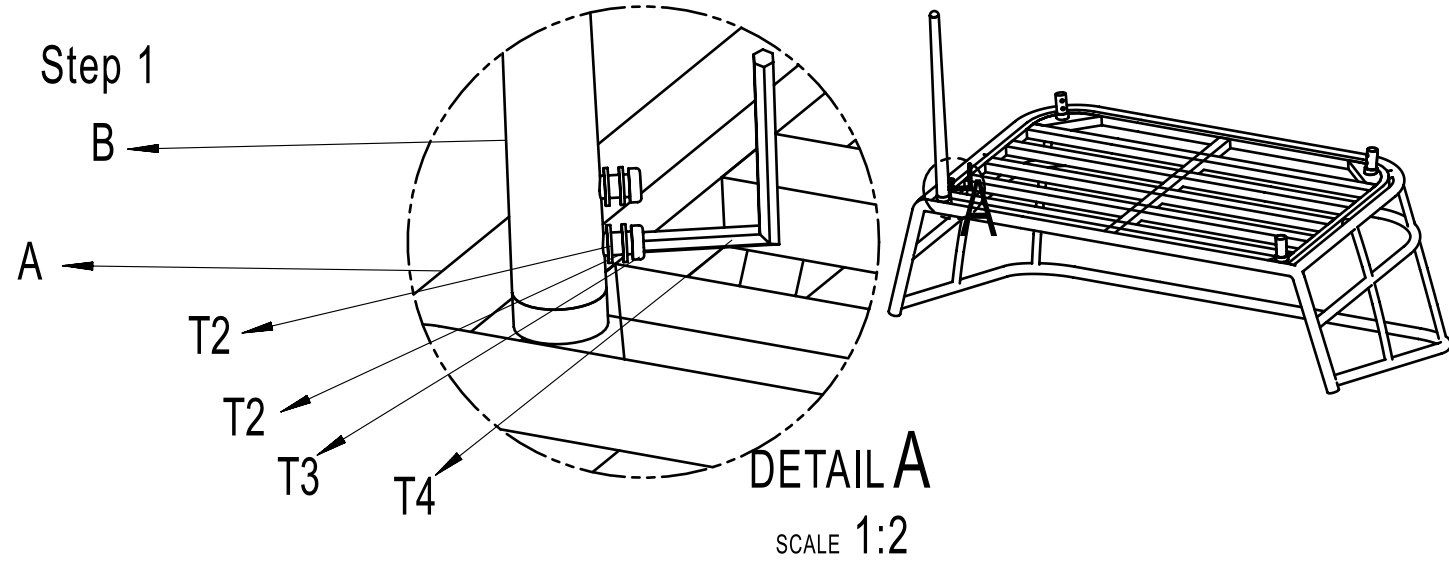



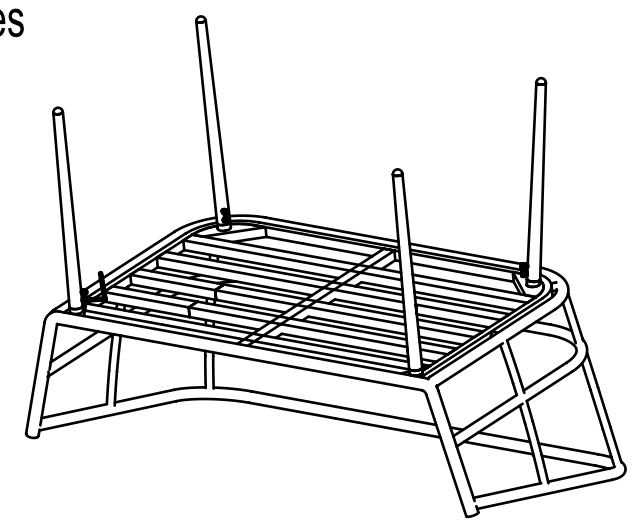

1: Screw up the leg(B) on the seat part(A) by using the tools( T2 T1 T3 T4).  
 Pls mak clearly know the position of T2 and T1.  
 T3 is placed close to the surface of the leg.  
 2: There are two holes on the leg .Screw both holes

Step2

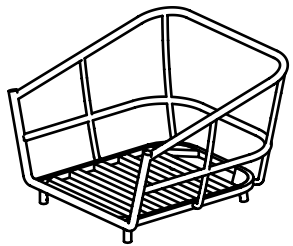
Do the same as step1 to finish assembling the remaining three legs

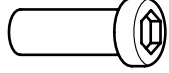
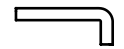

Art.No	WA-6879-1	
A		1
B		4
T1		8
T2		8
T3		8
T4		1

### Step 1

B

T2

T1

T3

A

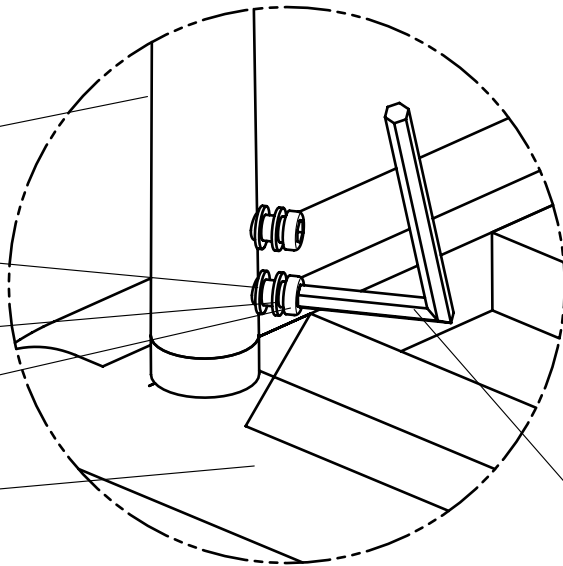

T4

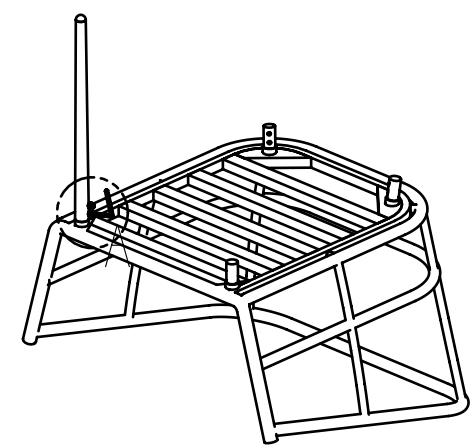

1: Screw up the leg(B) on the seat part(A) by using the tools( T2 T1 T3 T4).

Pls mak clearly know the position of T2 and T1.

T3 is placed close to the surface of the leg.

2: There are two holes on the leg .Screw both holes

### Step2

Do the same as step1 to finish assembling the remaining three legs

