

SW 8180 - F/Q/K

1.

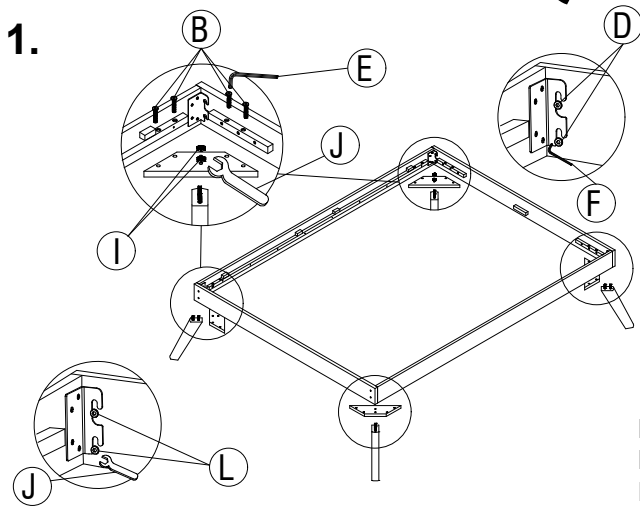

Attach the post (P5) to the corner block (P4). You will need to use hardware:

I = 8pcs J = 1pcs

Attach the side rail (P3) to the headboard panel (P1) and footboard panel (P2). After that, attach the corner block (P4) to the headboard panel (P1), footboard panel (P2) and side rail (P3). You will need to use hardware:

B = 16pcs E = 1pcs
L = 4pcs F = 1pcs
D = 4pcs J = 1pcs

2.

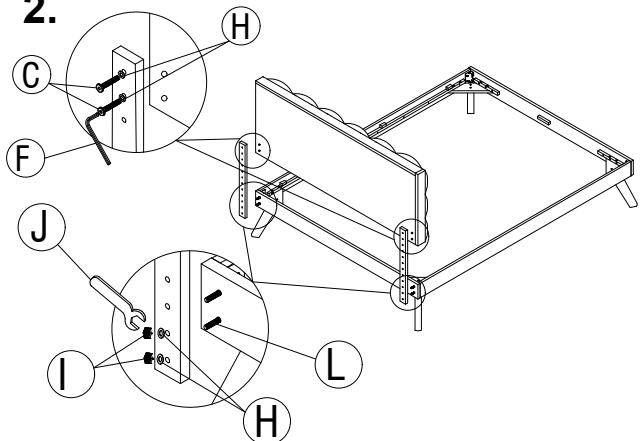

Attach the headboard stand (P7) to the headboard panel (P1) and then attach the headboard (P6) to the headboard stand (P7), according to your desired height. using hardware :

C = 4pcs
F = 1pcs
H = 8pcs
I = 4pcs
J = 1pcs

3.

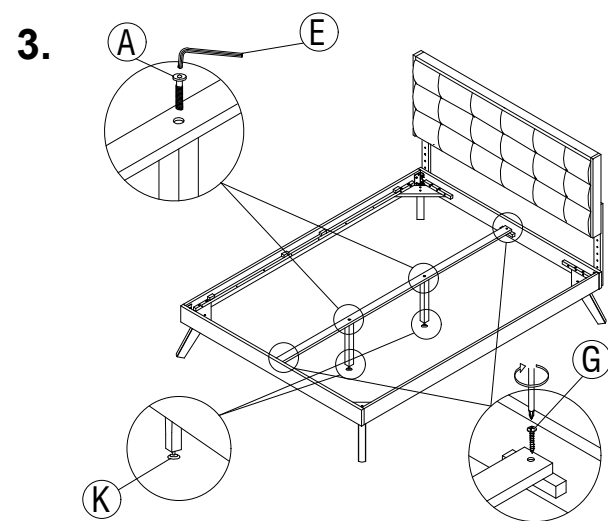

Fix the adjuster (K) to the support leg (P8) using hardware :
K = 2pcs

Attach the support legs (P8) to the center rail (P9) using hardware :
A = 2pcs

Attach the center rail (P9) to the headboard panel (P1) and footboard panel (P2) using hardware :
G = 2pcs

4.

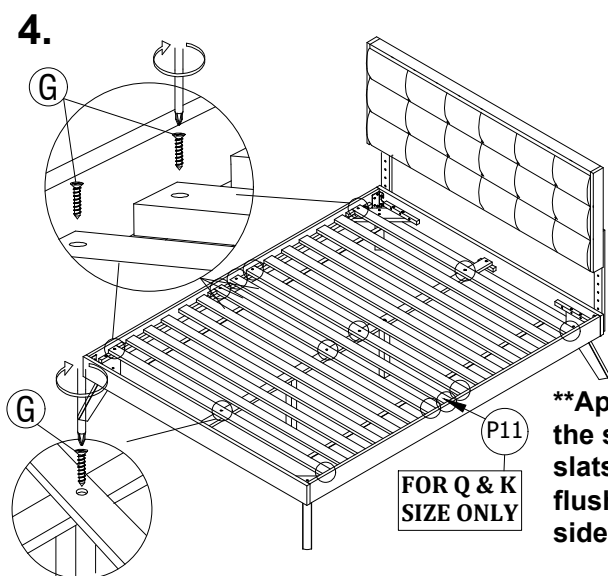

Lay the slats (P10) between the side rail (P3) using hardware :
G = 8pcs

For Q & K size bed :Lay the middle slats (P11) between the bed slats (P10) using hardware :
G = 2pcs

Attach the slats (P10) to the center rail (P9) using hardware :
G = 4pcs

****Apply pressure with your knee to the side rails whilst attaching the slats to ensure that the slats are flush against the inside of side rails.****

FOR Q & K SIZE ONLY

WARNING!!

- Remove hardware from box and sort by size.
- Please check to see that hardware and parts are present prior start of assembly.
- Please follow attached instruction in the same sequence numbered to ensure fast and easy assembly.
- Do not use this bed if any part is broken, torn or missing.
- The assembly of this product requires two people.
- Do not use any power tools as this may damage the frame and will invalidate any claim.

PART LIST

P1		Headboard Panel	=	1pcs
P2		Footboard Panel	=	1pcs
P3		Side Rail	=	2pcs
P4		Corner Block	=	4pcs
P5		Post	=	4pcs
P6		Headboard	=	1pcs
P7		Headboard Stand	=	2pcs
P8		Support Leg	=	2pcs
P9		Center Rail	=	1pcs
P10		Slat (F/Q/K)	=	2sets
P11		Middle Slat (Q/K)	=	1pcs

HARDWARE LIST

A		M6 X 50MM JCBC	=	2pcs
B		M6 X 30MM JCBC	=	16pcs
C		M8 X 50MM JCBB	=	4pcs
D		M8 X 16MM JCBB	=	4pcs
E		ALLEN KEY M4	=	1pcs
F		ALLEN KEY M5	=	1pcs
G		M4 X 25MM SCREW(Q/K) M4 X 25MM SCREW(F)	=	16pcs 14pcs
H		FLAT WASHER	=	8pcs
I		HEX NUT 5 / 16	=	12pcs
J		WRENCH	=	1pcs
K		ADJUSTER	=	2pcs
L		HEX COM 5 / 16 X 50MM	=	4pcs

