











# W110297

6x25mm  ax2	6x10mm  gx6
 bx1	 hx8
6x45mm  cx16	4x12mm  ix2
5x45mm  dx8	 jx2
 ex8	 kx2
 fx10	

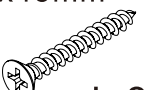

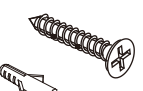
1

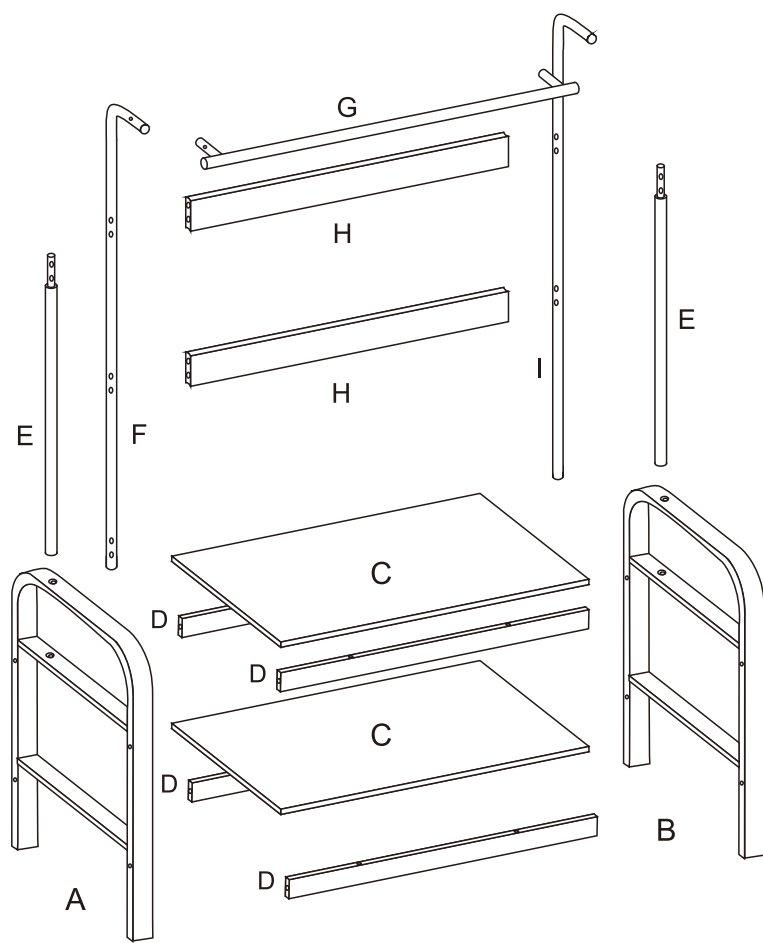
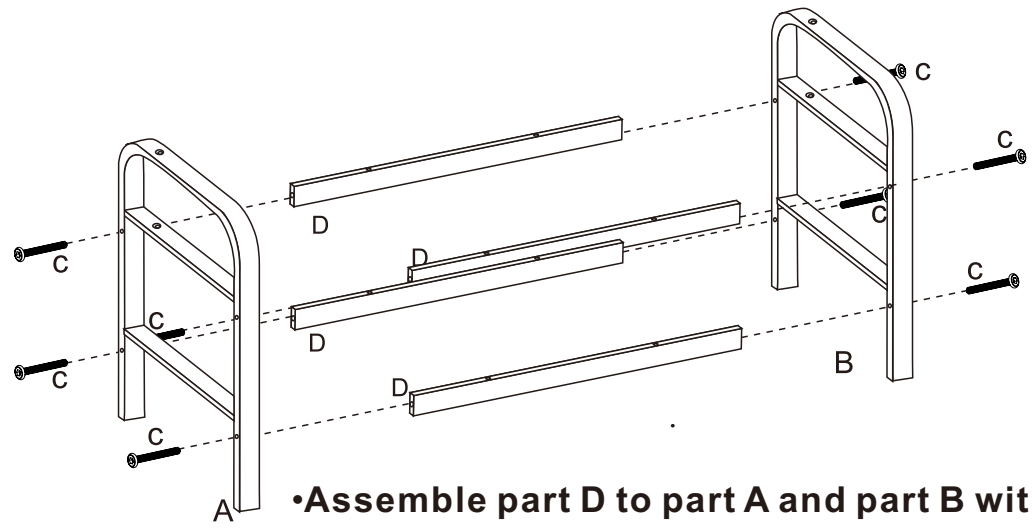

2

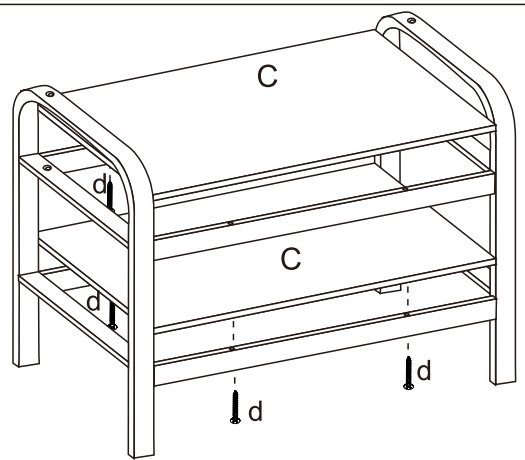

•Insert part C to assembled unit with screw d as shown

3

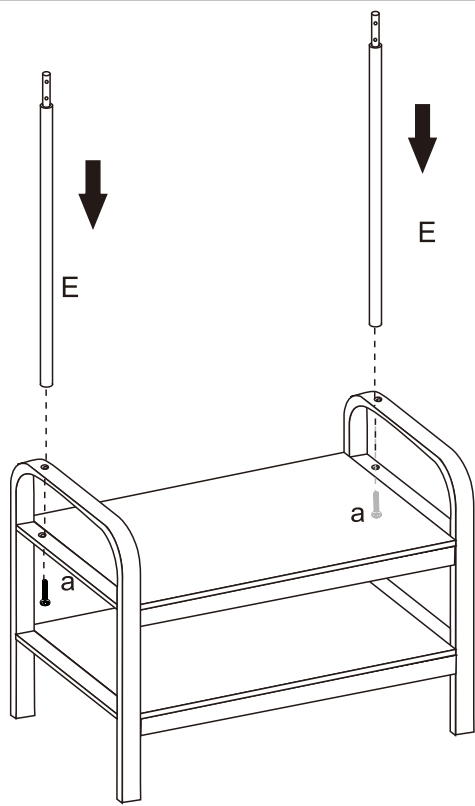

•Insert part E to assembled unit with screw a .

4

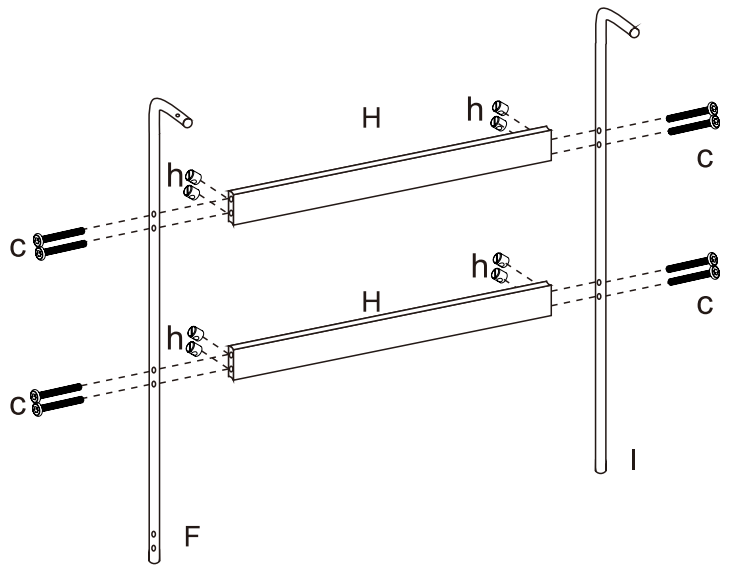

•Fix part H to part F/I with screw c.

5

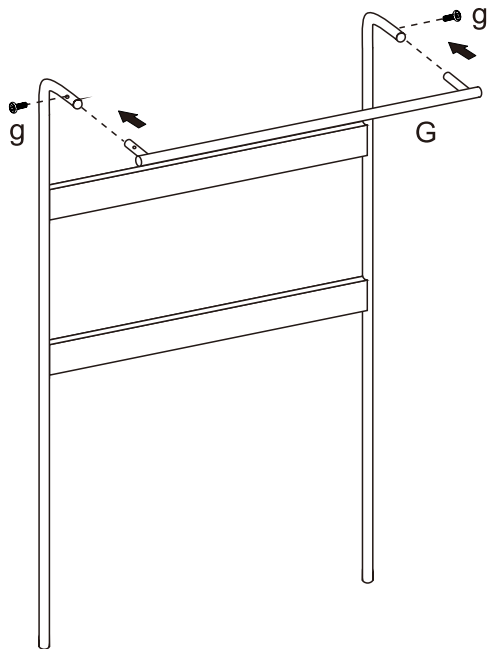

•Insert G part to the assembled unit with screw g.

6

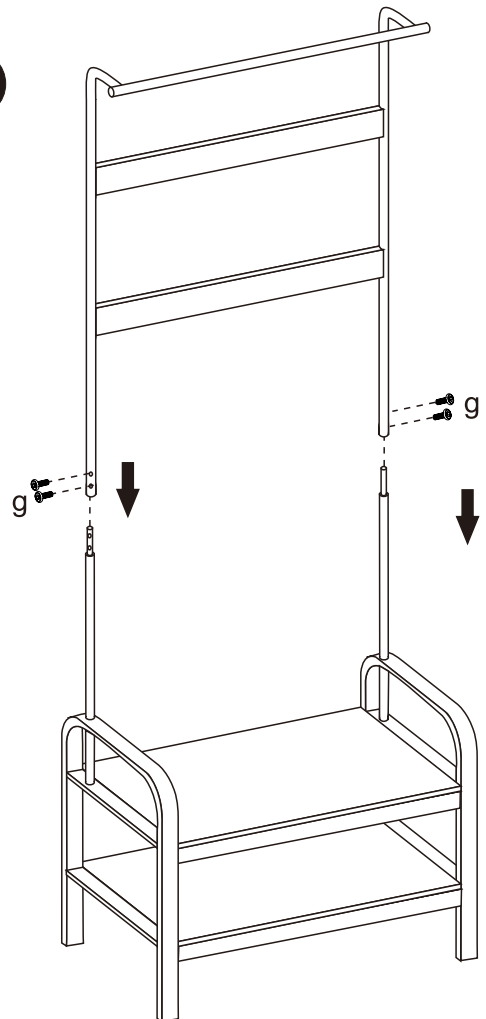

•Attach the assembled unit to part E with screw g.

7

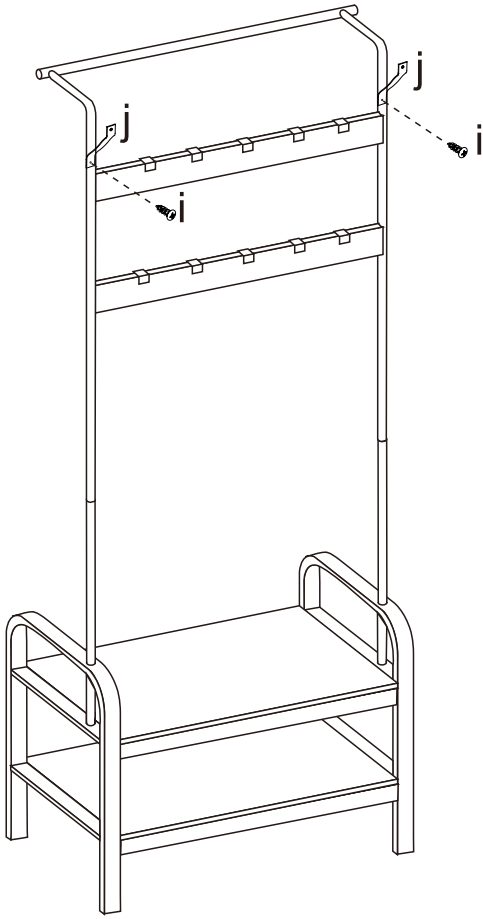

•Connect Part J to the assembled unit with screws i.

8

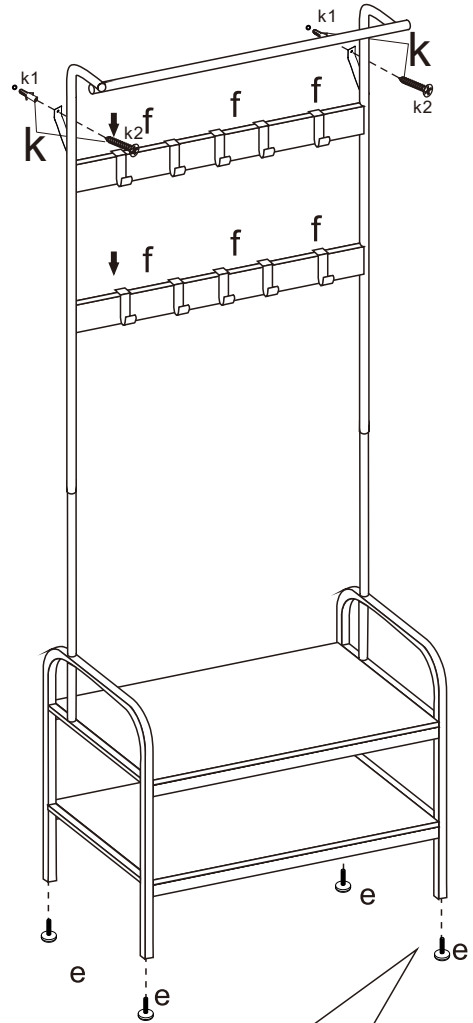

- Insert the K1 with hammer to the wall.
- Fix the product to the wall with screw K2.
- Insert hardware e to assembled unit as picture.
- Hang hardware f to assembled unit as picture.