

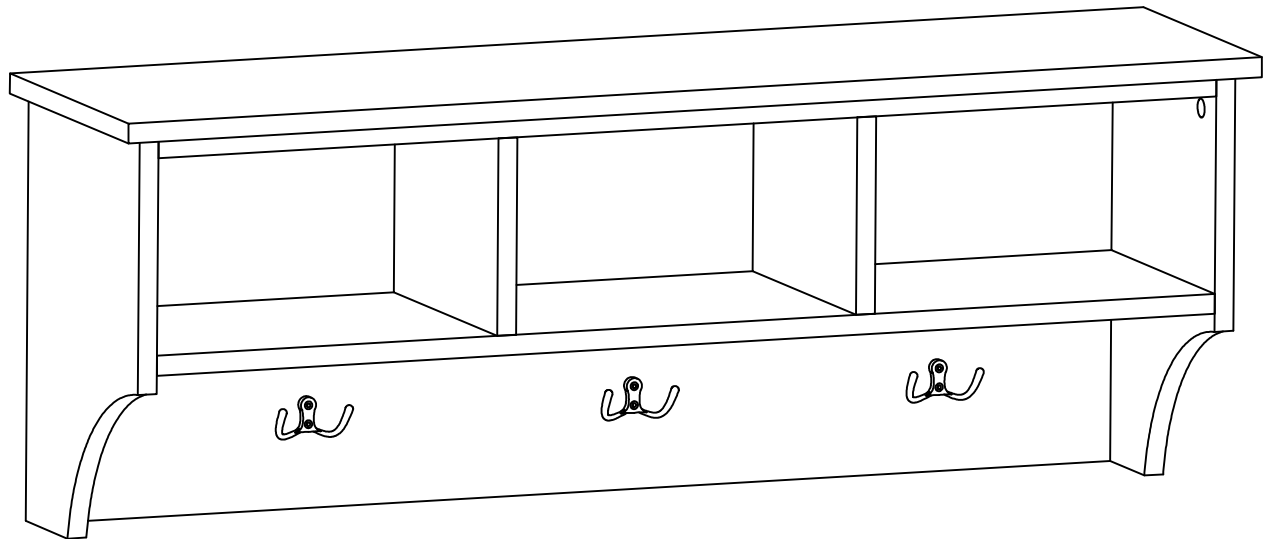









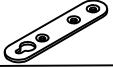

WI9020/WI9021/WI9022

Assembly Instructions



Hardware List

ITEM	PART	QTY	ITEM	PART	QTY
A		18pcs	G	 Ø4x30mm	4pcs
B		18pcs	H		2pcs
C		18pcs	I		2pcs
D	 Ø4x25mm	4pcs	J	 Ø4x35mm	2pcs
E		3pcs	K	 Ø3x16mm	6pcs
F	 Ø3x14mm	6pcs			

Part List

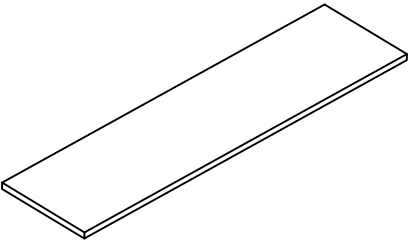
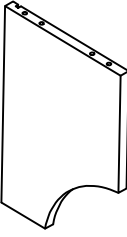
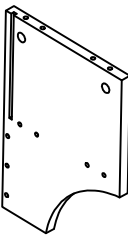
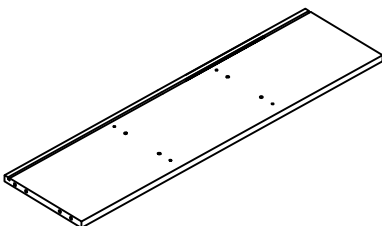
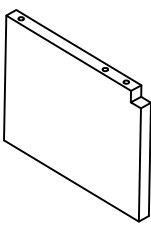
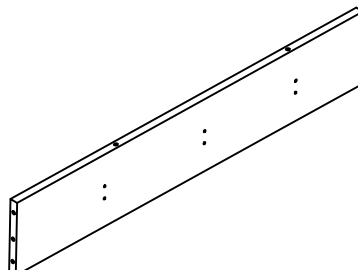
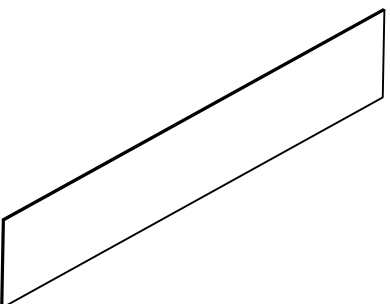
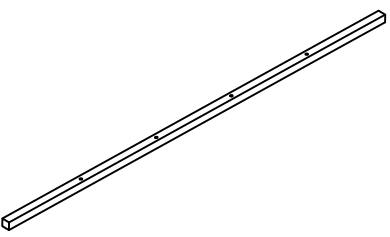
ITEM	PART	QTY	ITEM	PART	QTY
1		1pc	2		1pc
3		1pc	4		1pc
5		2pcs	6		1pc
7		1pc	8		1pc

STEP 1

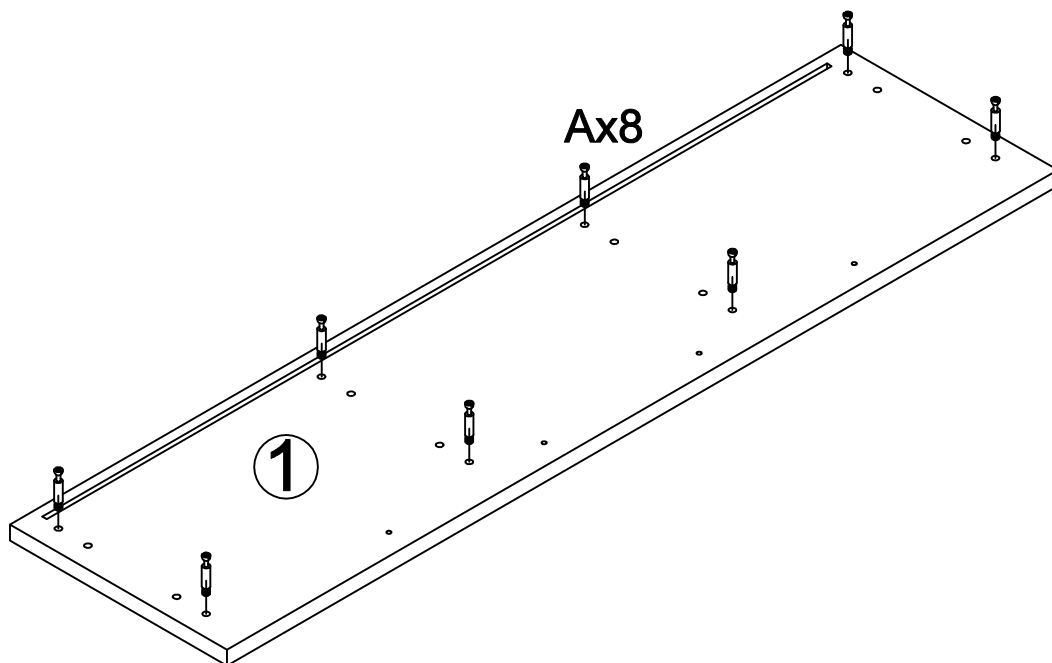

•Screw part A and part ① together.

STEP 2

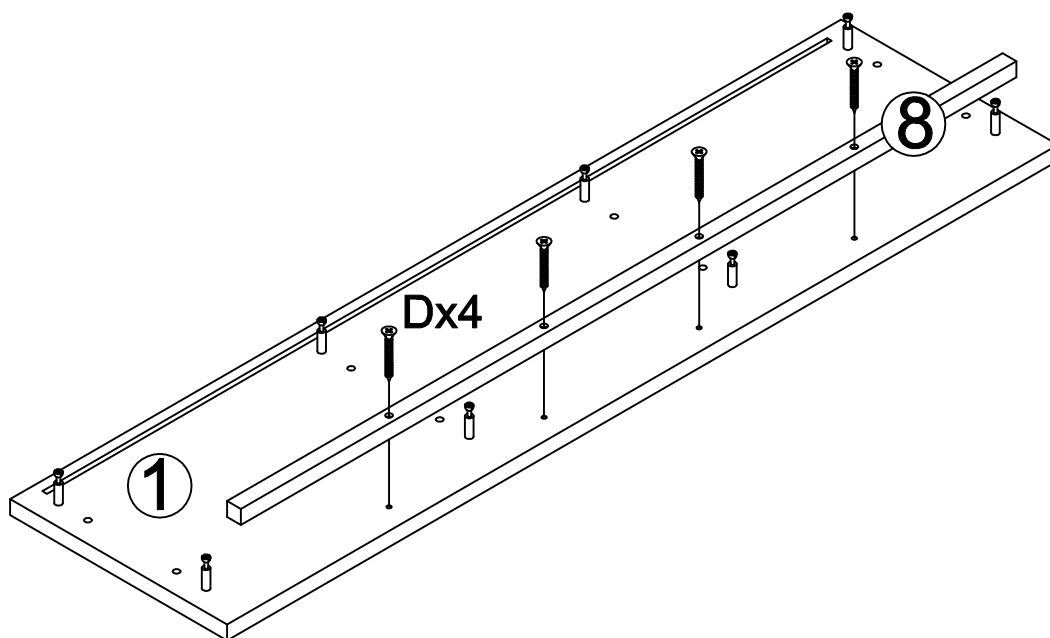

•Fix the ⑧ part to the ① part with the hardware D.

STEP 3

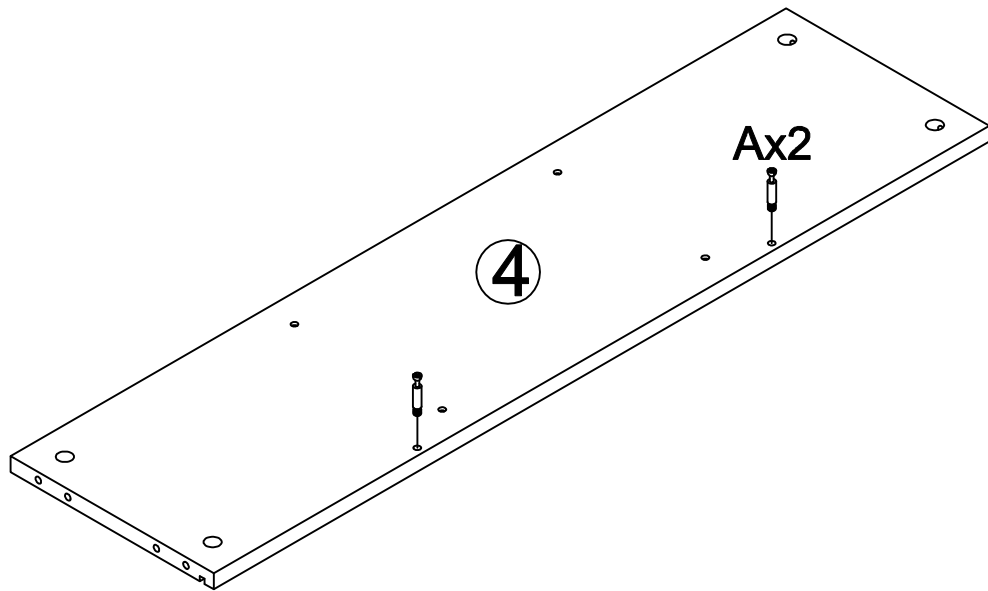

•Screw part A and part ④ together.

STEP 4

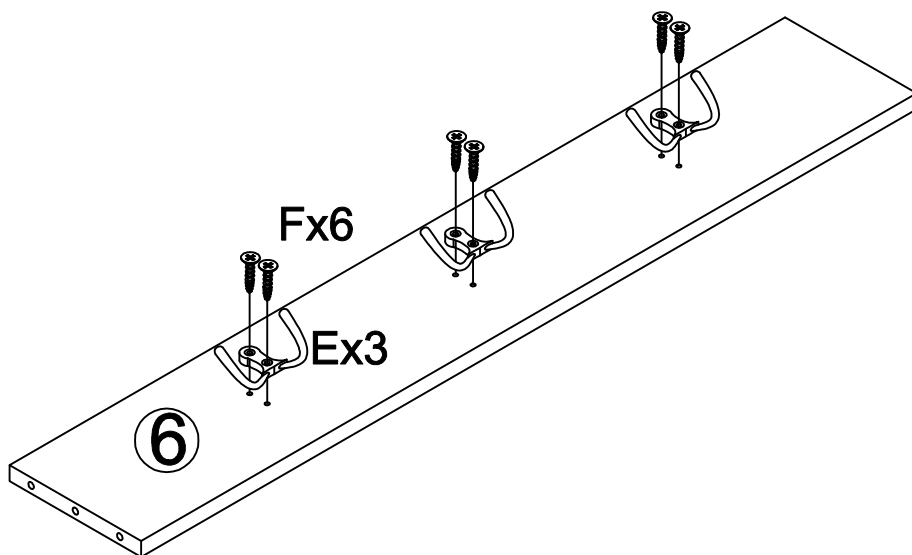

•Fix the E part to the ⑥ part with the hardware F.

STEP 5

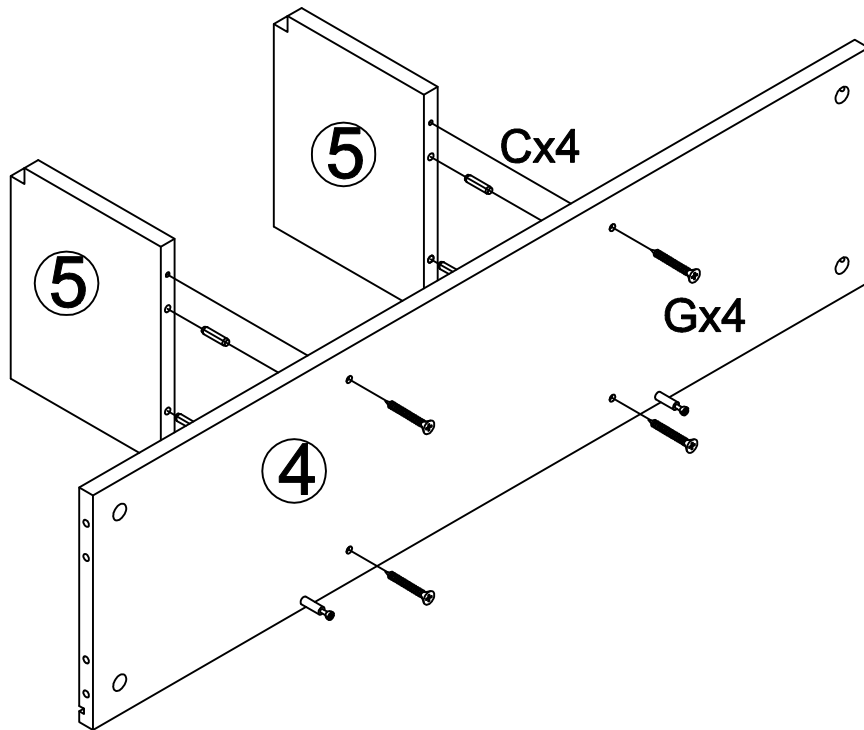

·Fix the ⑤ part to the ④ part with the hardware G/C.

STEP 6

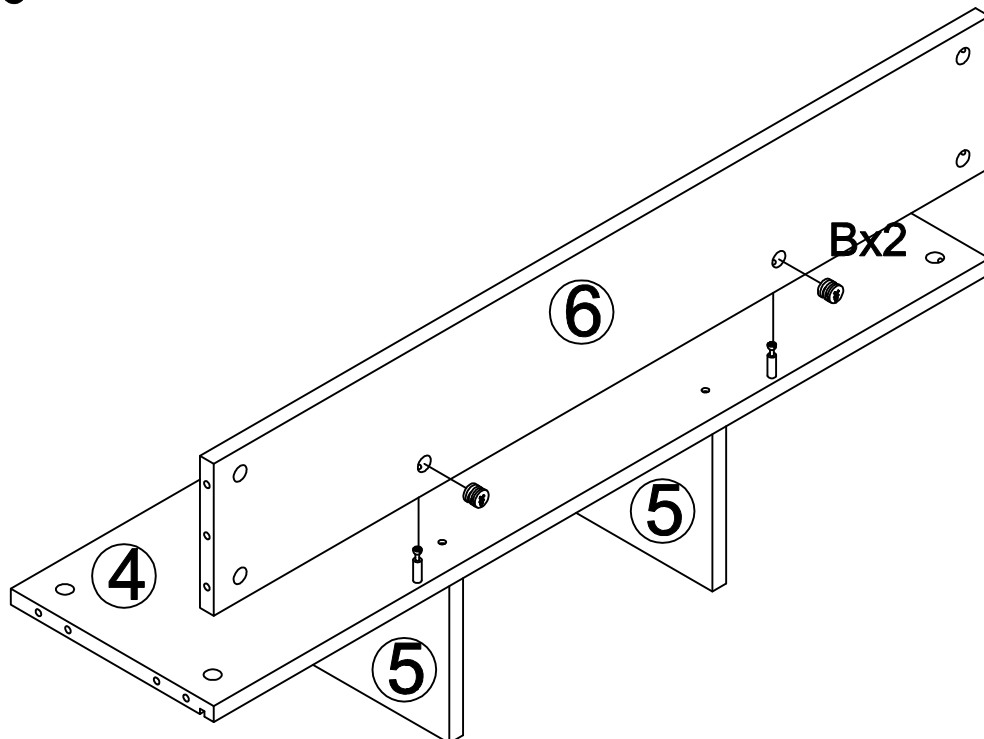

·Fix the ⑥ part to the ④ part with the hardware B.

STEP 7

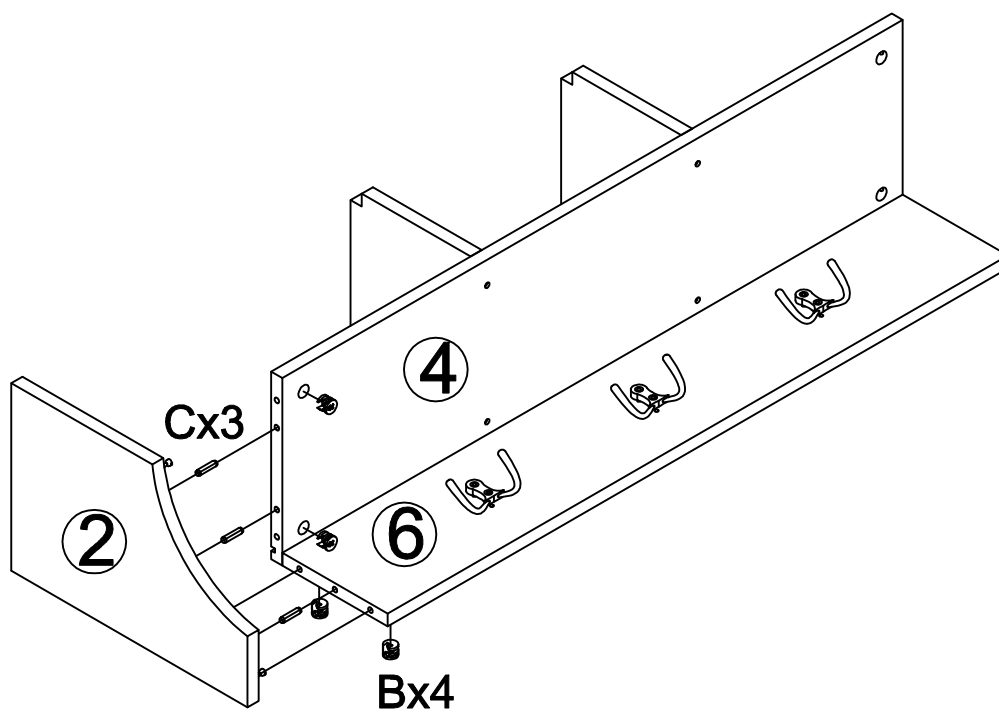

·Fix the ② part to the ④/⑥ part with the hardware C/B.

STEP 8

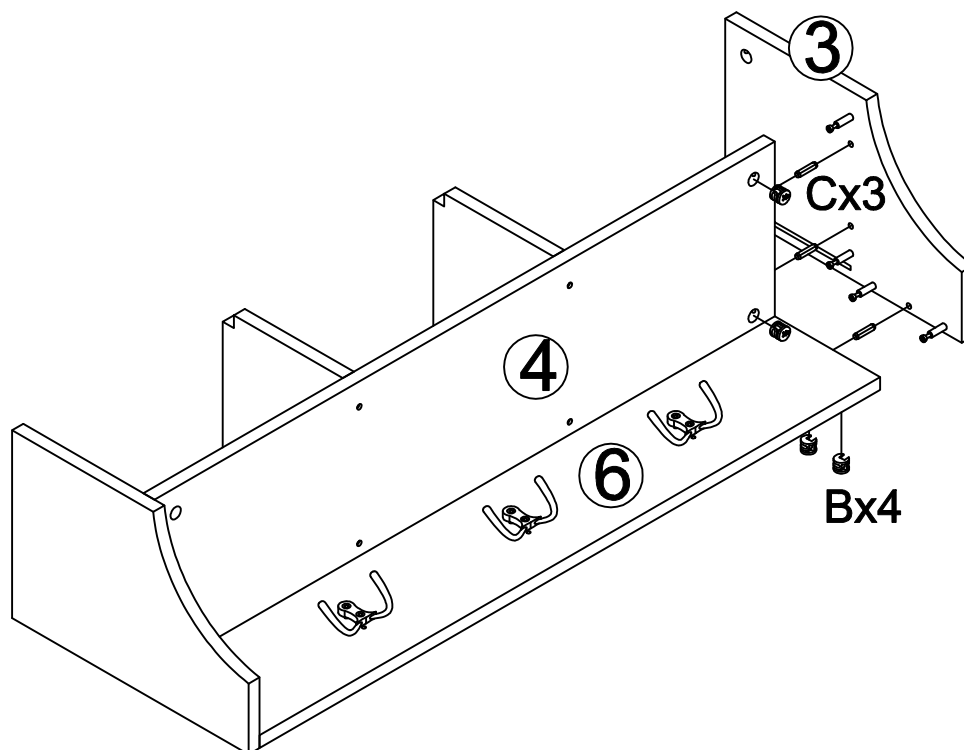

·Fix the ③ part to the ④/⑥ part with the hardware C/B.

STEP 9

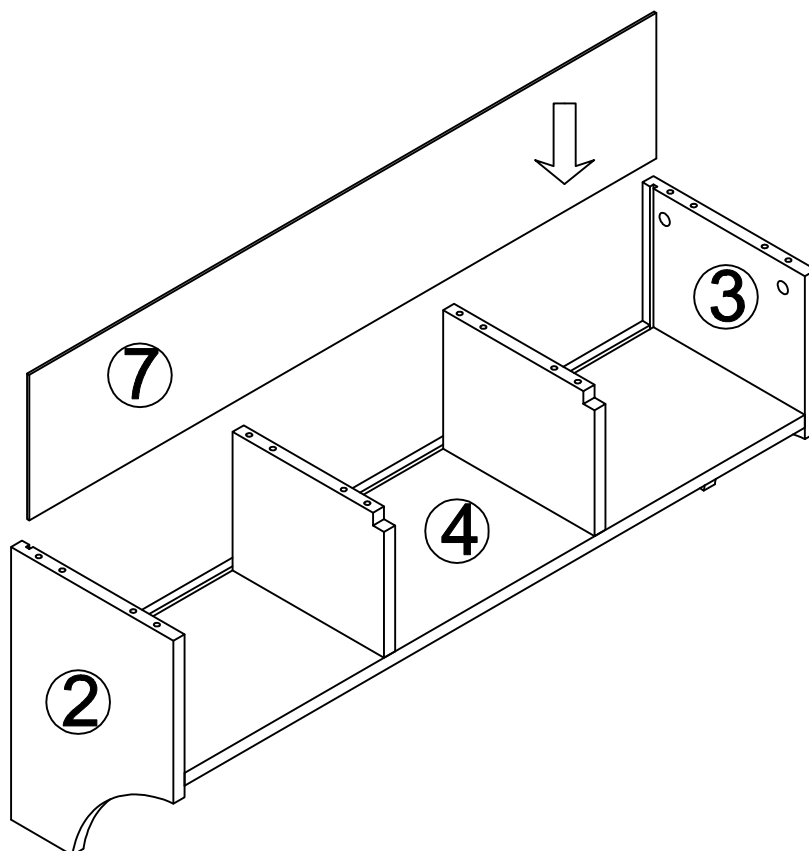

STEP 10

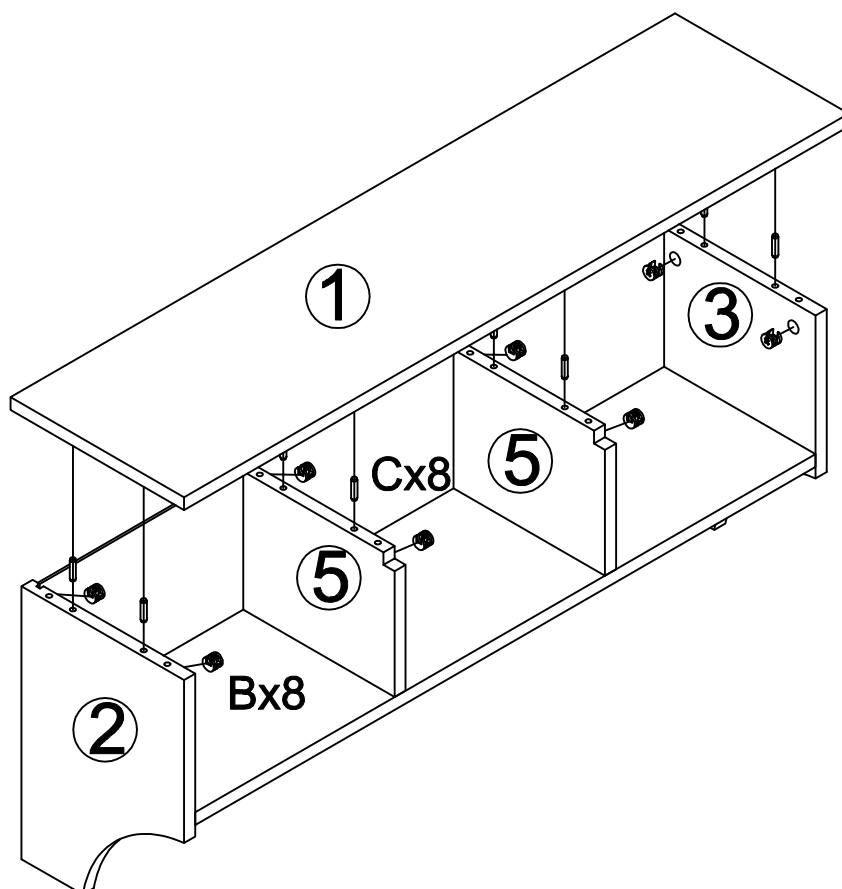

·Fix the ① part to the ②/③/④/⑤ part with the hardware C/B.

STEP 11

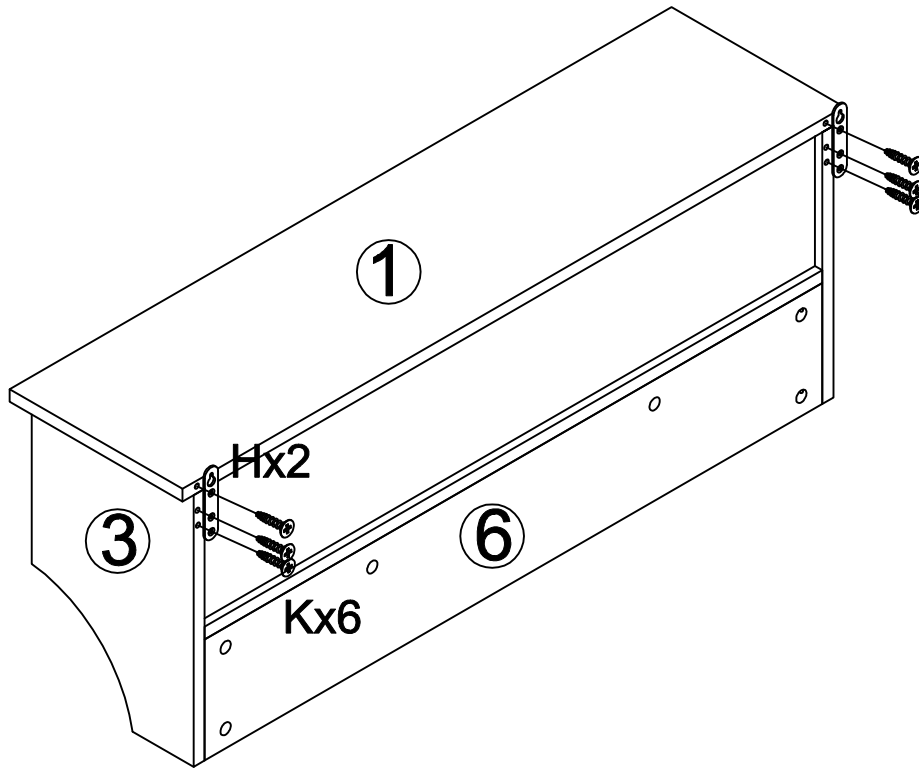

•Fix the H2 part to the ① part with the hardware K.

STEP 12

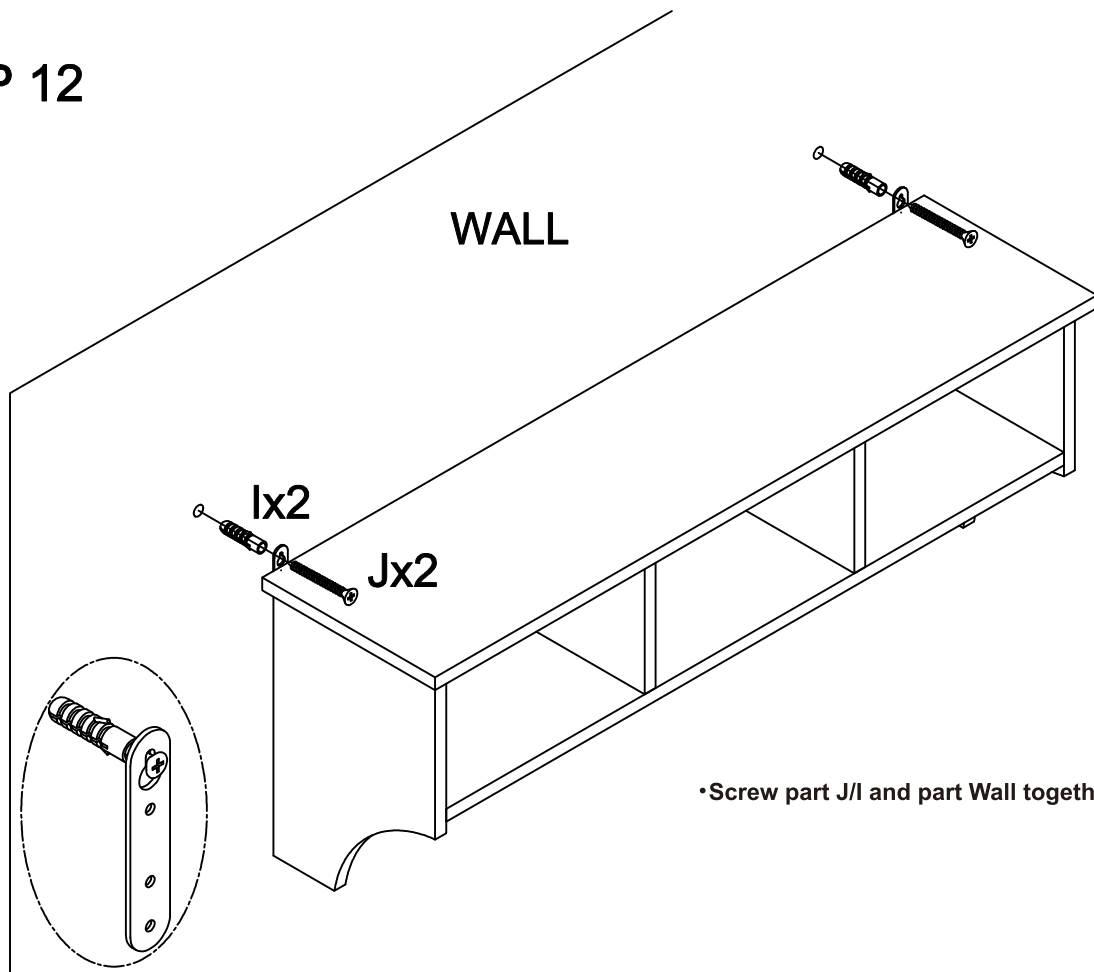

•Screw part J/I and part Wall together.