

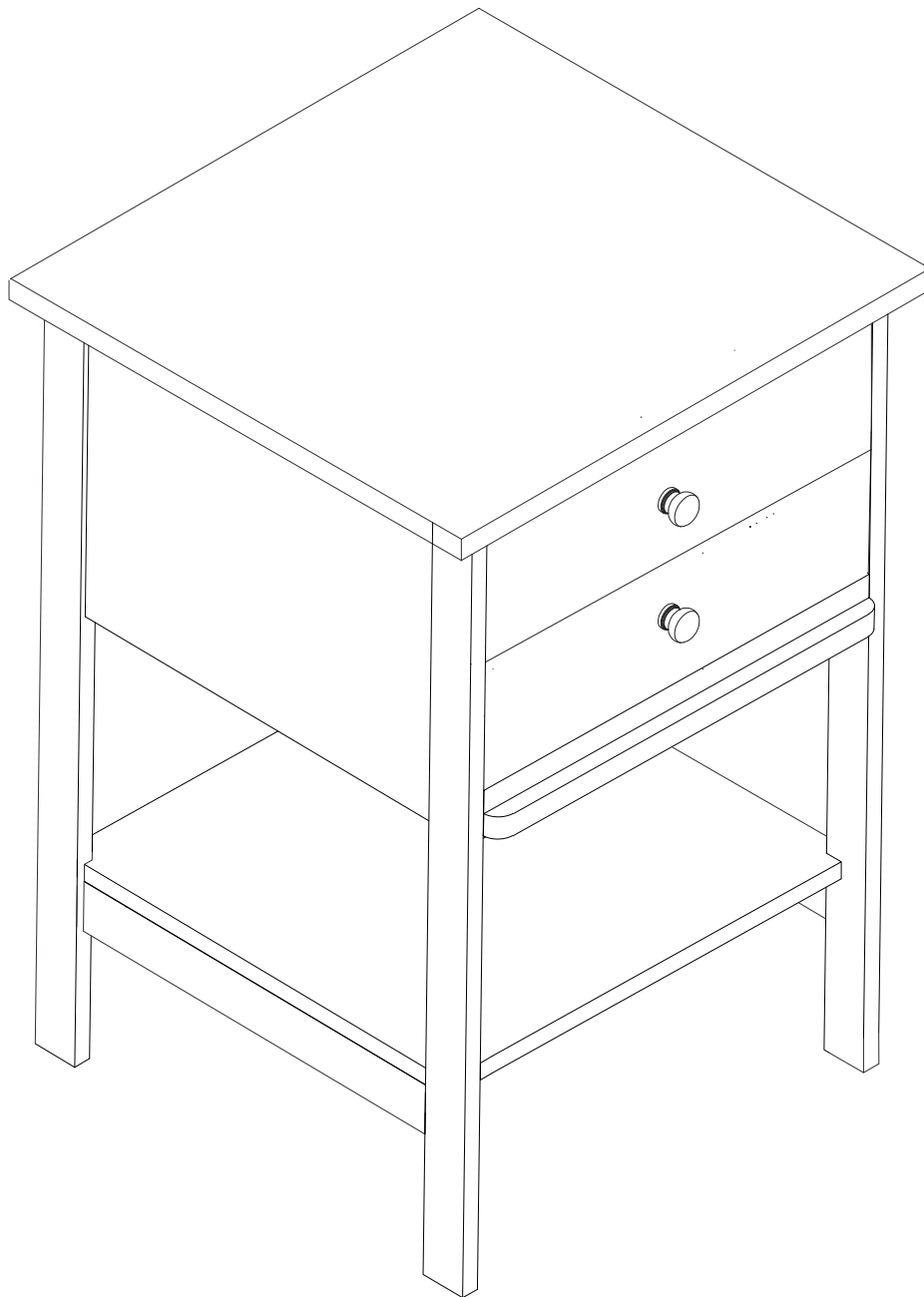

WI9032 WI9033 WI9034

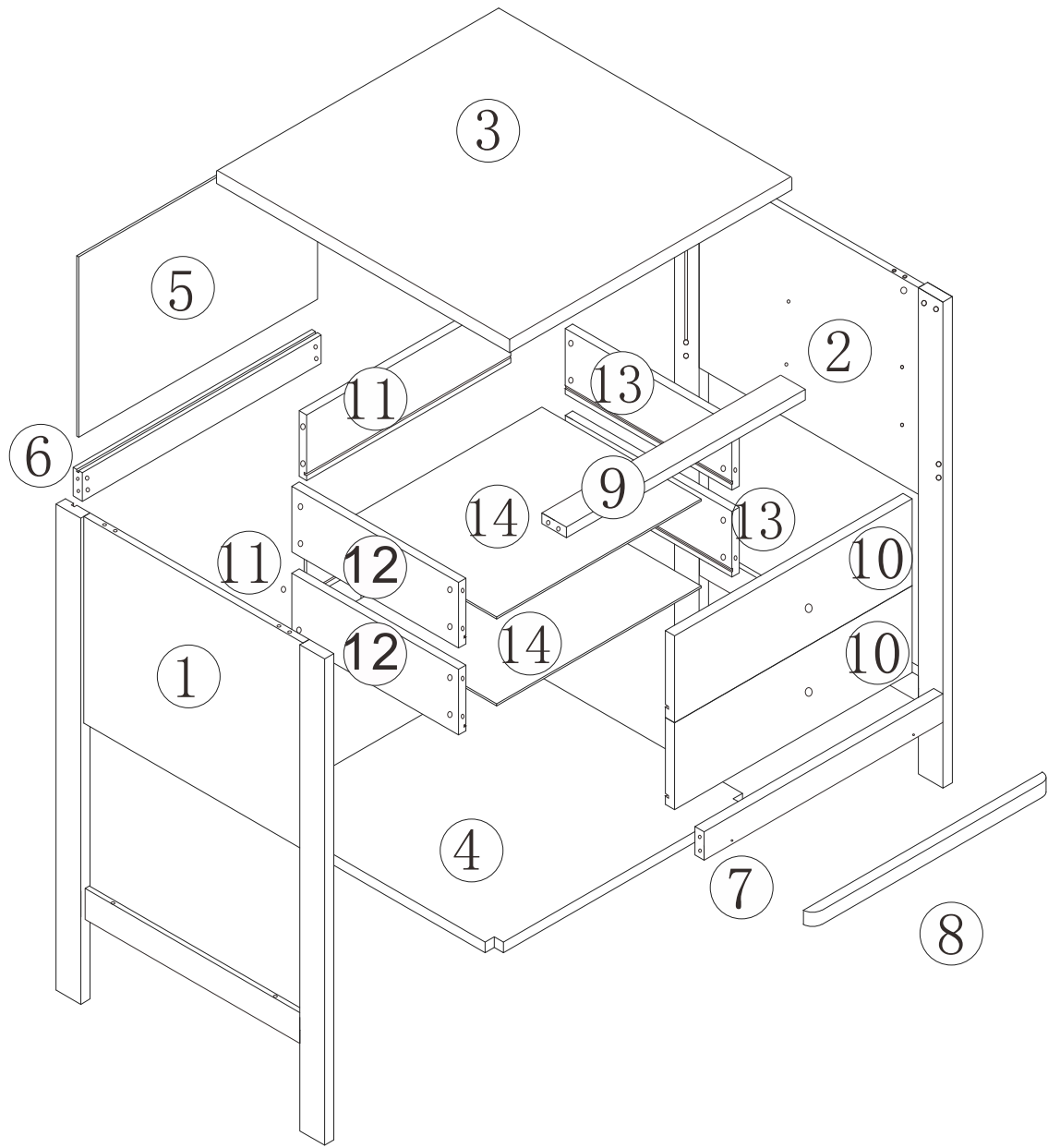

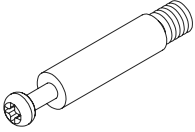
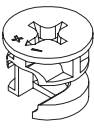
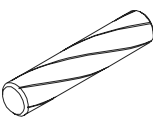
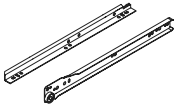
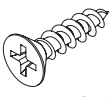

<p>A</p>  <p>20PCS</p>	<p>B</p>  <p>20PCS</p>	<p>C</p>  <p>8PCS</p>	<p>D</p>  <p>2PCS</p>	<p>E</p>  <p><math>\phi 3 \times 12 \text{mm}</math></p> <p>16PCS</p>
<p>F</p>  <p>2PC</p>	<p>G</p>  <p><math>\phi 4 \times 35 \text{mm}</math></p> <p>12PCS</p>	<p>H</p>  <p><math>\phi 4 \times 16 \text{mm}</math></p> <p>2PCS</p>	<p>I</p>  <p><math>\phi 4 \times 25 \text{mm}</math></p> <p>2PCS</p>	<p>J</p>  <p>2PCS</p>

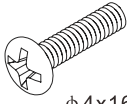
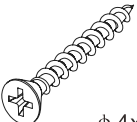
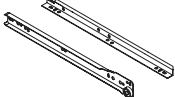
# Assembly Steps (EN) / Montageschritte (DE)

**STEP 1** × 2

• Fix the D/J part to the ⑫/⑬ part with the hardware E.

D x2PCS	E x8PCS	J x2PCS	
---------	---------	---------	--

**STEP 2** × 2

• Fix the ⑫ part to the ⑩ part with the hardware G.  
 • Part ⑩ and part ⑪/⑬ together.  
 • Screw part A and part ⑩ together.  
 • Fix the ⑩ part to the ⑫ part with the hardware B.

A x8PCS	B x8PCS	G x8PCS	
	H x2PCS	F x2PCS	

**STEP 3**

• Fix the D/J part to the ①/② part with the hardware E.

J x2PCS	E x8PCS	D x2PCS	
---------	---------	---------	--

**STEP 4**

• Screw part I and part ⑦/⑧ together.  
 • Fix the ⑦/⑧ part to the ① part with the hardware A/B/C.

A x4PCS	B x4PCS	C x2PCS	I x2PCS
---------	---------	---------	---------

**STEP 5**

• Fix the ② part to the ⑥/⑦/⑨ part with the hardware A/B/C.

A x4PCS	B x4PCS	C x2PCS	
---------	---------	---------	--

**STEP 6**

Assembly Steps (EN) / Montageschritte (DE)

STEP 1

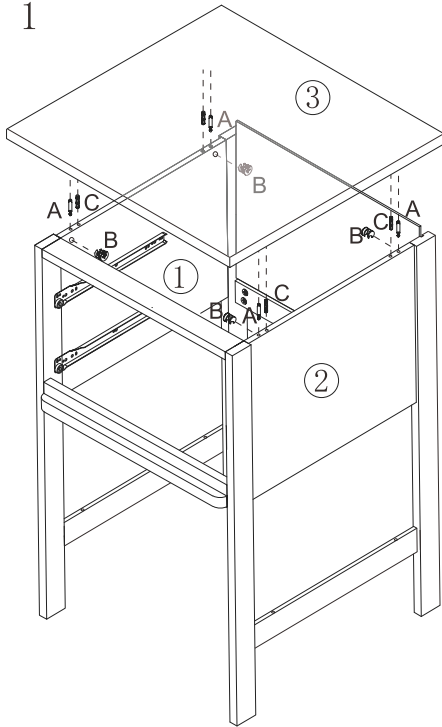

• Fix the ③ part to the ①/② part with the hardware A/B/C.

	A x4PCS
	B x4PCS
	C x4PCS

STEP 2

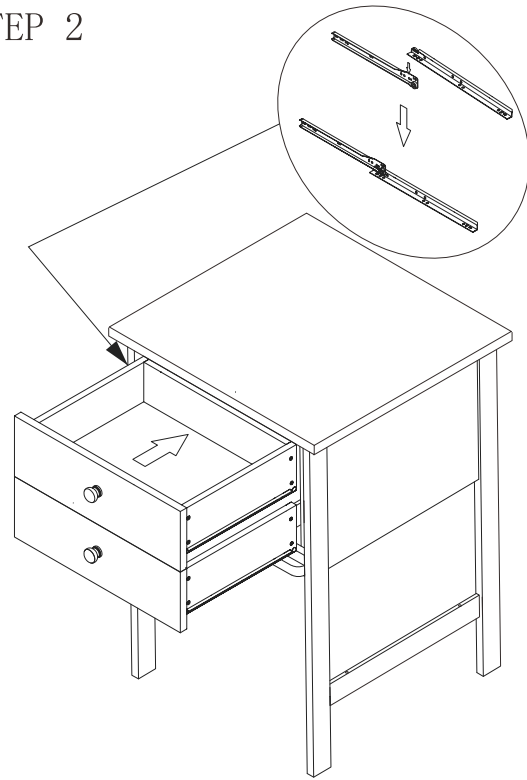

STEP 3

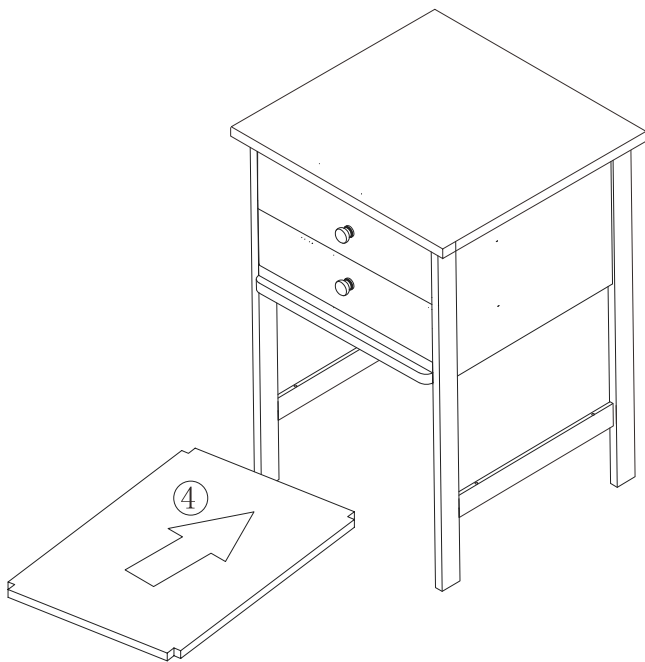

STEP 4

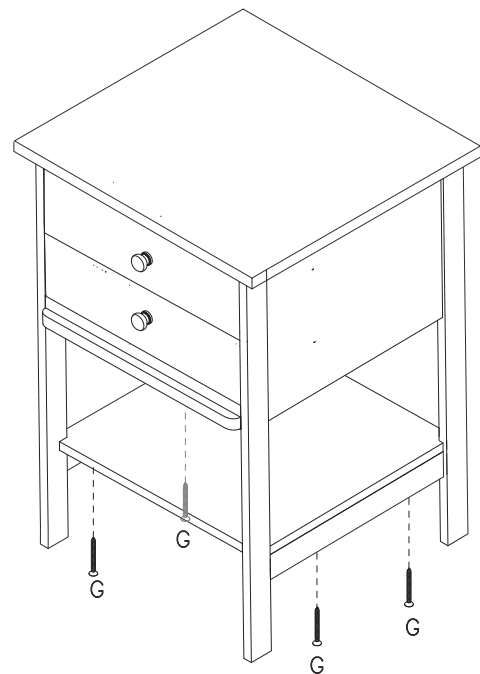

• Fix the ④ part to the ①/② part with the hardware G.

	G x4PCS
--	---------