

WI10299

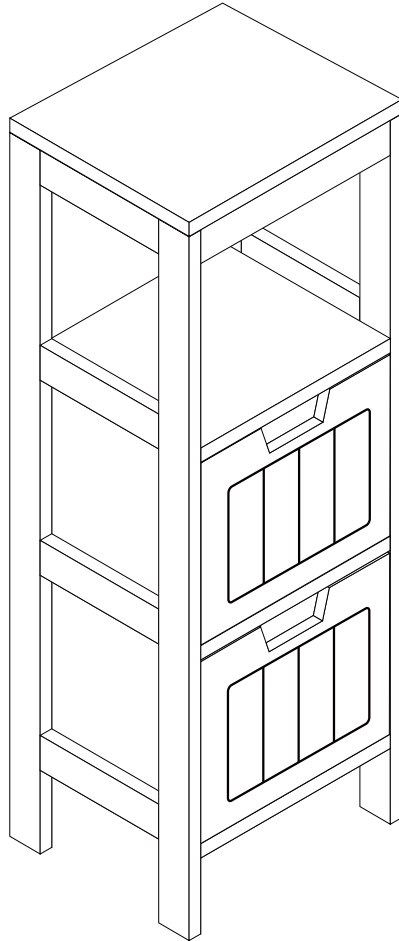

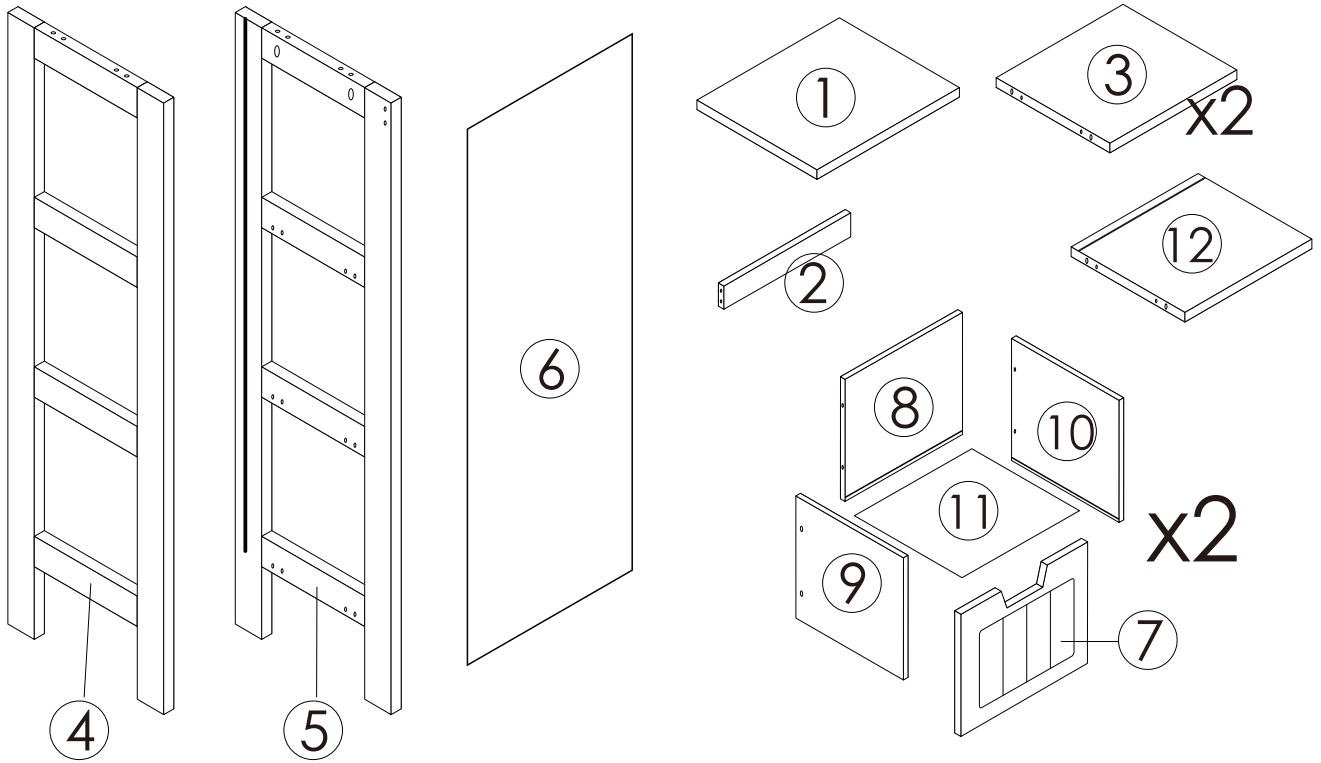
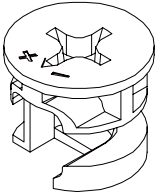
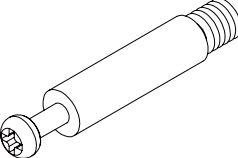
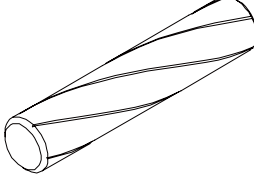
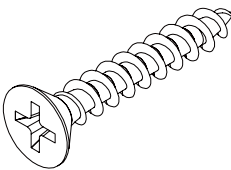
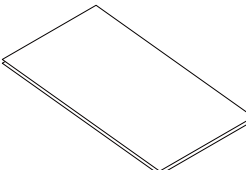

<p>A</p>  <p>24PCS</p>	<p>B</p>  <p>24PCS</p>	<p>C</p>  <p>20PCS</p>
<p>D</p>  <p>8PCS</p>	<p>E</p>  <p>4PCS</p>	

STEP 1

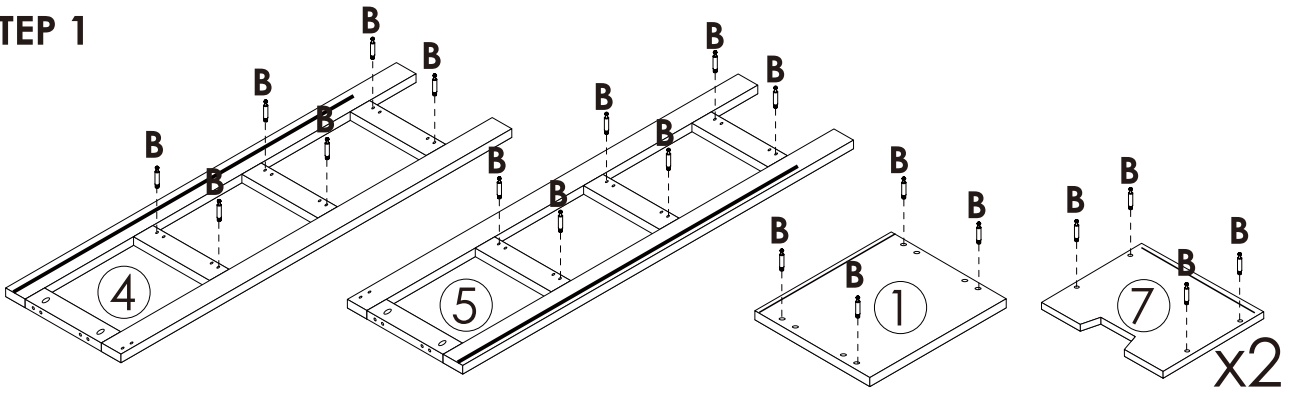

•Screw part B and part ①/④/⑤/⑦ together.

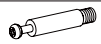

B x24PCS

STEP 2

• Fix the ③/⑫ part to the ⑤ part with the hardware A/C.

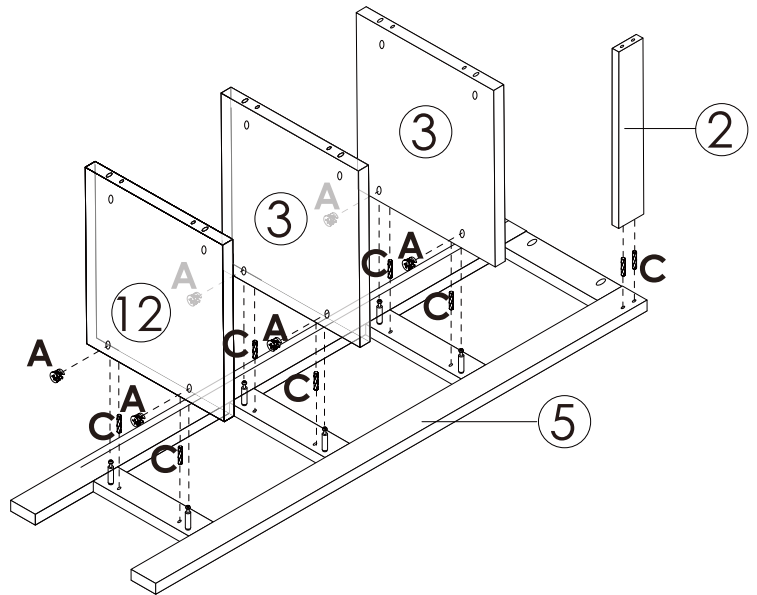

C x8PCS



A x6PCS

STEP 3

• Fix the ⑤ part to the ③/⑫ part with the hardware A/C.

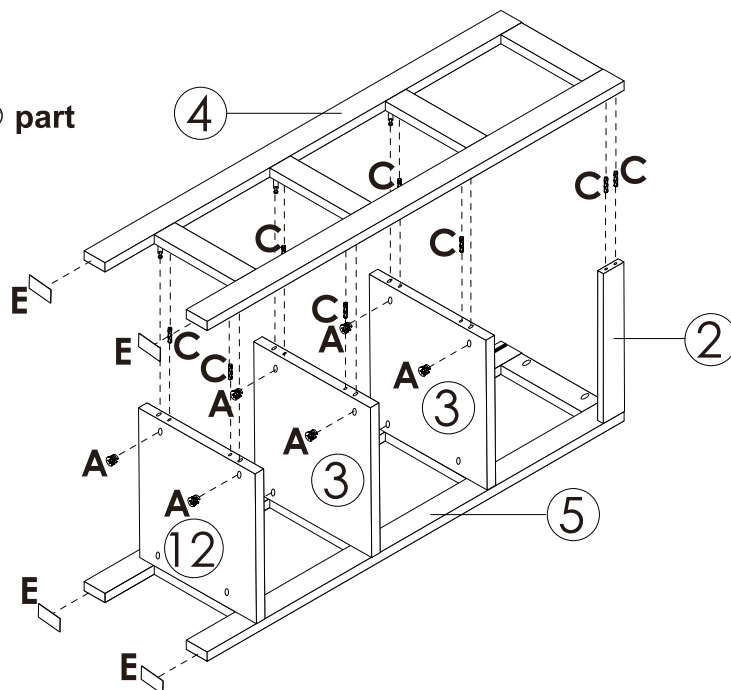

C x8PCS



E x4PCS



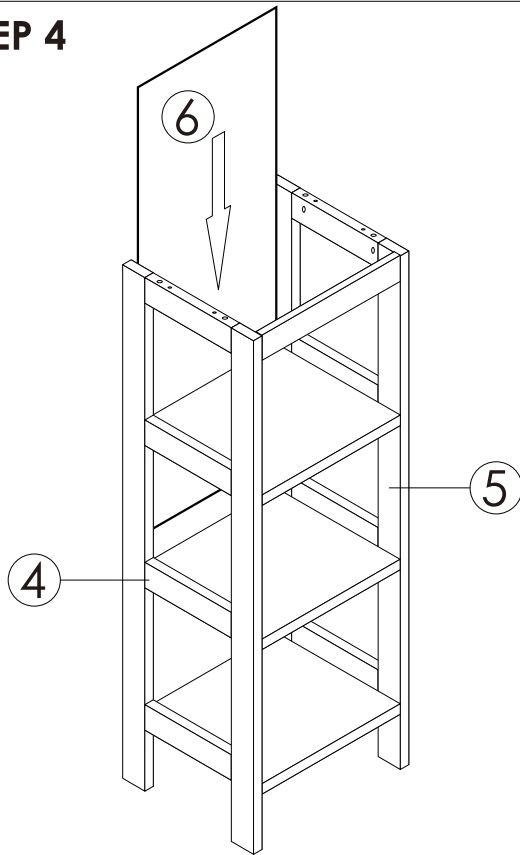

A x6PCS

STEP 4

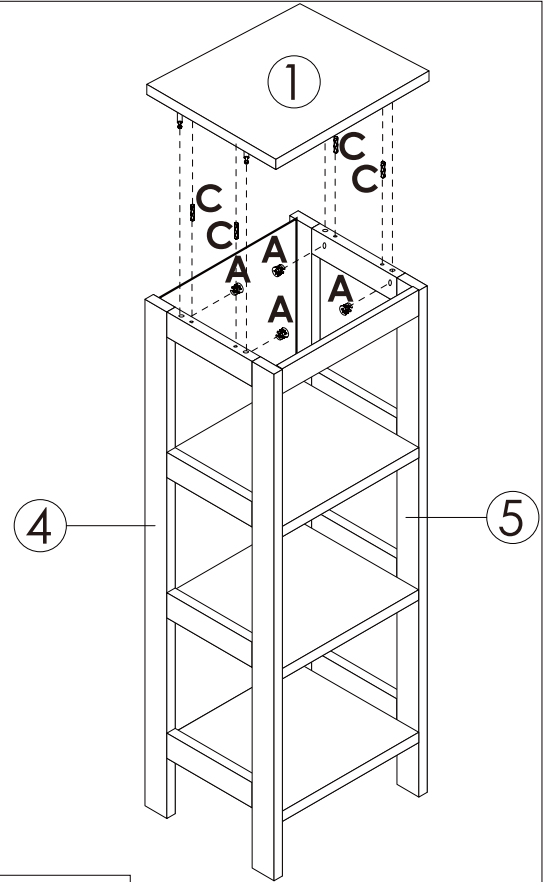

STEP 5





	C x4PCS
	A x4PCS

STEP 6

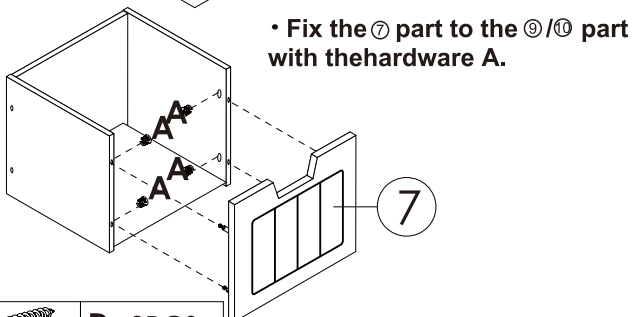
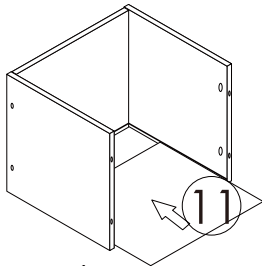
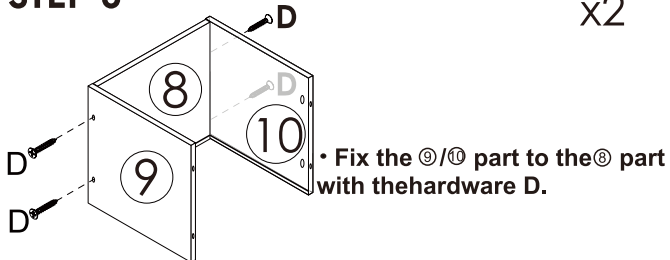
x2



	D x8PCS
	A x8PCS

STEP 7

