

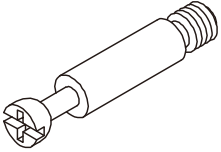







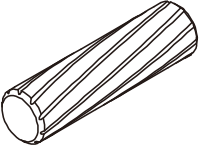
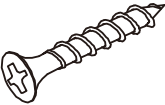

WI9029

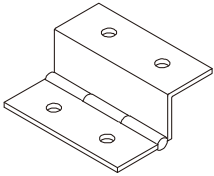

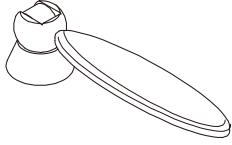
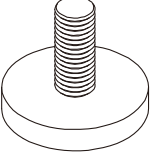
Hardware Included

(H 1)= 14 Screws	(H 2)= 14 Eccentric wheel	(H 3)= 19 Wood Dowels	(H 4)= 3 Screws length	(H 5)= 20 Screws length	(H 6)= 4 Hinge	(H 7)= 2 Door iron sheaf
						
(H 8)= 2 Handle	(H 9)= 4 Foot pad	(H 10)= 2 Anti collapse fabric	(H 11)= 2 Handle Screws	(H 12)= 4 Flat Washers	(H 13)= 2 Plastic expansion pipe	(H 14)= 2 Screws
						
(H 15)= 1 Screw driver (not included)						
						

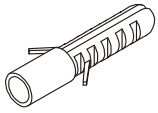
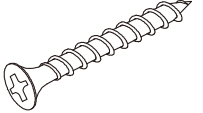
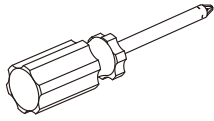
Parts List

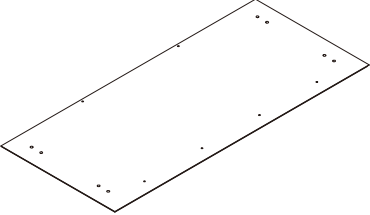
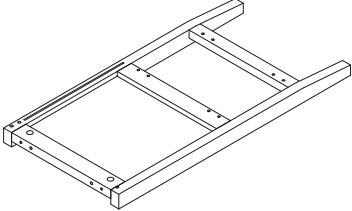
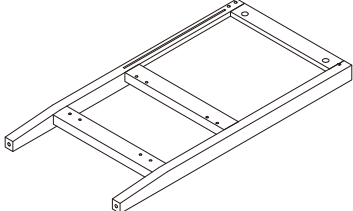
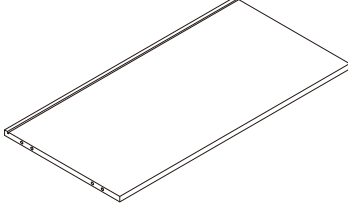
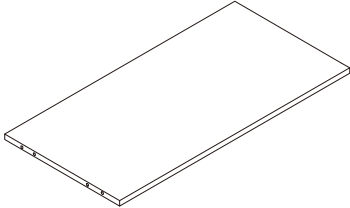
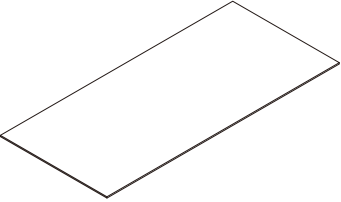
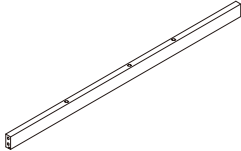
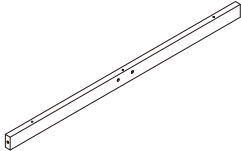
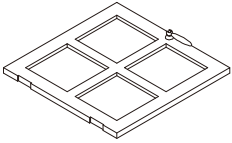
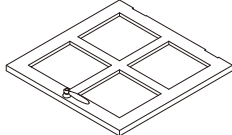
(P1)= 1 Top panel	(P2)= 1 Left side panel	(P3)= 1 Right side panel	(P4)= 1 Shelf	(P5)= 1 Bottom
				
(P6)= 1 Back panel	(P7)= 1 Back apron	(P8)= 1 Front apron	(P9)= 1 Left door	(P10)= 1 Right door
				

Assembly Instructions

Step 1

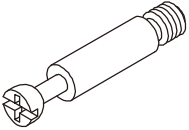
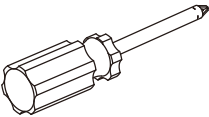

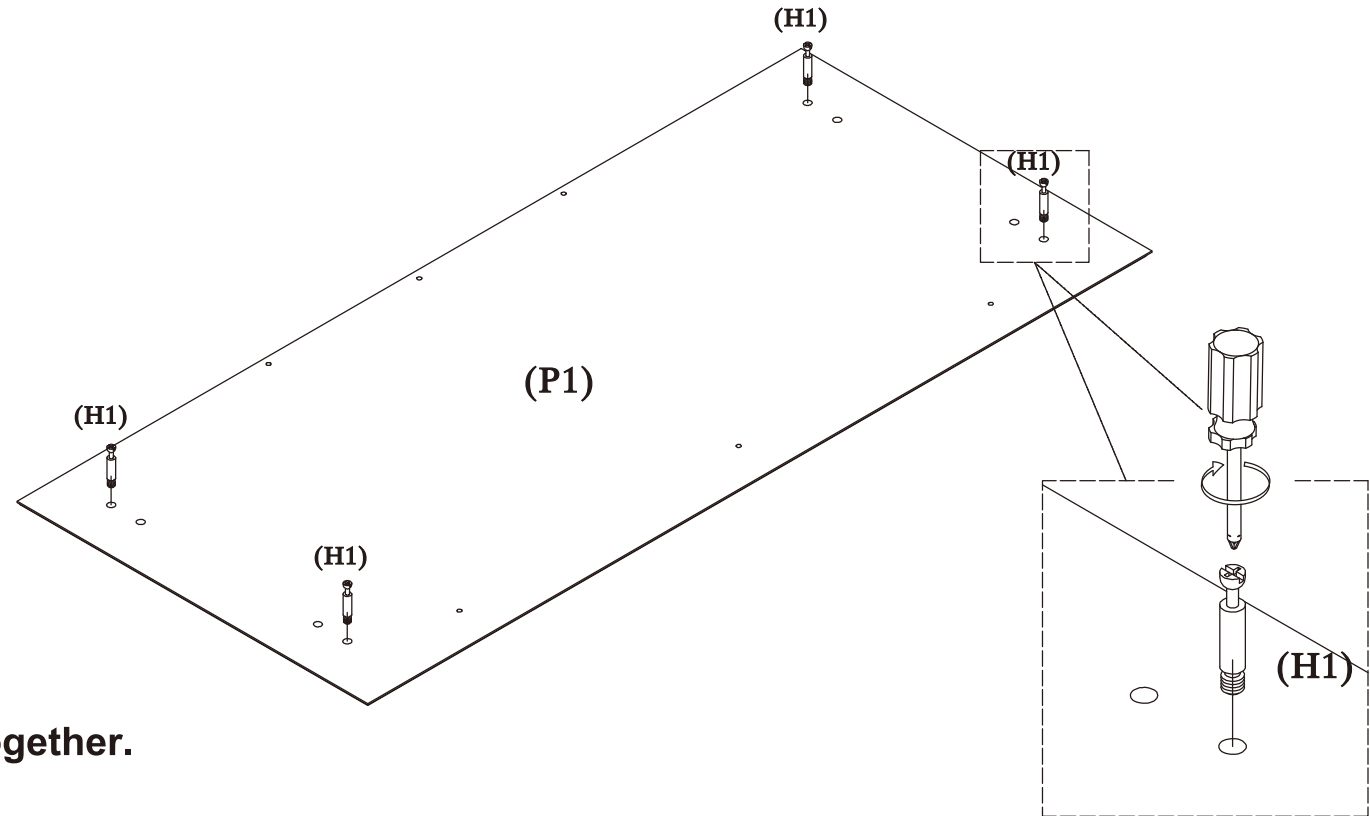
(H1)=4

(H15)=1

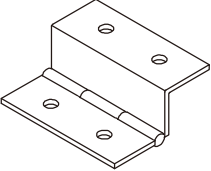

- Screw part H1 and part P1 together.

Assembly Instructions

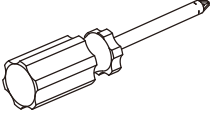
Step 2

(H5)=10	(H6)=4
	
(H7)=2	(H15)=1
	

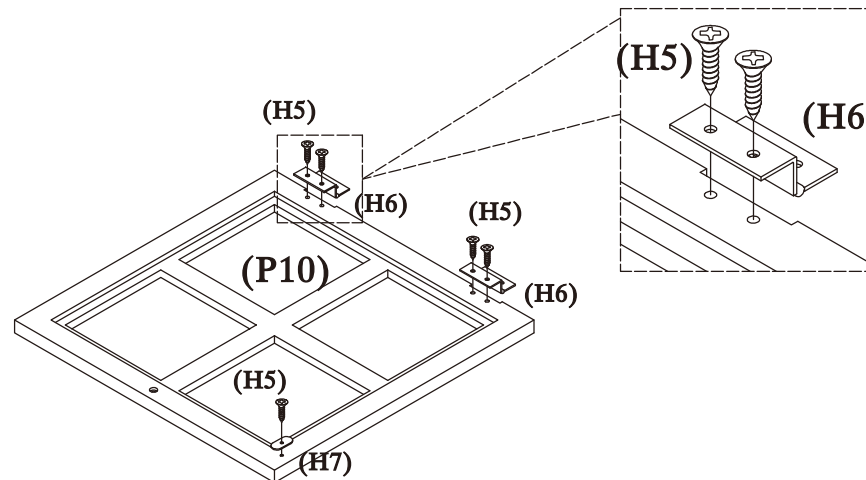
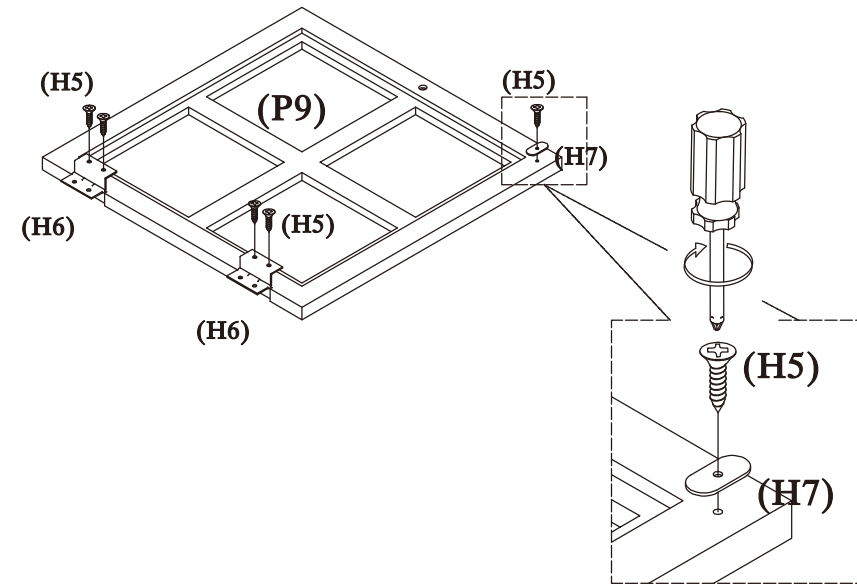

- Screw part H5 and part P9/P10 together.

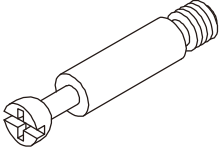
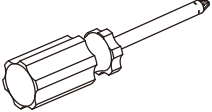
(H 1)= 10

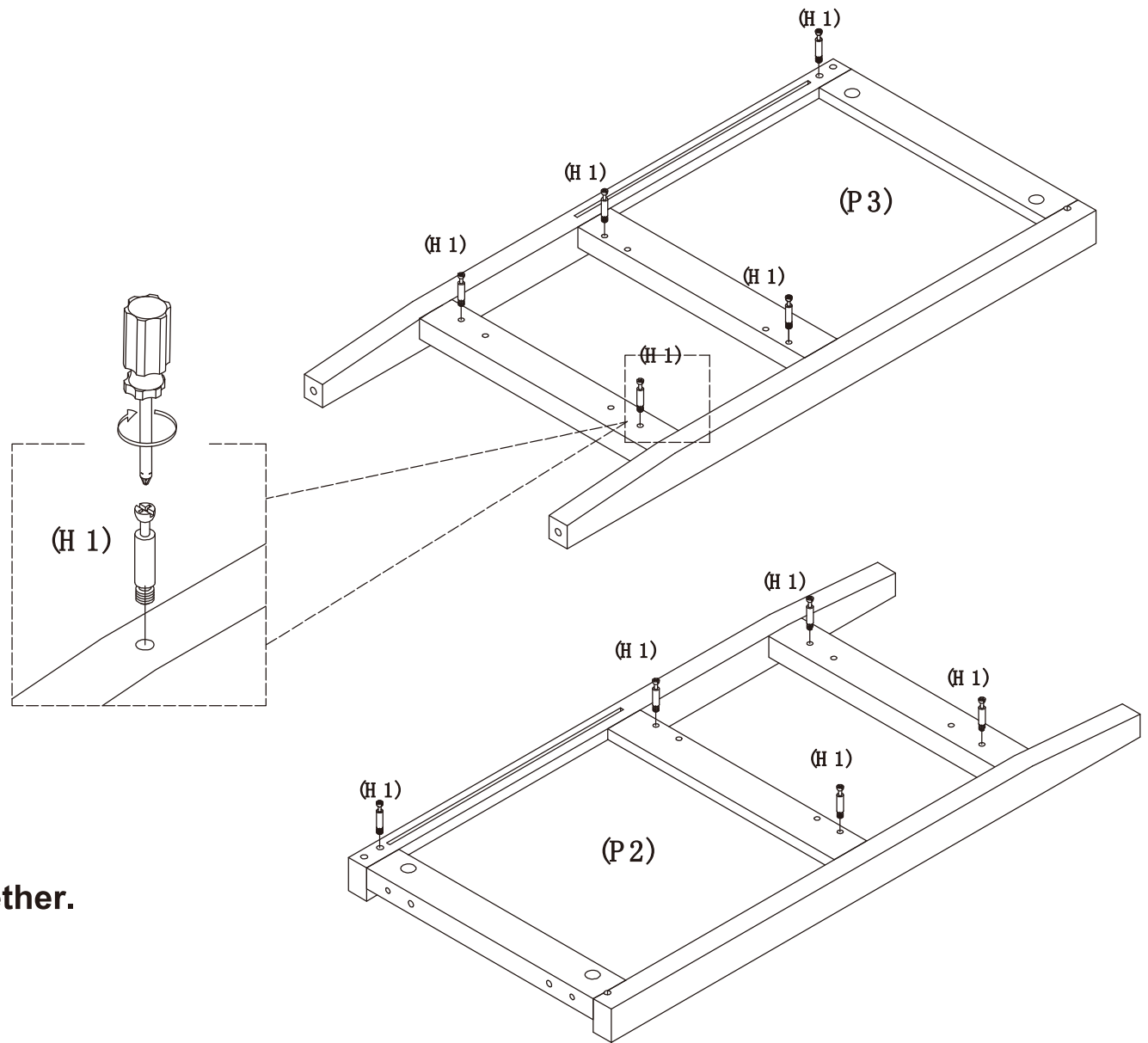
(H 15)= 1

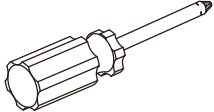
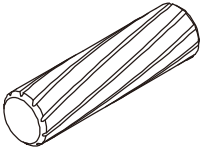

Screw part H1 and part P2/P3 together.

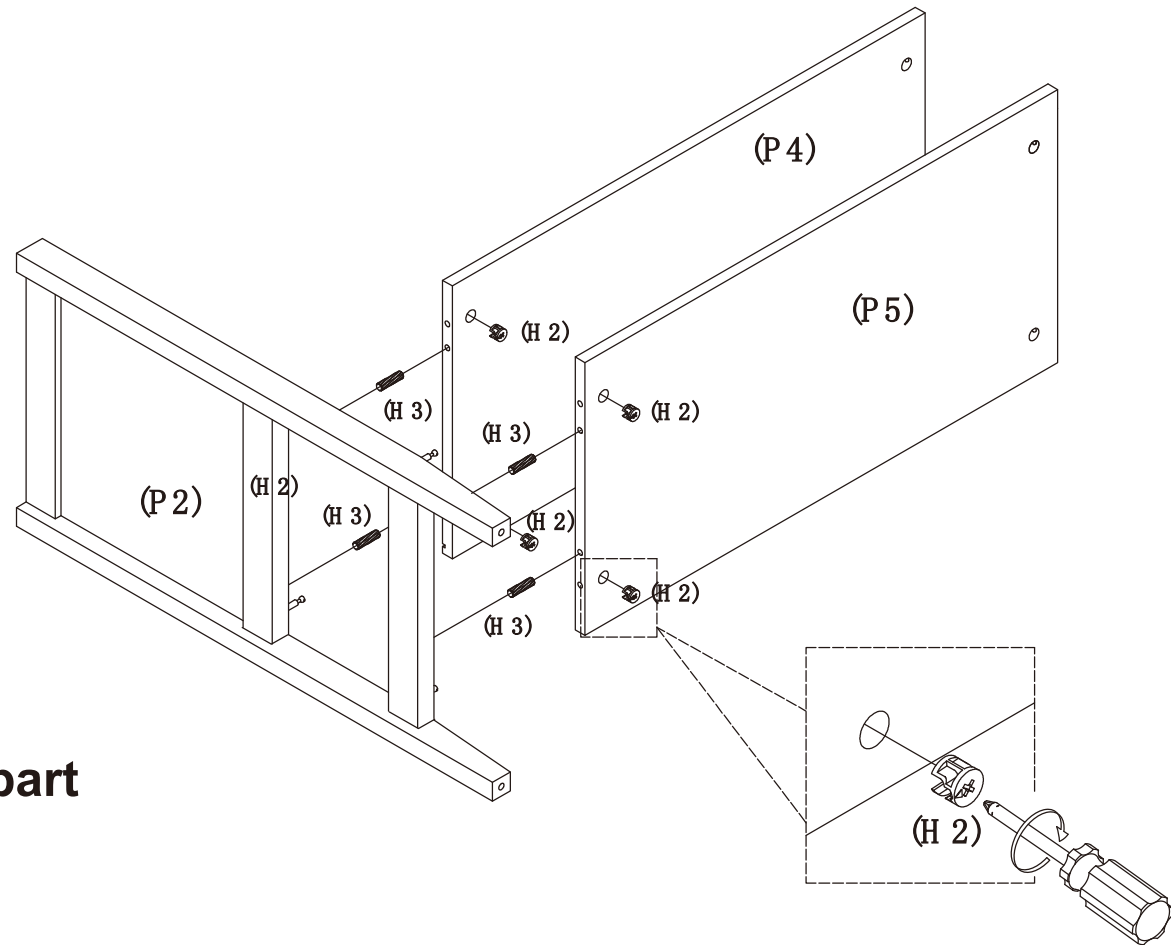
(H 2)= 4	(H 15)= 1
	
(H 3)= 4	
	



· Fix the P5/P4 part to the P2 part with the hardware H2/H3.

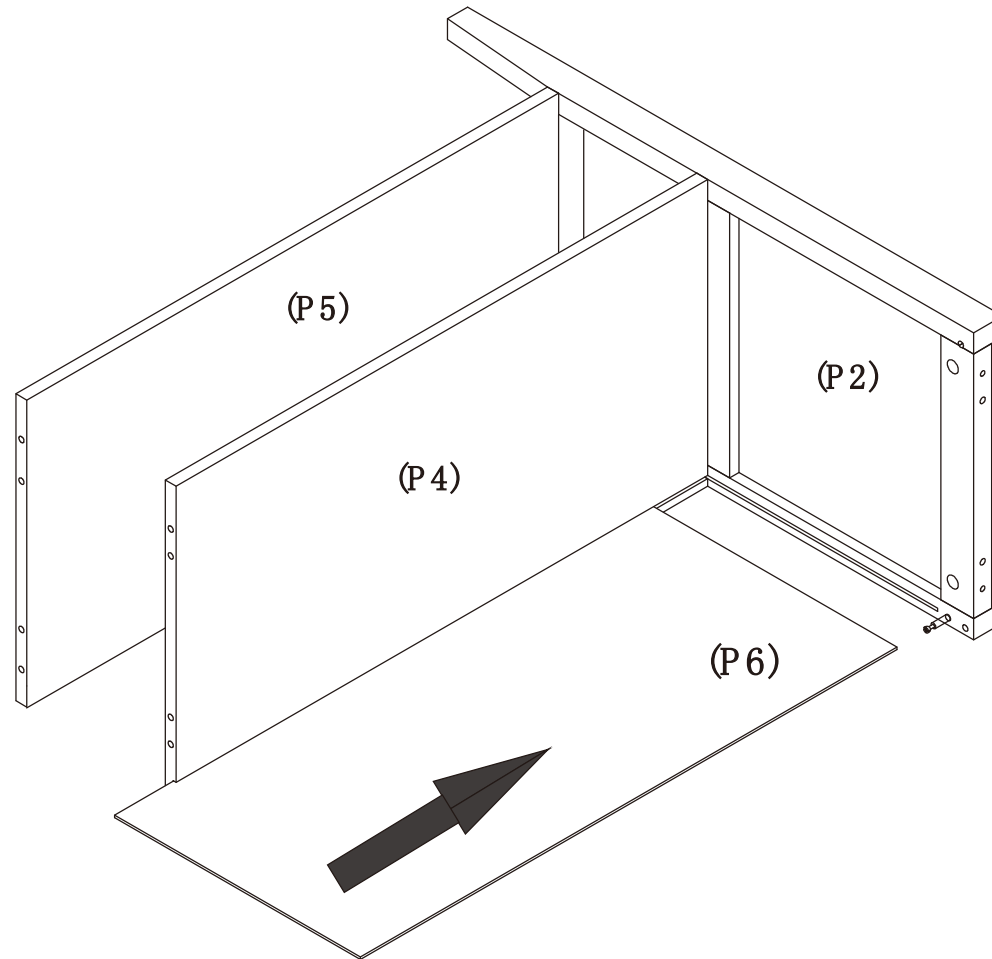

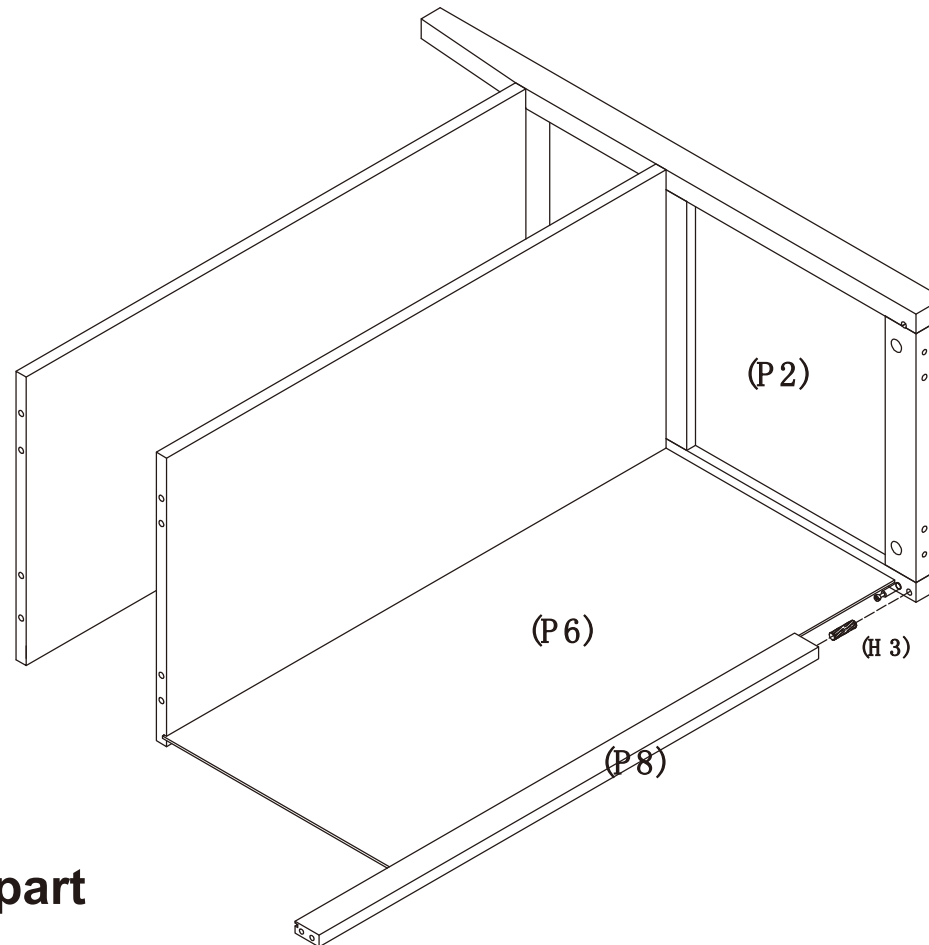
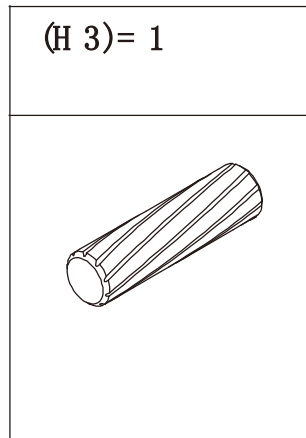

- Fix the P8 part to the P2/P6 part with the hardware H3.

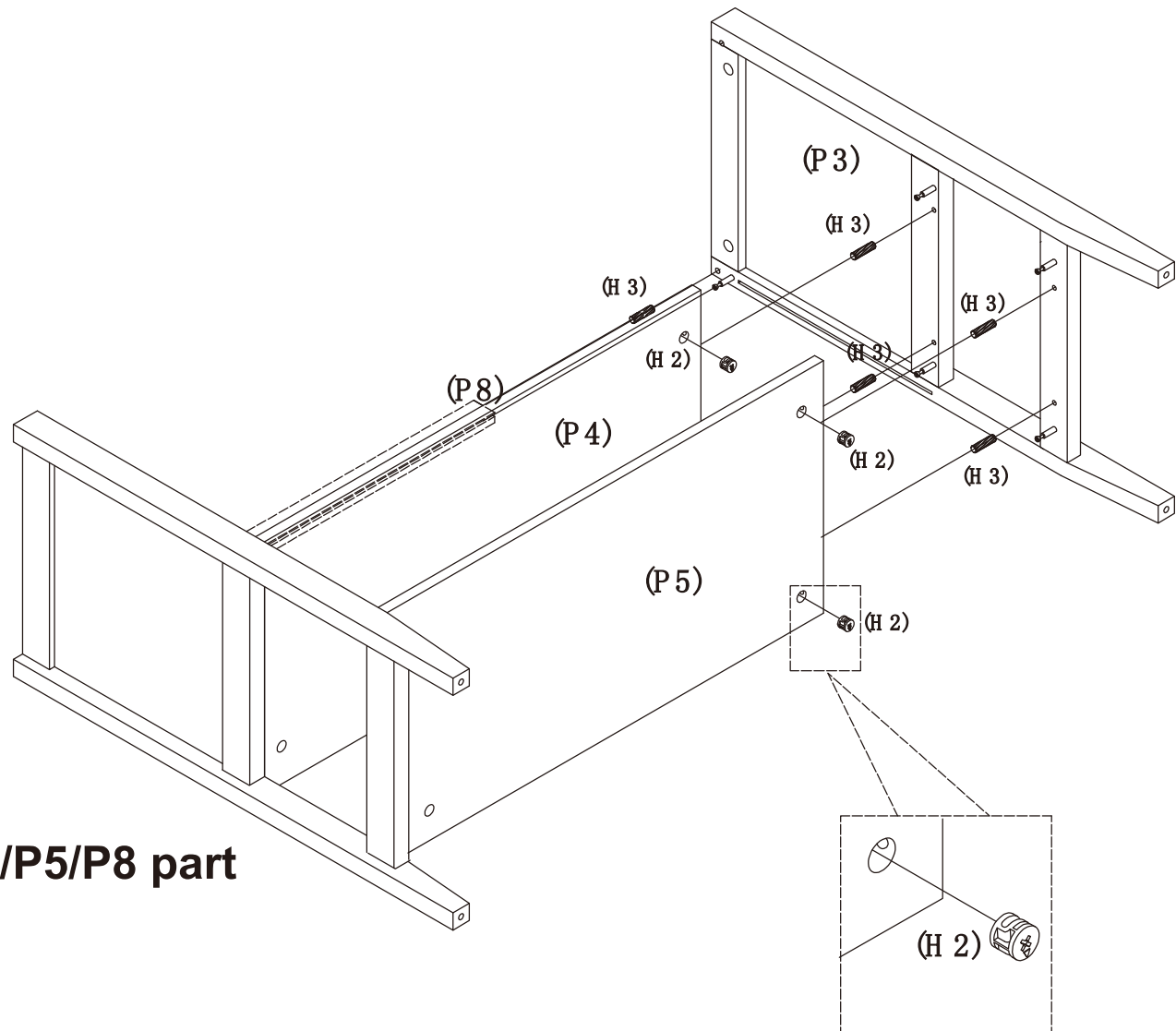
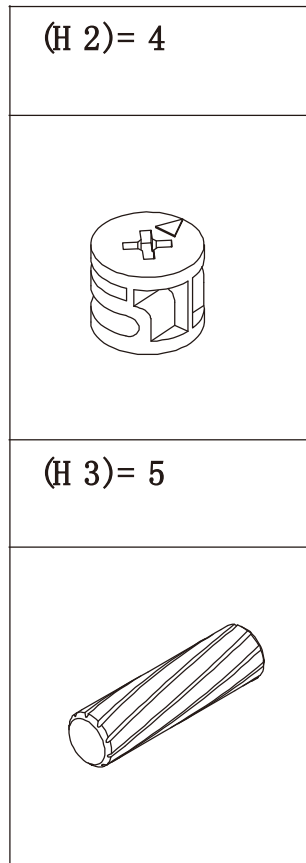

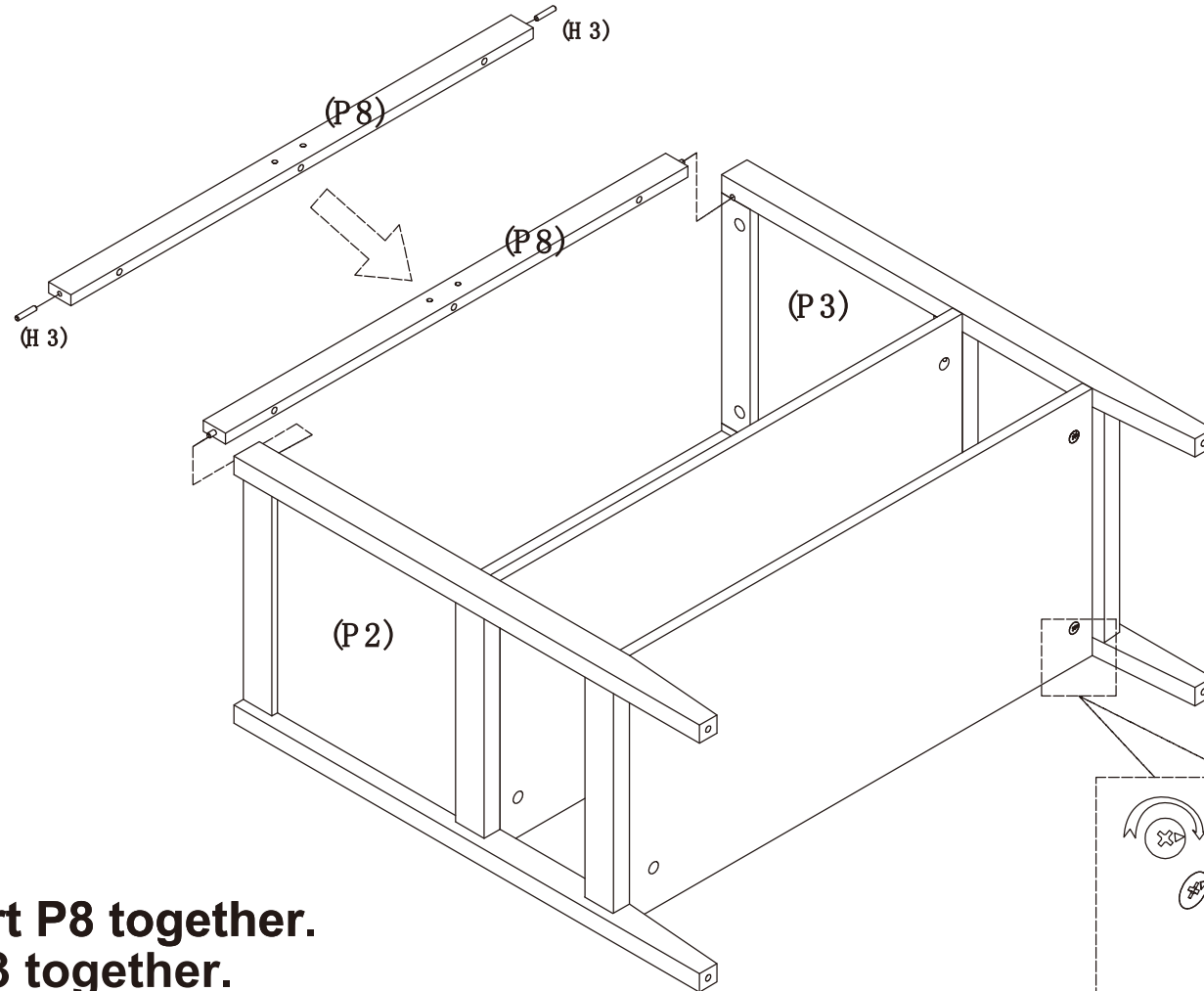
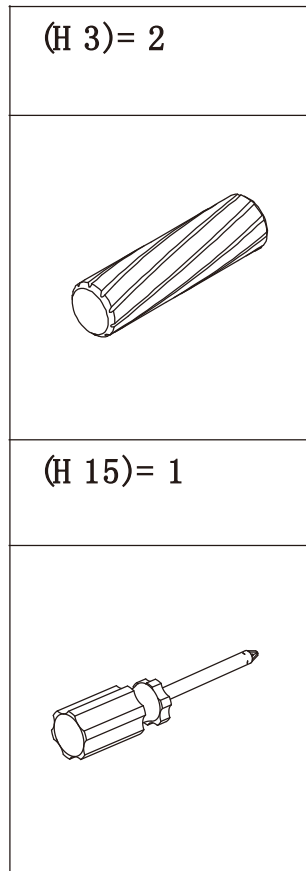

· Fix the P3 part to the P4/P5/P8 part with the hardware H2/H3.

Please do not fully tighten all

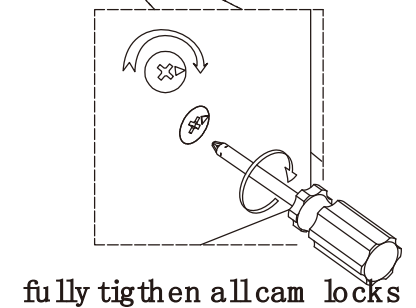

**Screw part H3 and part P8 together.
Part P8 and part P2/P3 together.**

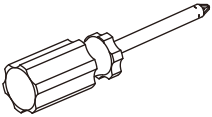
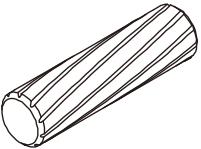

(H2)=4	(H15)=1
	
(H3)=7	
	

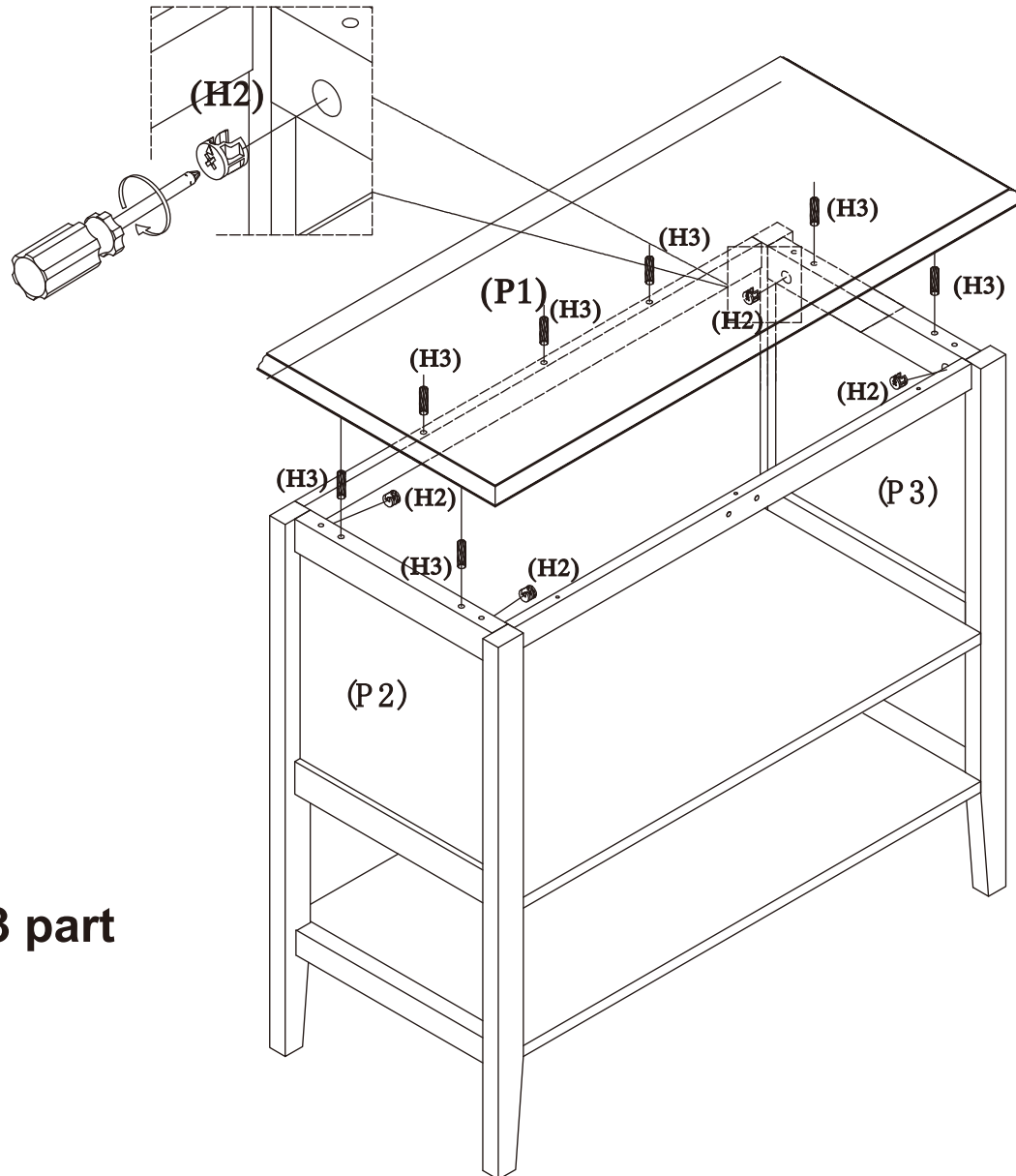

· Fix the P1 part to the P2/P3 part with the hardware H2/H3.

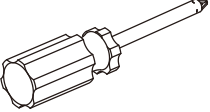
(H2)=2	(H15)=1
	

· **Screw part H2 and part P8 together.**

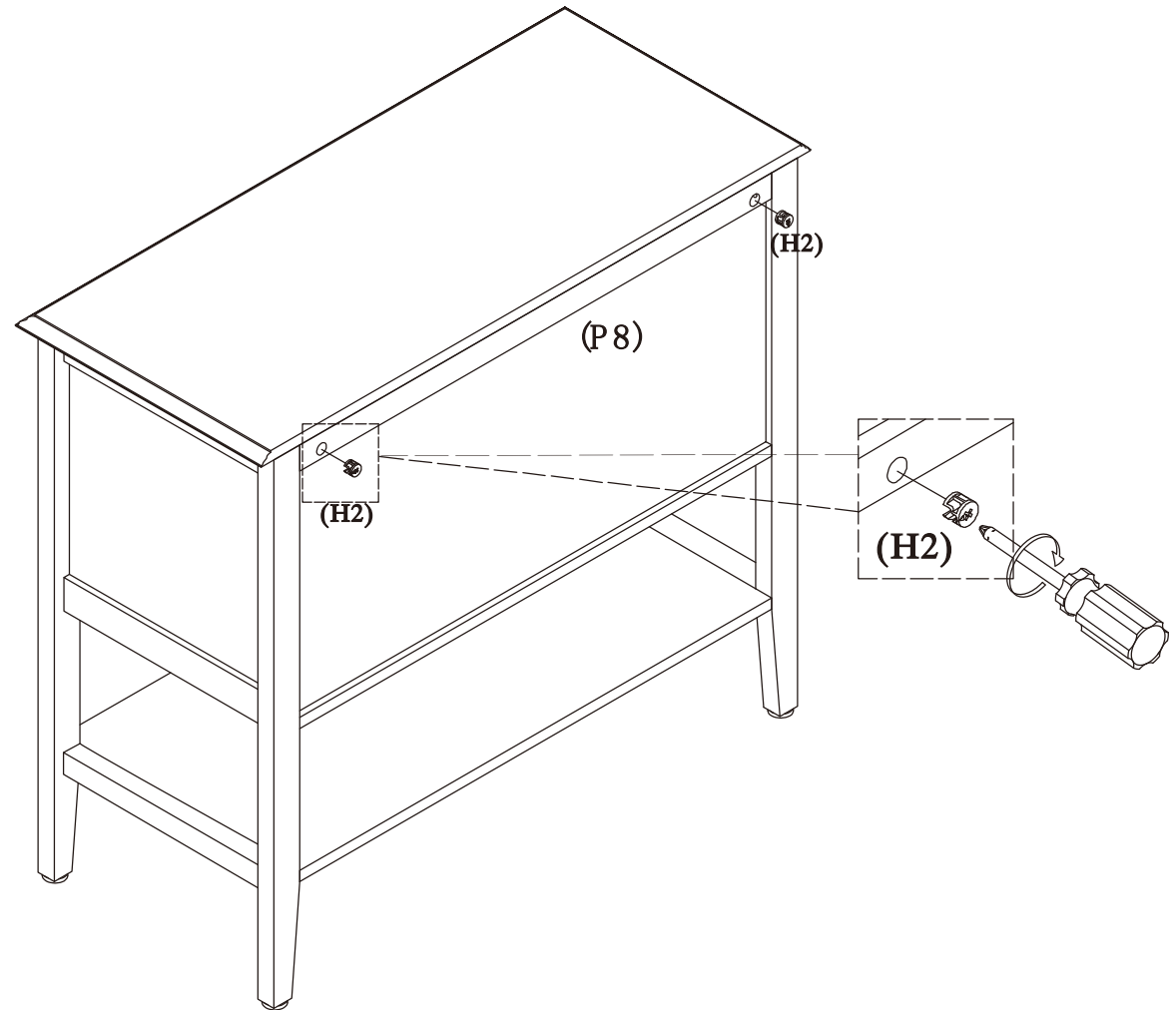

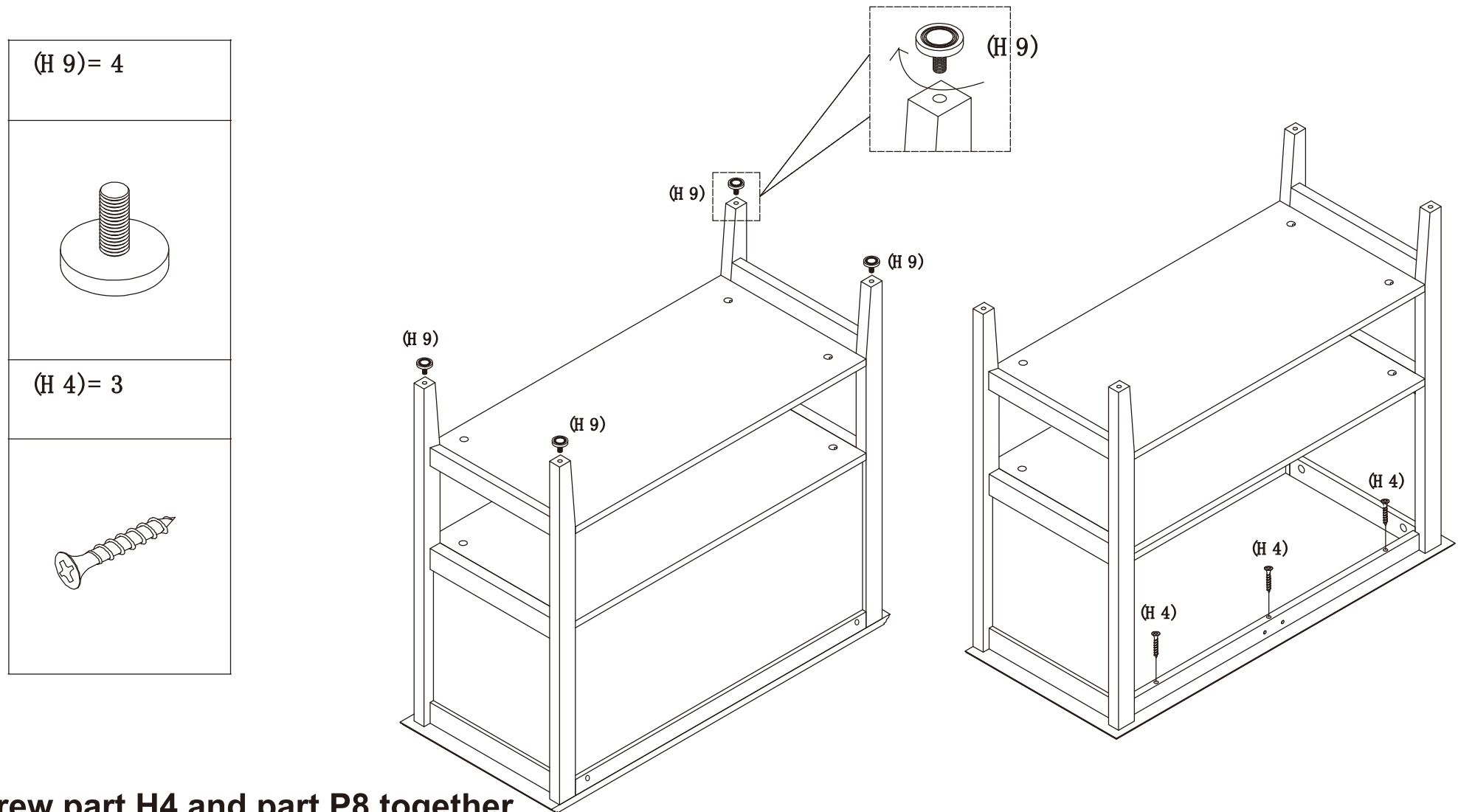



- Screw part H4 and part P8 together.
- part H9 and part P2/P3 together.

Assembly Instructions

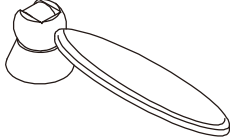
Step 12

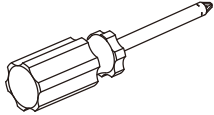

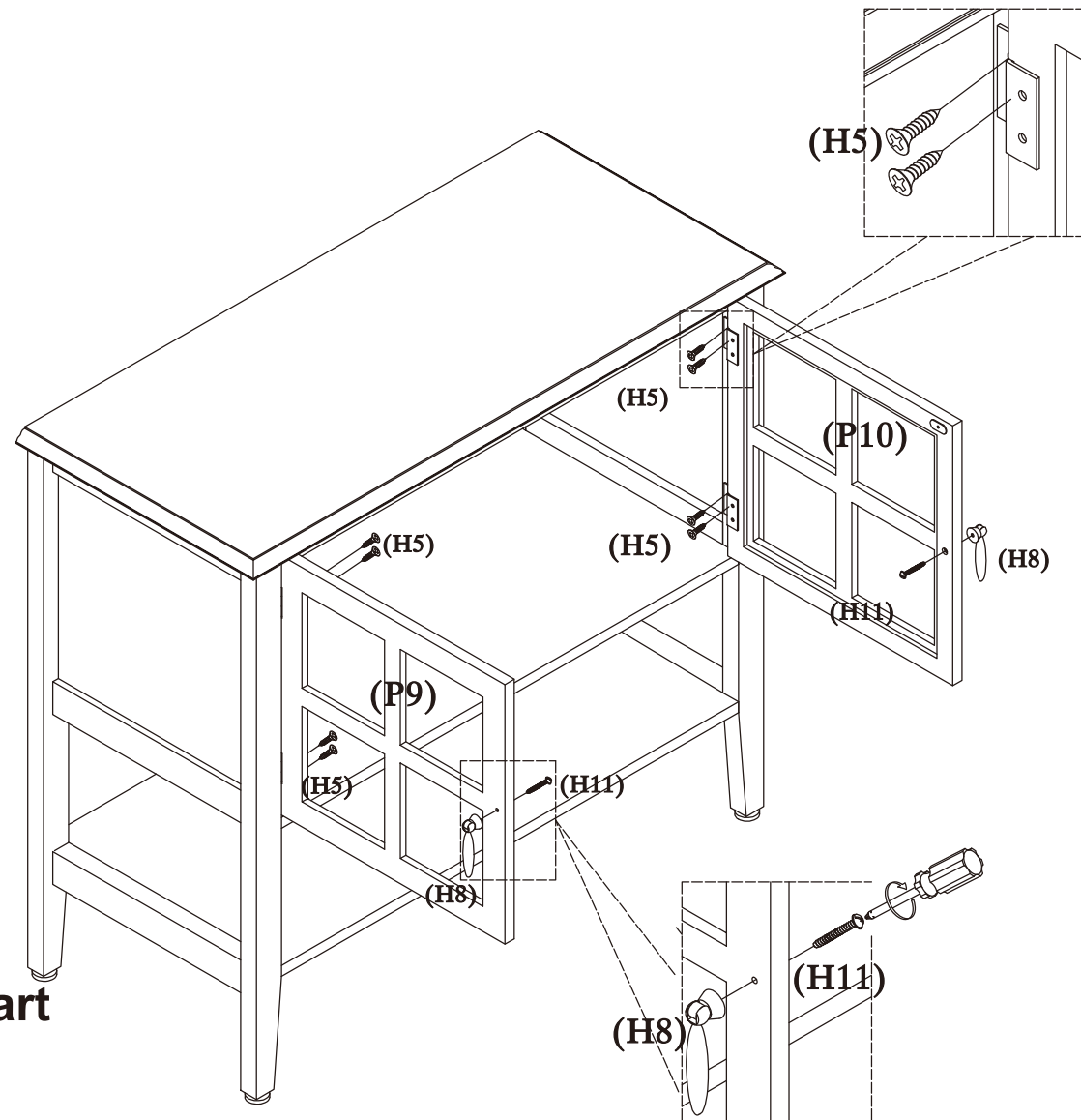

(H5)=10	(H8)=2
	
(H11)=2	(H15)=1
	

- Screw part H11 and part H8 together.
- Fix the P10/P9 part to the P2/P3 part with the hardware H5.

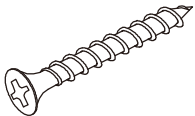

Assembly Instructions

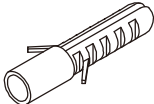
Step 13

(H5)=2	(H14)=2
	
(H12)=4	(H13)=2
	
(H10)=2	
	

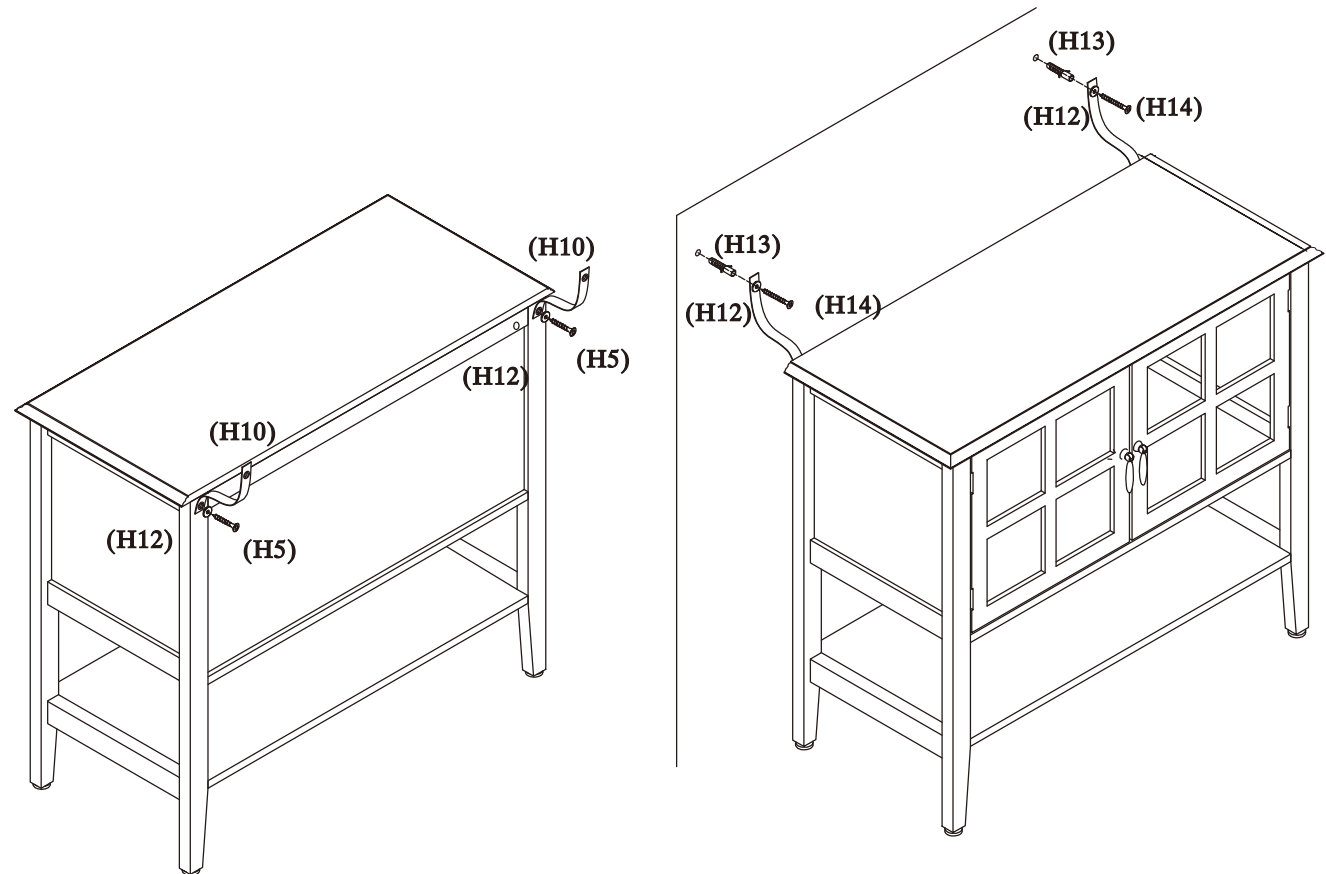

- Screw part H5/H10/H12 and part P2/P3 together.
- Screw part H12/H13/H14 and part Wall together.