





ASSEMBLY INSTRUCTION

MODEL : LW1902-G

PART LIST			
1	Chair Body		1 PC
2	Leg		1 PC
3	Leg		1 PC
4	Corner Block		2 PCS

HARDWARE LIST			
A	JCBC M6 X 60mm		4 PCS
B	Spring Washer M6 X 13mm		4 PCS
C	CSK Screw M4 X 25mm		8 PCS
D	Allen Key		1 PC

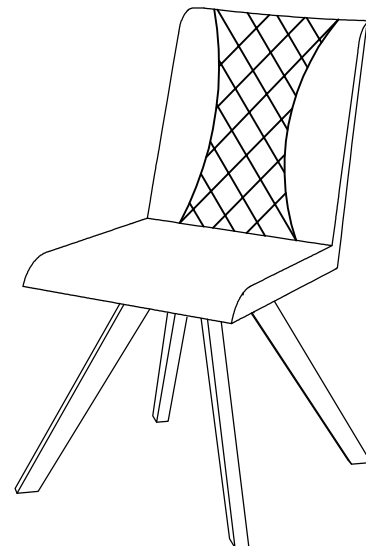

STEP 1
screw in parts # 2 on the seat cushion

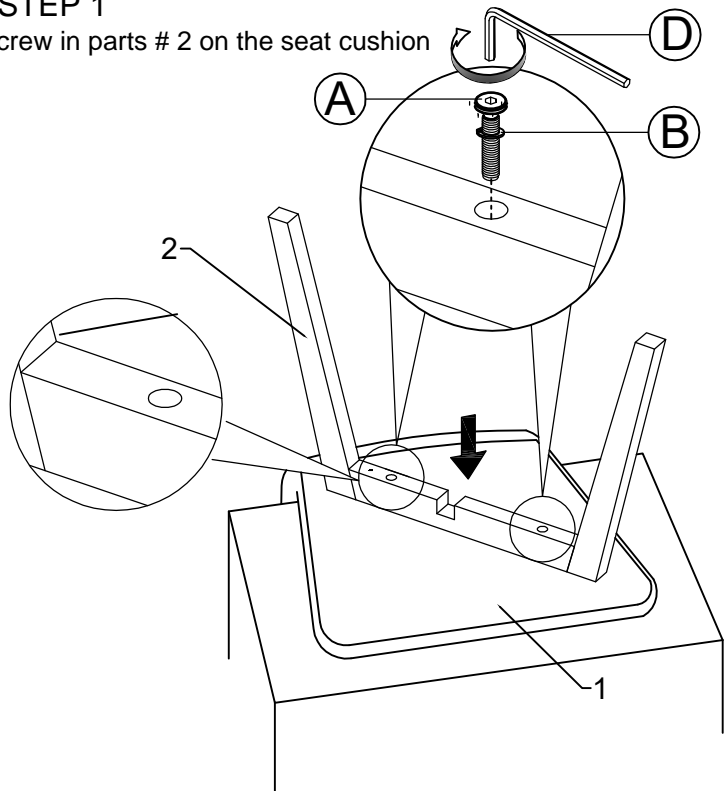

STEP 2
screw in parts # 3 on the seat cushion

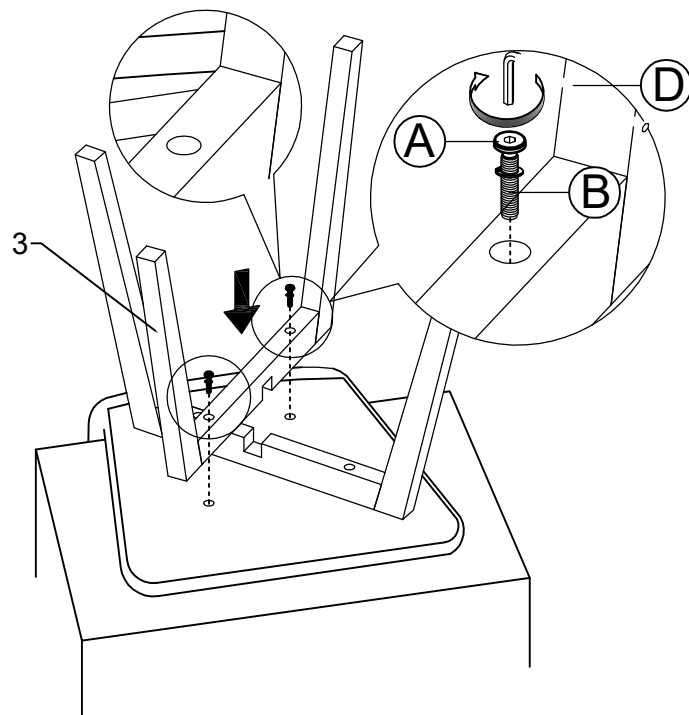

STEP 3
screw in corner blocks on leg

