

0011 King Bed

Assembly Instructions

WII-0619

1 Assembled View

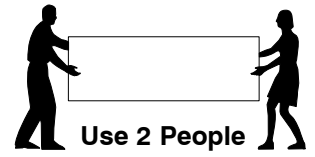
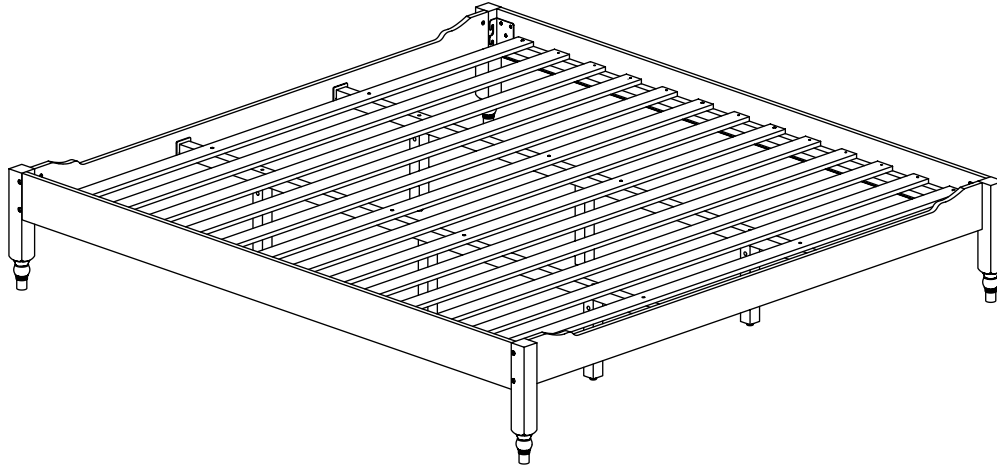

Note: Do not assemble using power tools. This can cause the bolts to be overtightened

2 Parts List

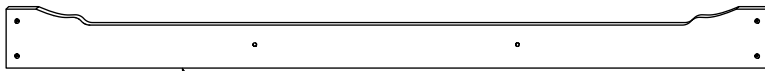

A Head / Footboard Panel x 2

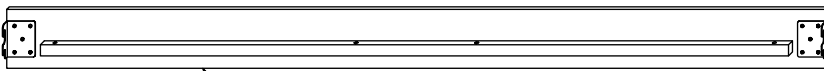

B Side Rail x 2

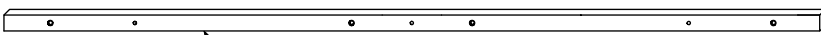

C Long Support x 2



D
Support Leg
x 6

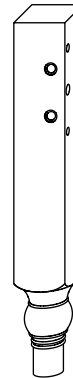

E
Post
(Left hand)
x 2

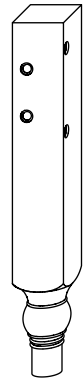

F
Post
(Right hand)
x 2

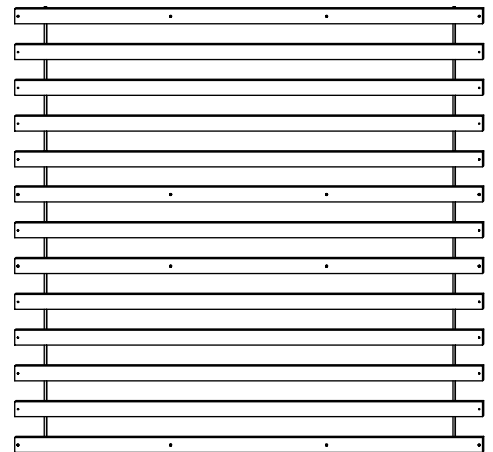

G Set of Bed Slats x 1

0011 King Bed

Assembly Instructions

WII-0619

3 Hardware List



1 M4 Allen Key
x 1

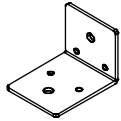

2 Center Rail
Bracket x 4

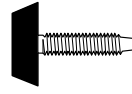

3 Adjustable
Foot x 6

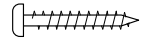

4 Wood Screw
(M4 x 32mm) x 18



5 Wood Dowel
(10 x 40mm) x 4



6 Barrel Nut
x 14



7 Spring Washer
x 8



8 Flat Washer
x 8



9 M6 x 15mm JCB
x 8



10 M6 x 20mm JCB
x 8



11 M6 x 40mm JCB
x 16



12 M6 x 90mm JCB
x 14

4 Assembled the Support Leg (D) to the Long Support (C).

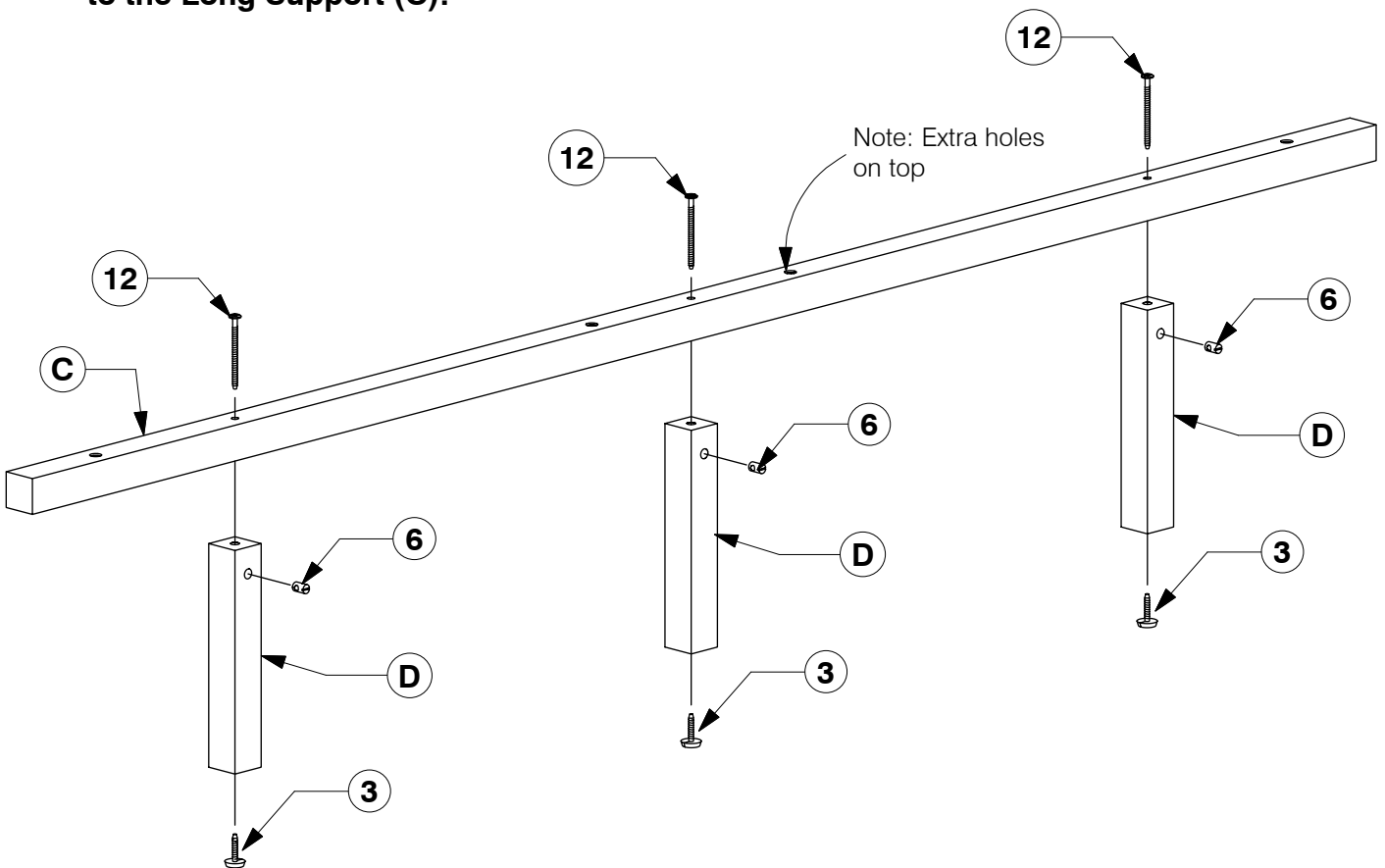

0011 King Bed

Assembly Instructions

W11-0619

- 5 Assemble the Post (E & F) to the Head / Footboard Panel (A).
Fit the Center Rail Bracket to the Head / Footboard Panel (A).**

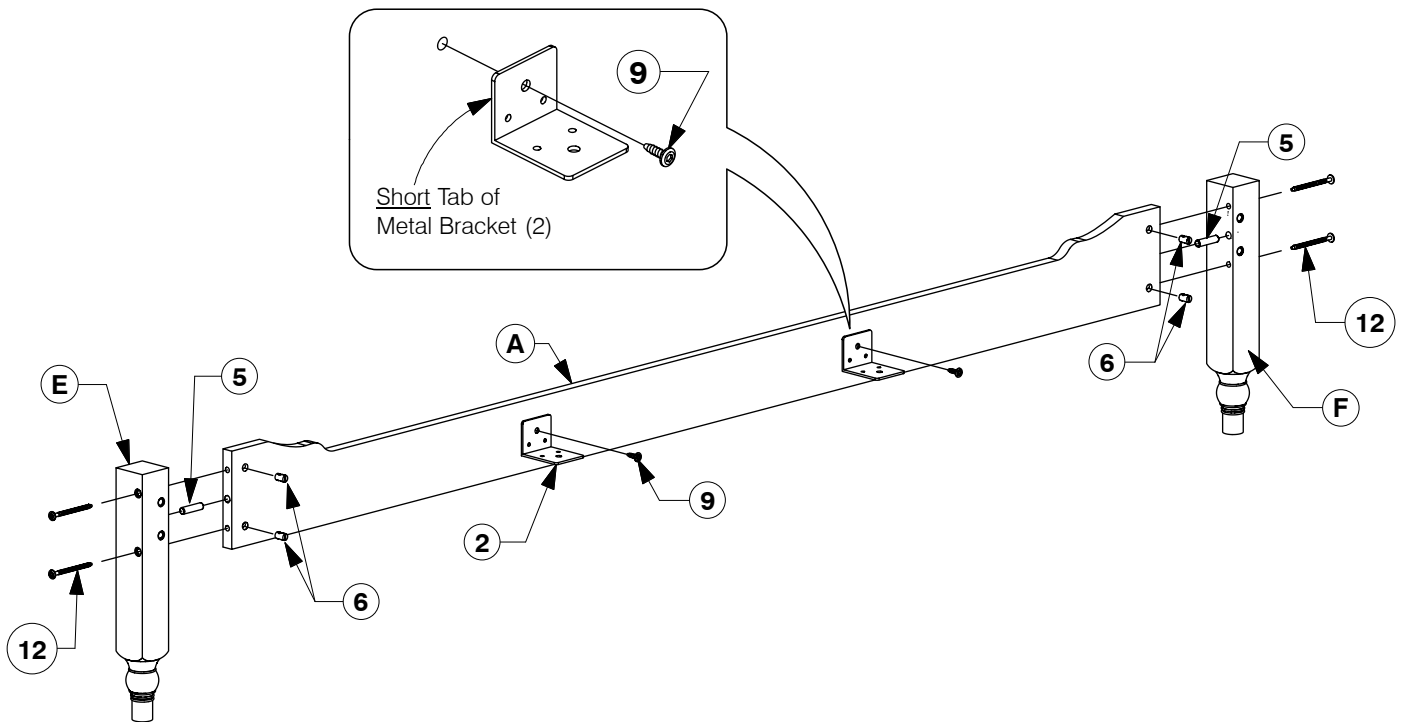

- 6 Assemble the Side Rail (B) to the Headboard / Footboard Panel (A).**

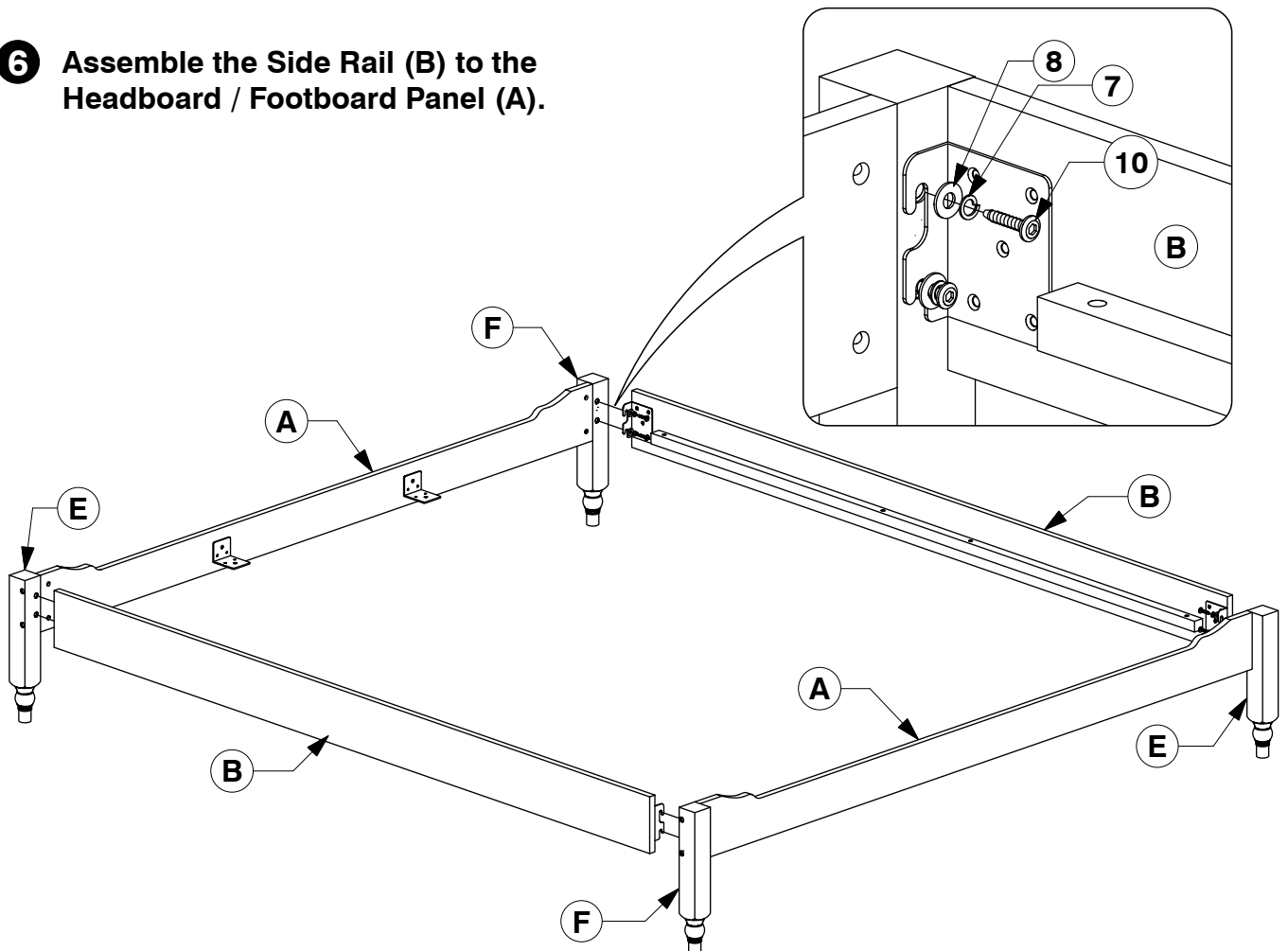

0011 King Bed

Assembly Instructions

W11-0619

- 7 Bolt the Long Support (C) to the Center Rail Brackets (2) on the Headboard / Footboard Panel (A).**

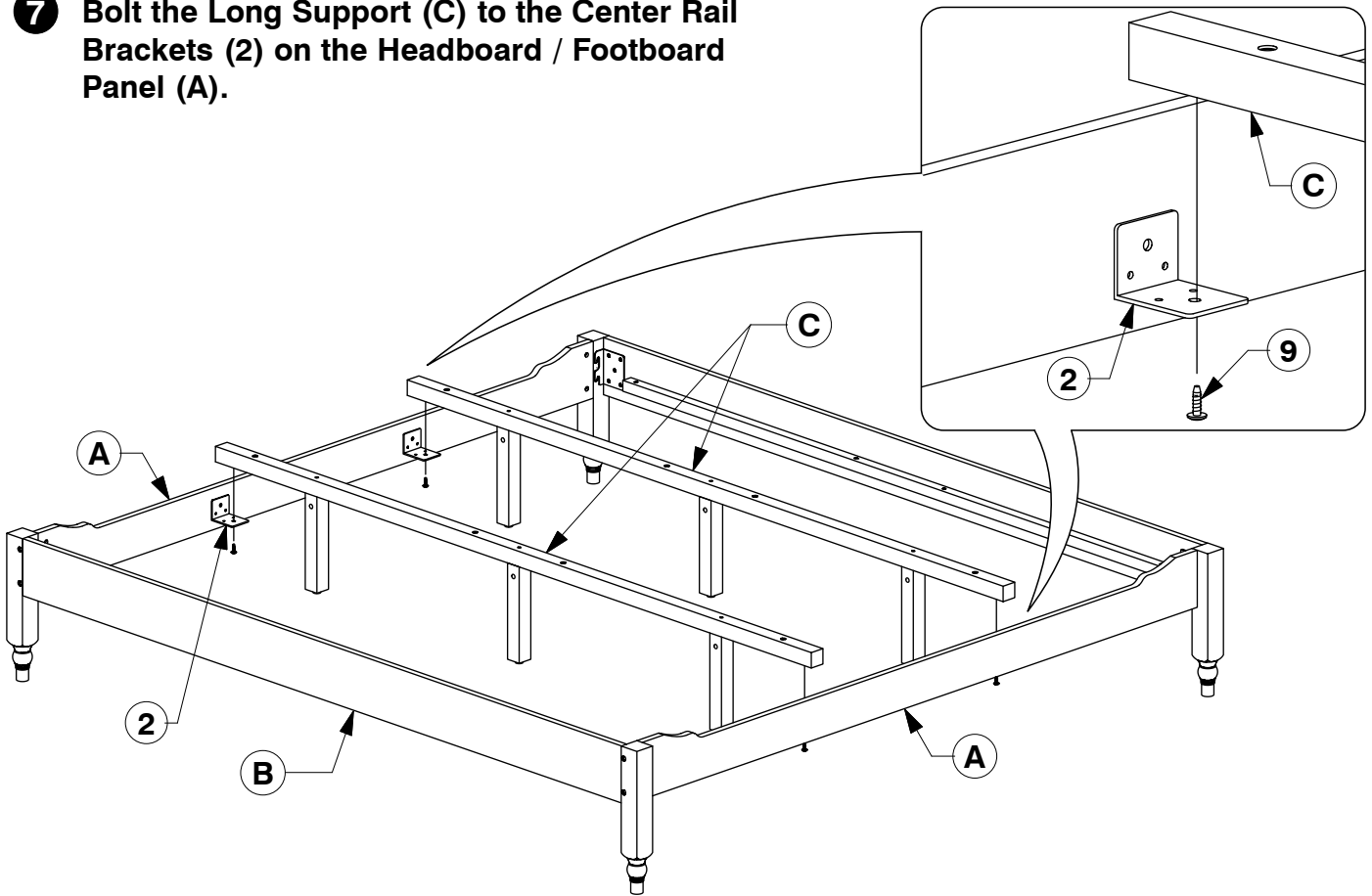

- 8 Bolt & screw the Bed Slats (G) to the Side Rail (B).**

