





















# ASSEMBLY INSTRUCTION

NO	PARTLIST	QTY
1	 HEADBOARD CUSHION	1PC
2	 LEFT HEADBOARD LEG (WITH "L" LABEL)	1PC
3	 RIGHT HEADBOARD LEG (WITH "R" LABEL)	1PC
4	 FOOTBOARD CUSHION	1PC
5	 FOOTBOARD LEG	2PCS
6	 SIDE RAIL	2PCS
7	 SIDE RAIL	2PCS
8	 SIDE RAIL SUPPORT LEG	2PCS
9	 SLAT	4PCS
10	 SUPPORT LEGS WITH ADJUSTABLE FEET	8PCS
ITEM	HARDWARE	QTY
A	 JCBB SCREW M8 x 20MM	8PCS
B	 JCBC SCREW M6 x 25MM	8PCS
C	 JCBC SCREW M6 x 35MM	14PCS
D	 JCBC SCREW M6 x 70MM	2PCS
E	 WOOD DOWEL	2PCS
F	 SPRING WASHER	14PCS
G	 FLAT WASHER	14PCS
H	 SCREW M4 x 32MM	8PCS
I	 L - KEY M5 x 65MM	1PC
J	 L - KEY M4 x 100MM	1PC

## STEP 1

Begin assembly by attaching each Headboard Leg (2) & (3) to the bottom of the Headboard Cushion (1) by aligning the hole and securing with 3 Allen Bolts (C), 3 Spring Washer (F), 3 Flat Washer (G) per leg using L-key (J).

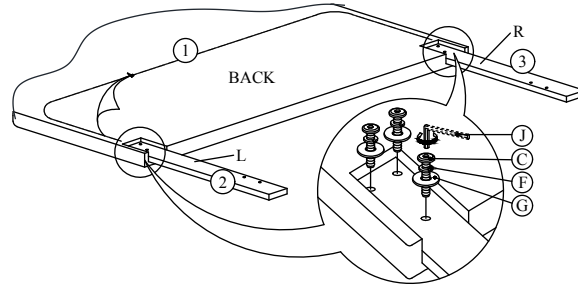

## STEP 2

Attach each Footboard Leg (5) to the bottom of Footboard Cushion (4) by inserting a Dowel (E) & securing with 1 Allen Bolt (D) per leg using L-Key (J).

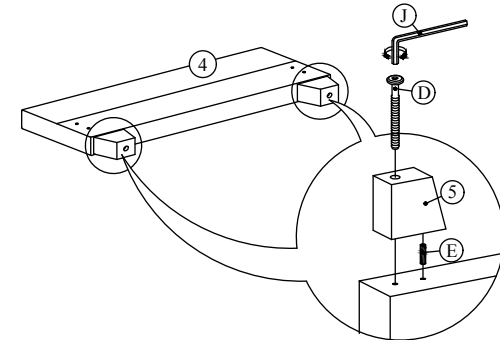

## STEP 3

Attach side rail Support Leg (8) to the join of the Side Rail (6) and Side Rail (7) by securing with 4 Allen Bolts (B), 4 Spring Washer (F), 4 Flat Washer (G) per support using L-Key (J).

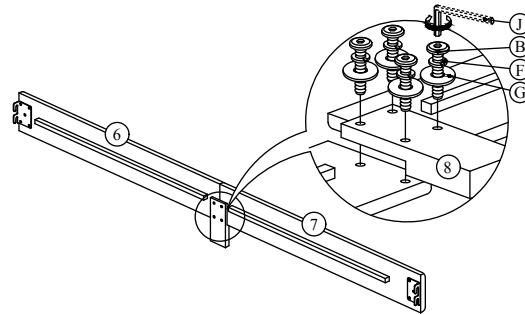

## STEP 4

Attach side rail to the Headboard Leg (2) & (3) and Footboard (4). Aligning holes and securing with 2 Allen Bolts (A) per each by using L-Key (I). (DO NOT FULLY TIGHTEN BOLTS FOR THIS STEP)

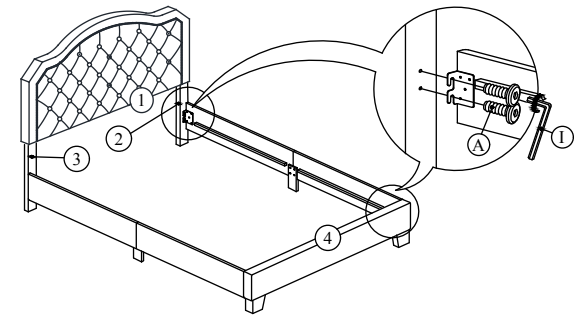

## STEP 5

Attach Support Legs (10) to Slat (9) by securing with 1 Allen Bolt (C) per support. Attach Slats (9) to side rail by securing with 1 Screws (H) per each side. Tighten all screws using philips head screwdriver (NOT INCLUDED). Tighten all bolts on step 2 & 3 using L-Key (J) following step 4 using L-Key (I) that has been provided.

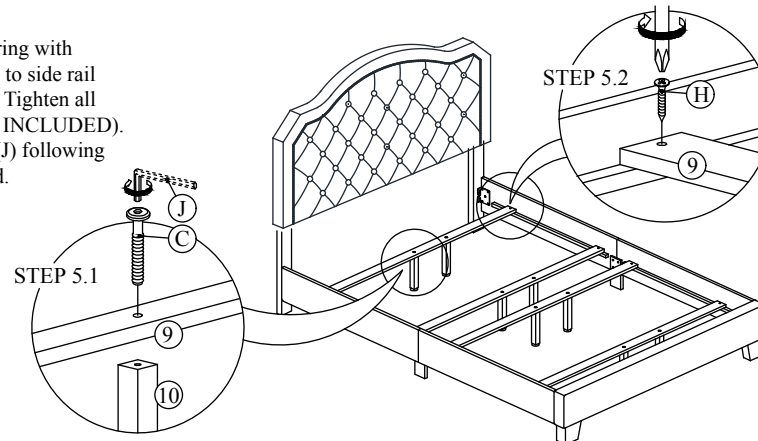

ASSEMBLY COMPLETE

All parts and pieces come zipped inside the headboard