

ASSEMBLY INSTRUCTIONS

Read this instruction carefully. See hardware and furniture part list for guidance. Be sure all parts are complete, before you assemble. Place all wooden furniture parts on a clean and flat soft surface to prevent from being scratched. Follow the figure to start assembling.

CAUTIONS : 1. Do not FULLY - TIGHTEN the nut or nut bolt until all nut or bolt is ready assembled.
2. Do not OVER - TIGHTEN the nut or bolt to avoid causing damages to the thread.
3. Keep all hardware parts out of reach of children.

NOTE : THE LIST AND QUANTITY SHOWN ARE FOR 1 UNIT ASSEMBLY.

Tool needed : Screwdriver & RubberMallet (not provided).

PART LIST		
ITEM	DESCRIPTION	QTY
A	ARM (L/R)	2 PCS
B	FRONT STRETCHER	1 PC
C	BACK STRETCHER	1 PC
D	CENTER RAIL (II)	1 PC
E	CENTER RAIL LEG	1 PC
F	CENTER RAIL (I)	2 PCS
G	CHAIR	1 PC
H	CUSHION BACK	1 PC
I	CUSHION SEAT	3 PCS

HARDWARE LIST		
ITEM	DESCRIPTION	QTY
1	JCBB Bolt M8 x 50mm	4 PCS
2	JCBC Bolt M6 x 50mm	4 PCS
3	WOOD SCREW M4 x38mm	20 PCS
4	M6 SPRING WASHER	4 PCS
5	M8 SPRING WASHER	4 PCS
6	WOOD DOWEL M10 x 30mm	12 PCS
7	M4 ALLEN KEY (BALL SHAPE)	1 PC
8	M5 ALLEN KEY (BALL SHAPE)	1 PC

STEP 1

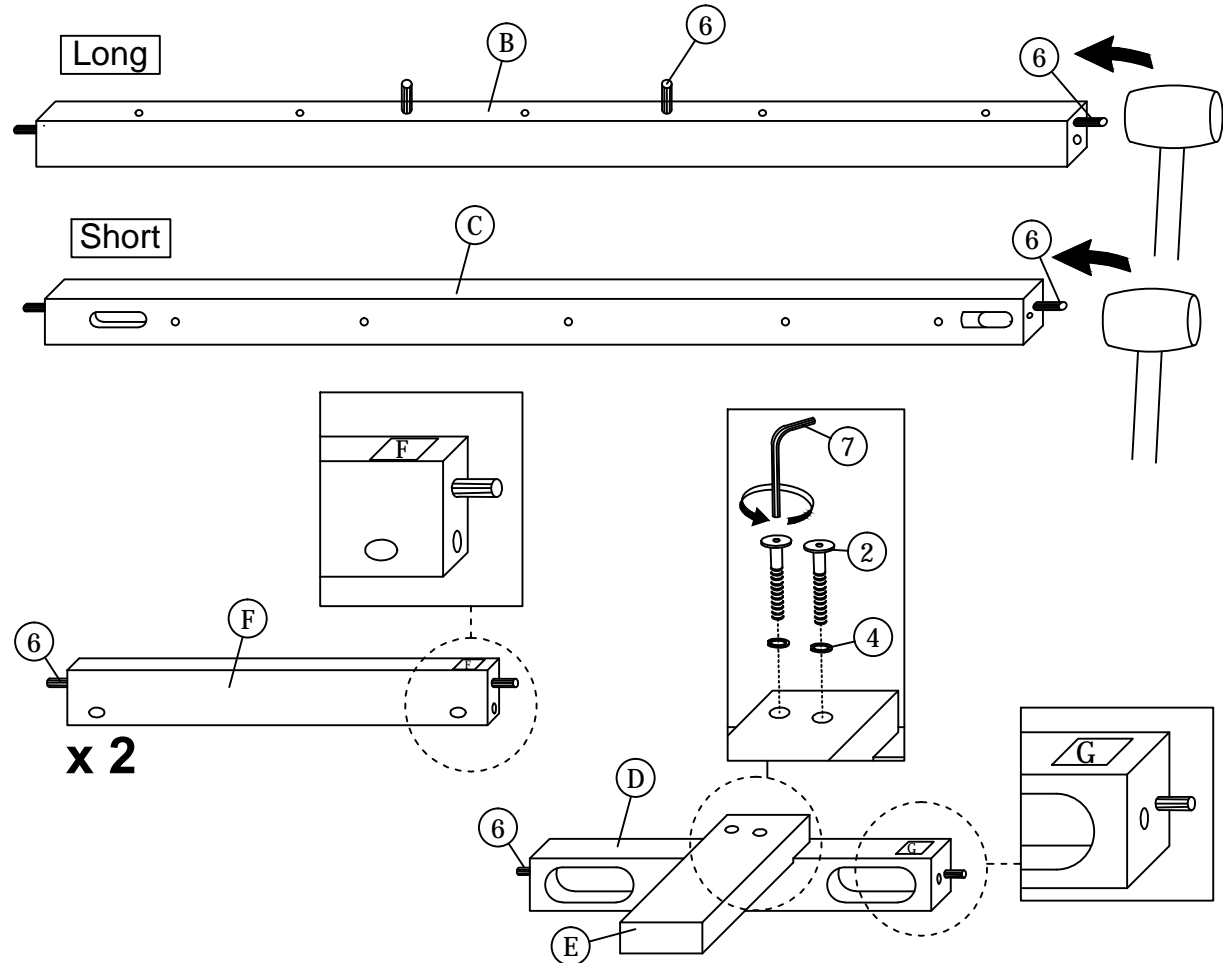
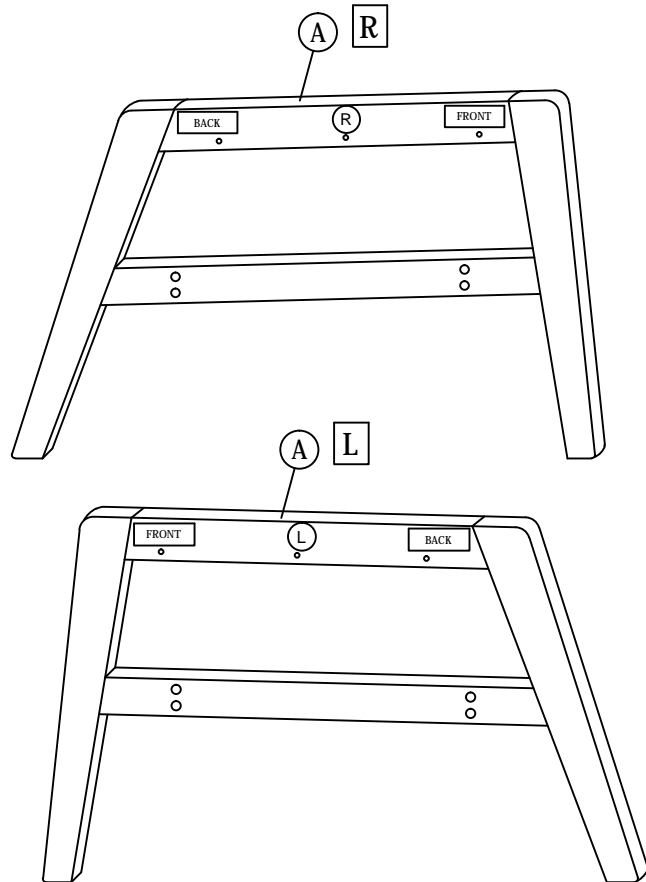

ASSEMBLY INSTRUCTIONS

STEP 2

STEP 2.1

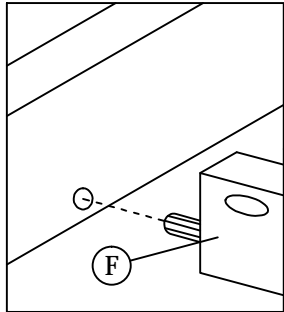

STEP 2.2

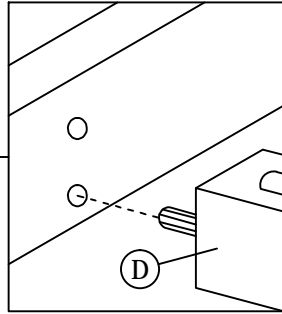

STEP 2.3

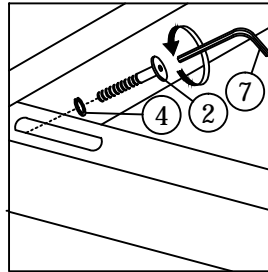

Don't screw tied

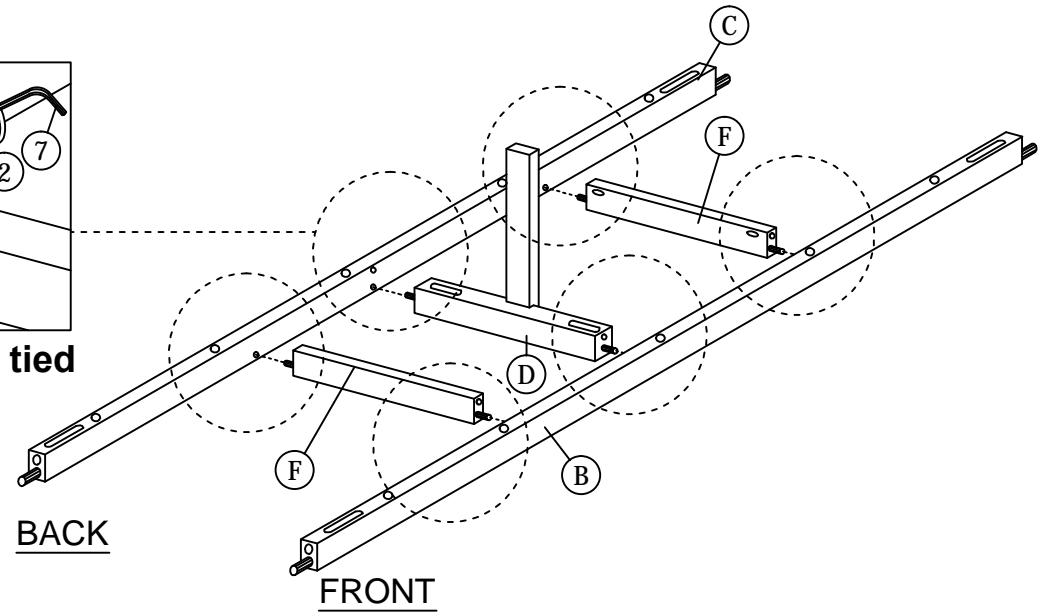

STEP 3

STEP 3.1

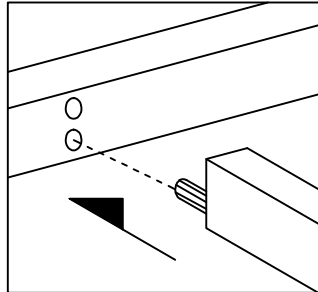

STEP 3.2

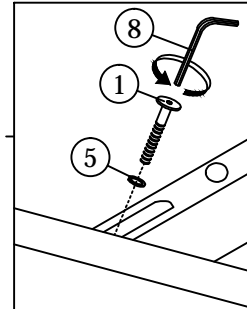

Don't screw tied

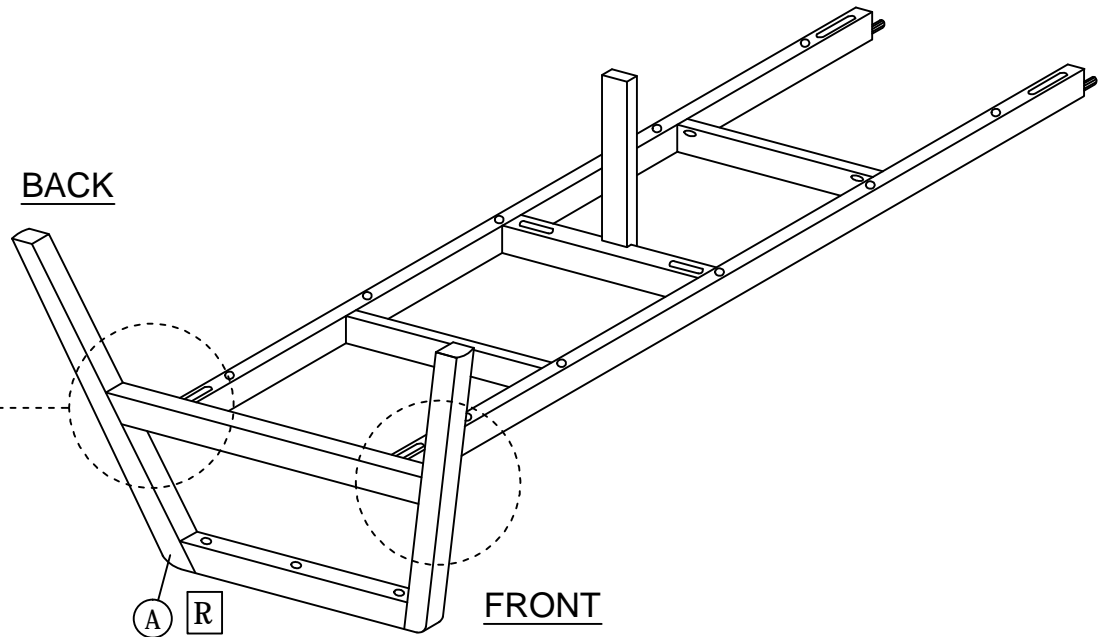

ASSEMBLY INSTRUCTIONS

STEP 4

STEP 4.1

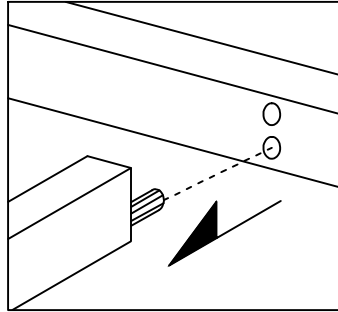

STEP 4.2

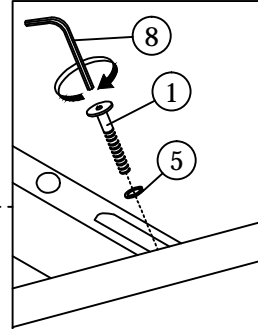

Don't screw tied

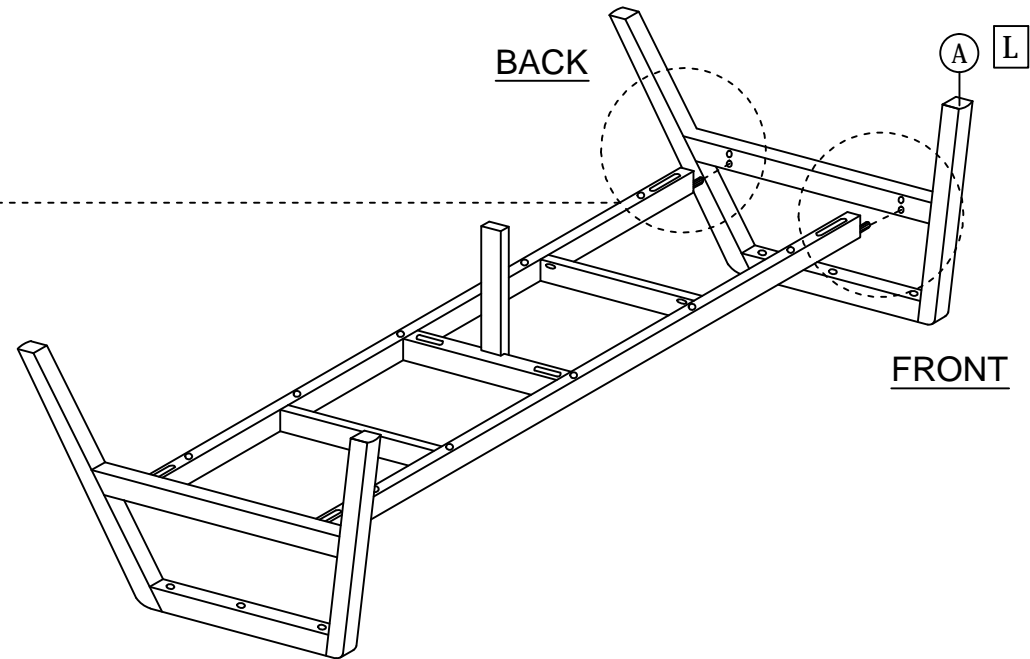

STEP 5

****Finish step 5, Please screw tied the step 2 , 3 & 4 bolt.**

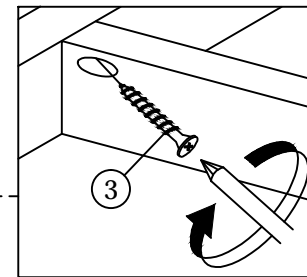
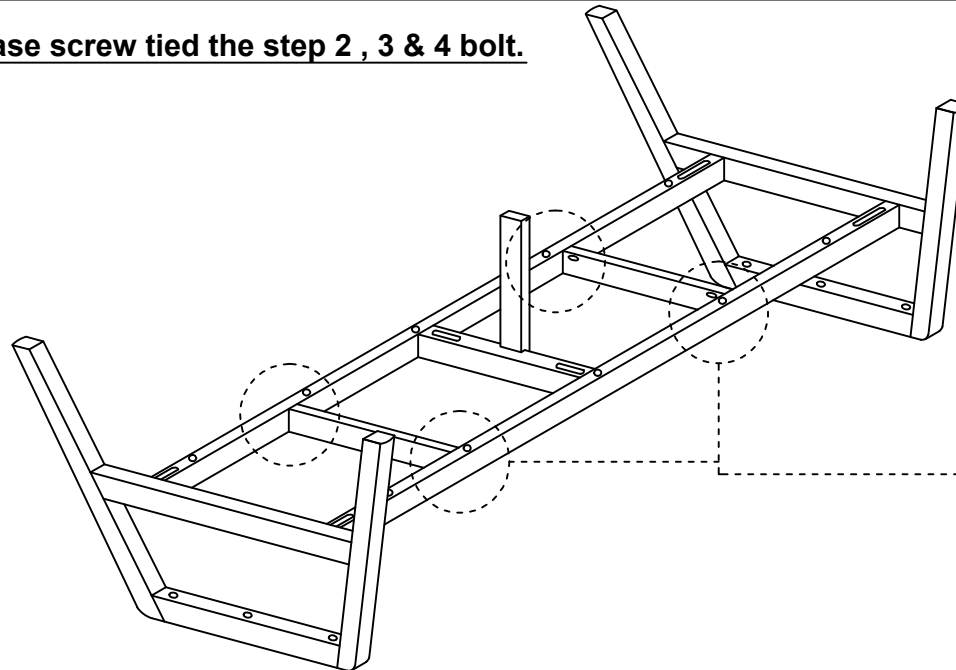

ASSEMBLY INSTRUCTIONS

STEP 6

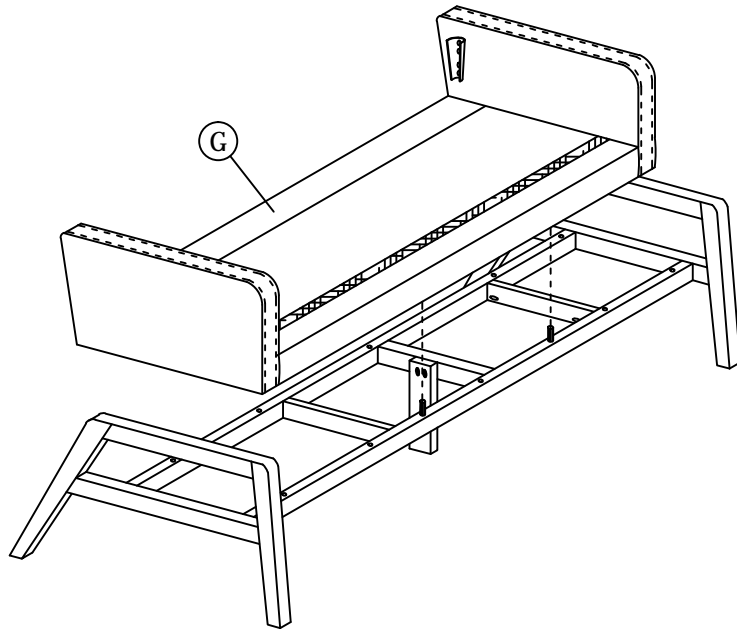

STEP 7

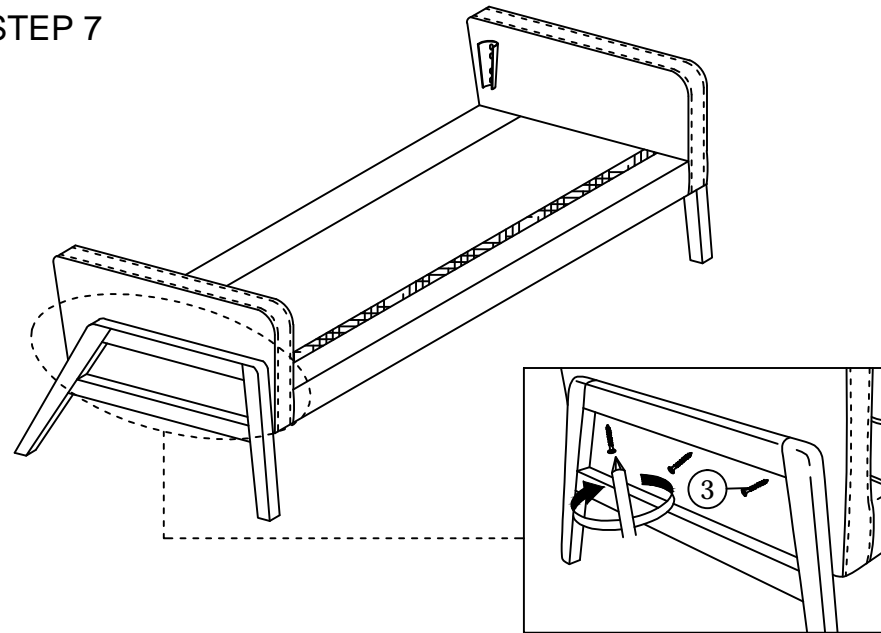

STEP 8

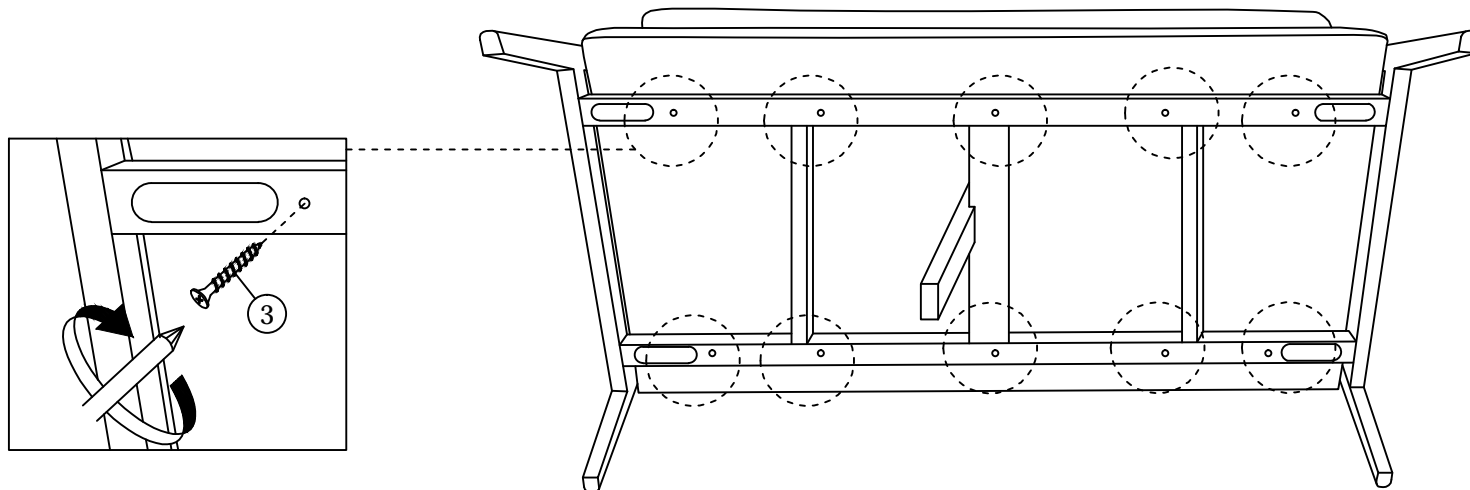

ASSEMBLY INSTRUCTIONS

STEP 9

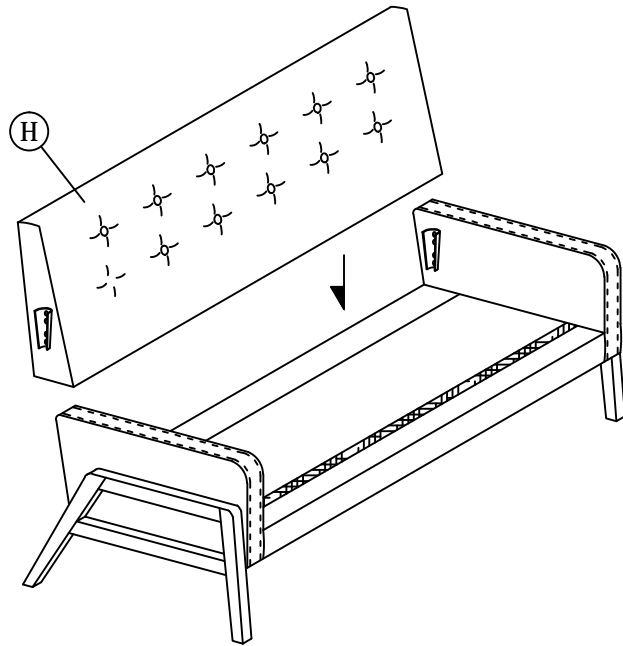

STEP 10

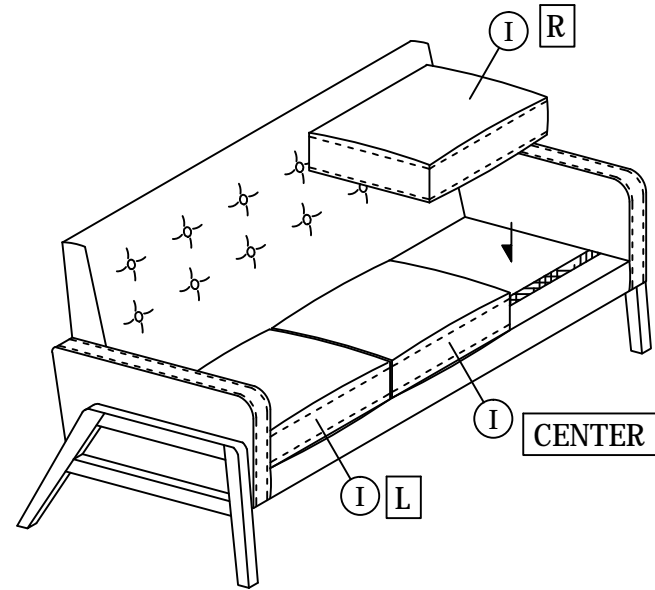

STEP 11

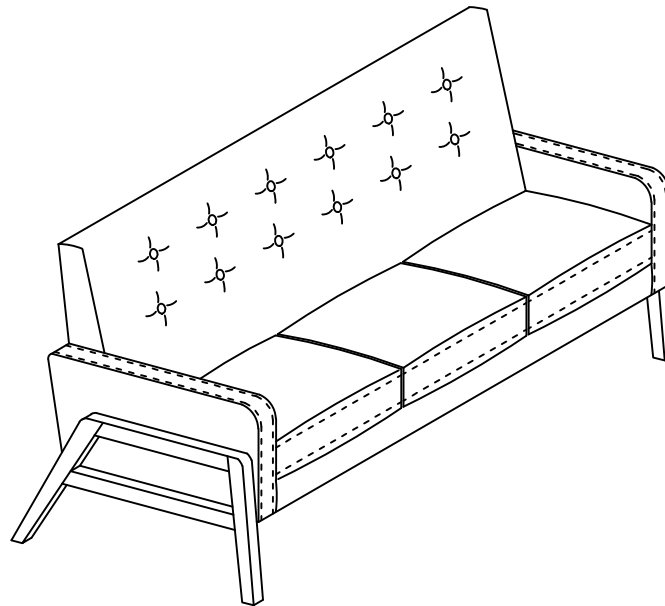

ASSEMBLY INSTRUCTIONS

Read this instruction carefully. See hardware and furniture part list for guidance. Be sure all parts are complete, before you assemble. Place all wooden furniture parts on a clean and flat soft surface to prevent from being scratched. Follow the figure to start assembling.

CAUTIONS : 1. Do not FULLY - TIGHTEN the nut or nut bolt until all nut or bolt is ready assembled.
 2. Do not OVER - TIGHTEN the nut or bolt to avoid causing damages to the thread.
 3. Keep all hardware parts out of reach of children.

PART LIST		
ITEM	DESCRIPTION	QTY
A	CUSHION SEAT	1pc
B	FRONT STRETCHER	1pc
C	BACK STRETCHER	1pc
D	LEG	2pcs

HARDWARE LIST		
ITEM	DESCRIPTION	QTY
1	JCBB Bolt M8 x 50mm	4pcs
2	Wood Screw M4 x 38mm	10pcs
3	M8 Spring Washer	4pcs
4	Wood Dowel M10 x 30mm	5pcs
5	M5 Allen Key (Ball Shape)	1pc

NOTE : THE LIST AND QUANTITY SHOWN ARE FOR 1 UNIT ASSEMBLY.

Tool needed : Screwdriver & Hammer (not provided).

STEP 1

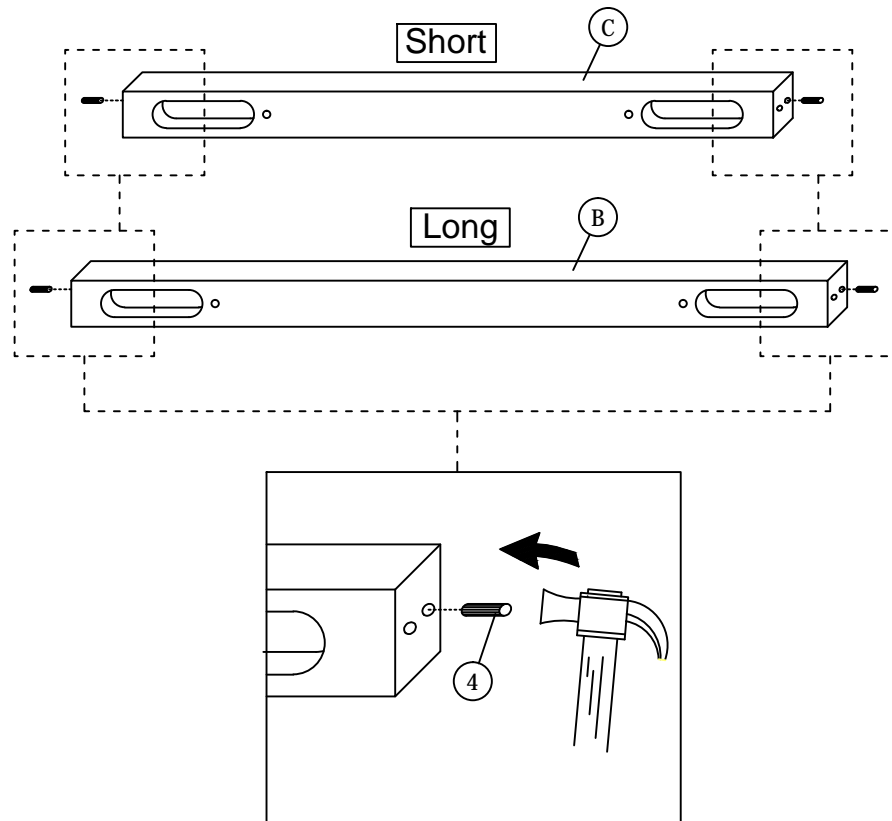

STEP 2

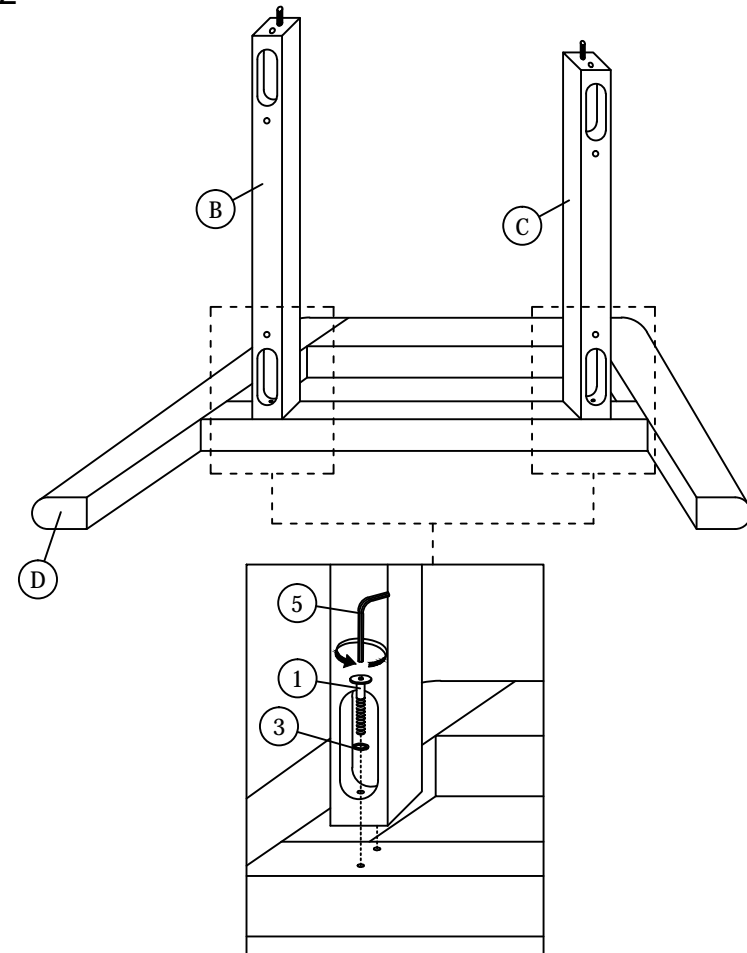

ASSEMBLY INSTRUCTIONS

STEP 3

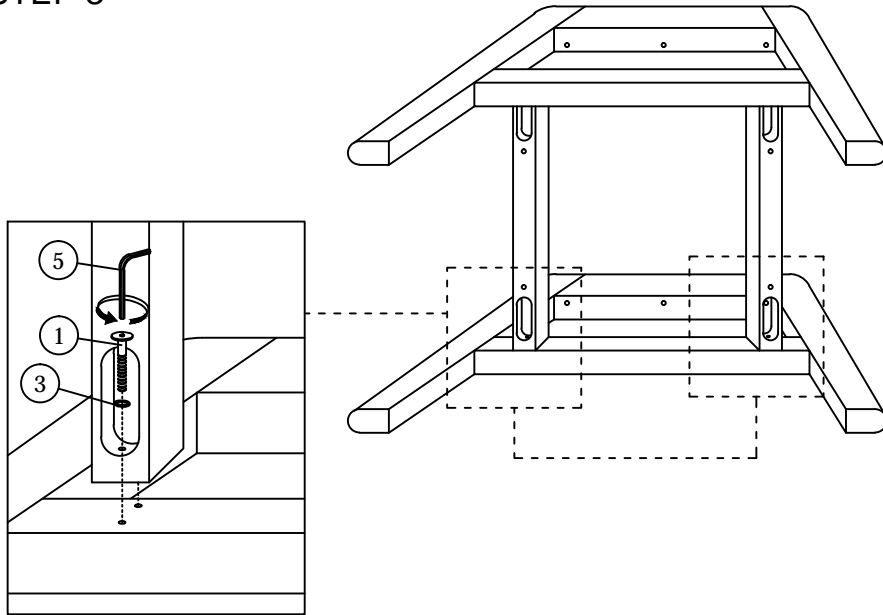

STEP 4

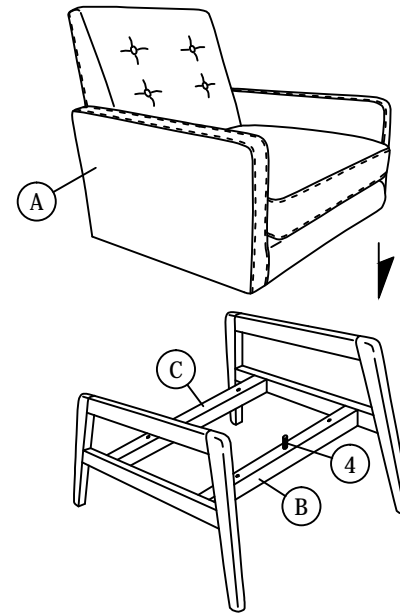

STEP 5

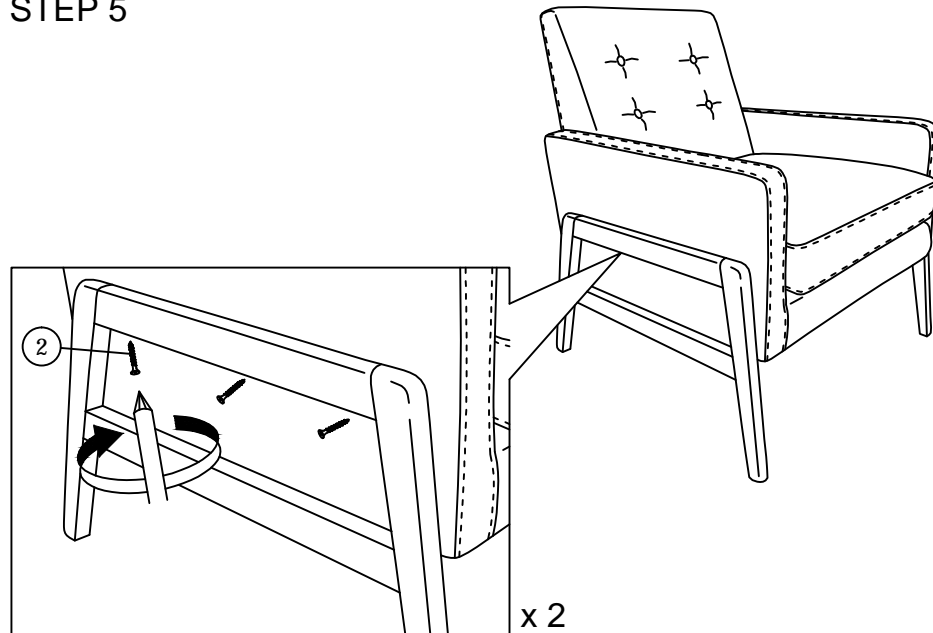

STEP 6

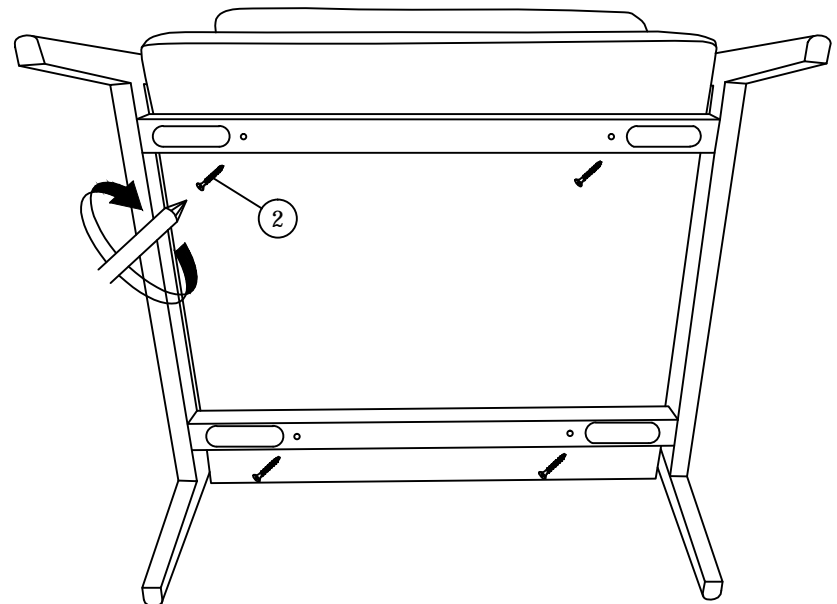

ASSEMBLY INSTRUCTIONS

STEP 7

