

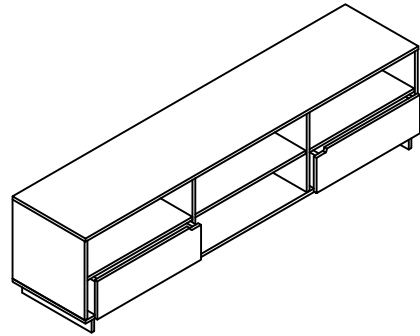













# Assembly Instructions

Part List		QTY	Part List		QTY
1	Top Panel	1	8	Back Panel	1
2	Right Side Panel	1	9	Drawer Front Panel	2
3	Left Side Panel	1	10	Drawer Back Panel	2
4	Middle Center Panel	1	11	Drawer Side Panel	4
5	Middle Panel Support	2	12	Drawer Bottom Panel	2
6	Middle Panel Support Center	1	13	Drawer Support Bottom Panel	2
7	Bottom Panel	1	14	Middle Support Leg	1
			15	Side Legs	2
			16	Middle Center Panel	1



Hardware		QTY
A	Allen Key M4 	1
B	Wood Dowel 	32
C	Mini Fix Bolt 	24
D	Mini Fix Housing 	24
E	Mini Fix Cap 	24
F	CSK Screw M3.5x16mm 	24
G	CSK Screw M4x32mm 	4
H	CSK Screw M4x50mm 	16
I	JCBC W Screw M6x40 	8
J	Shelf Support Metal 	4
K	350mm Drawer Slide 	2
L	Power Nail 5/8 	60
M	White Nail Leg 	6

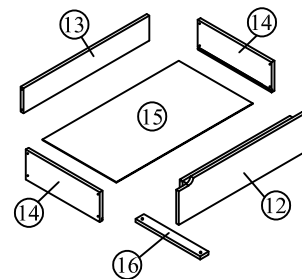
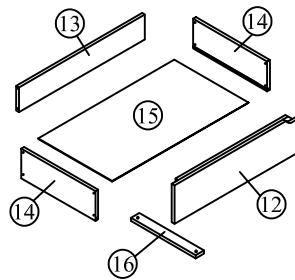
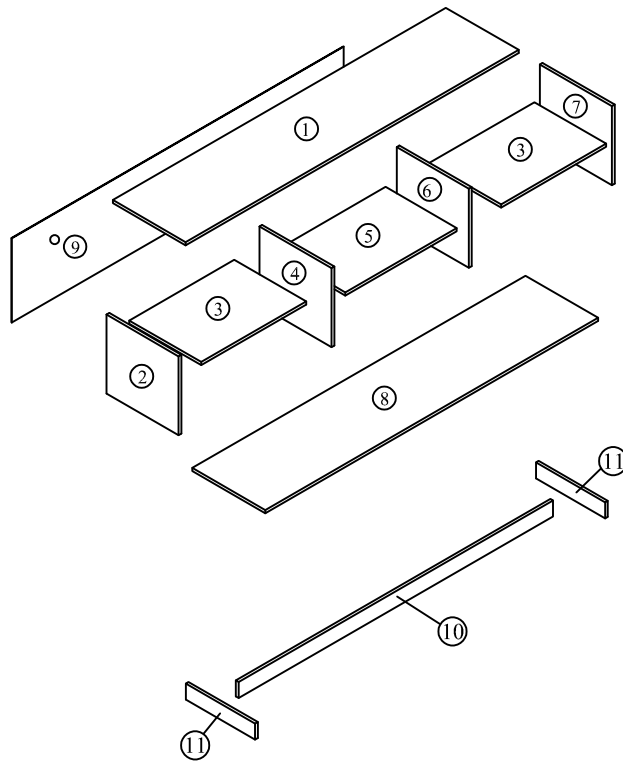

# Step 1

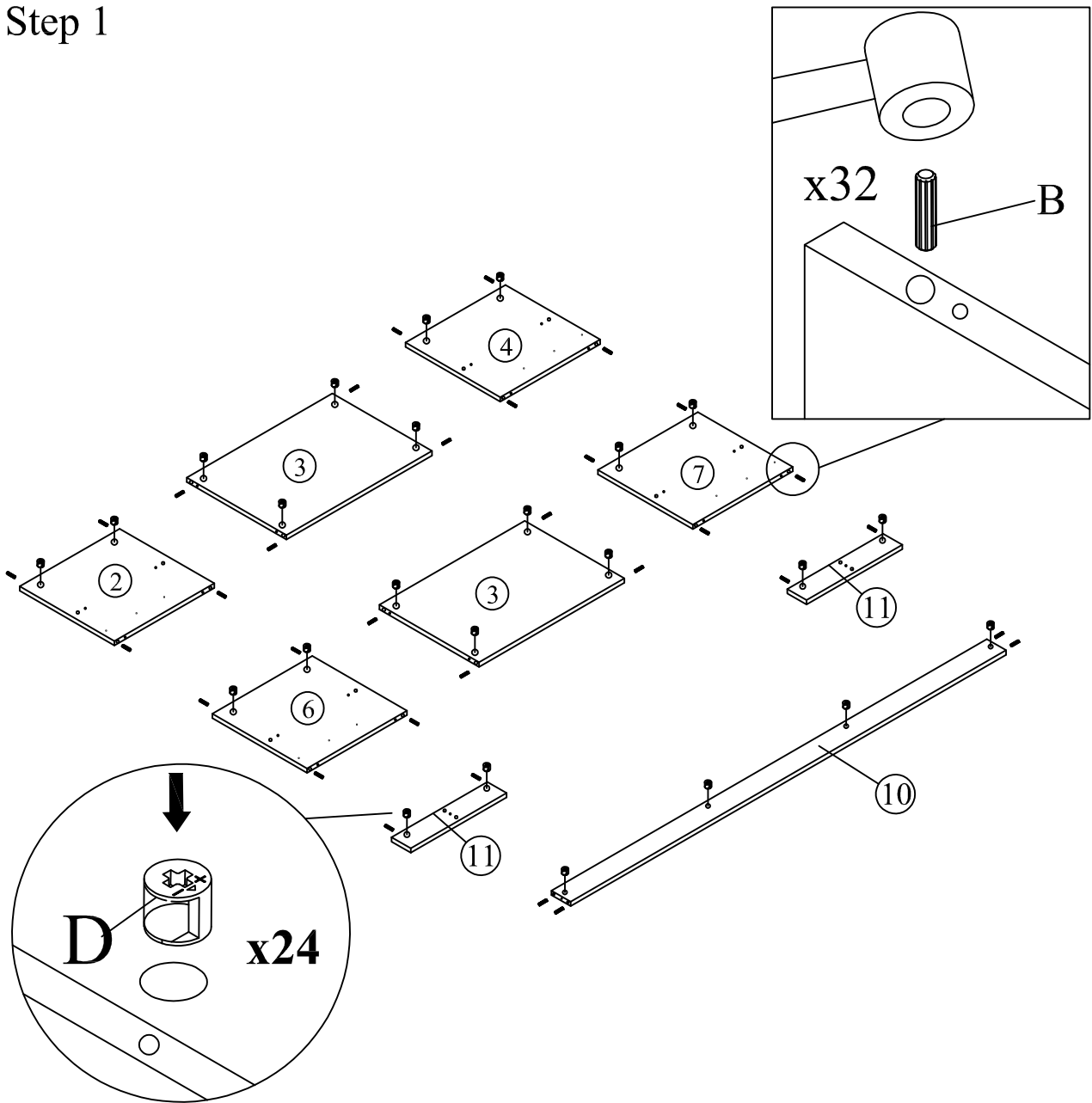

# Step 2

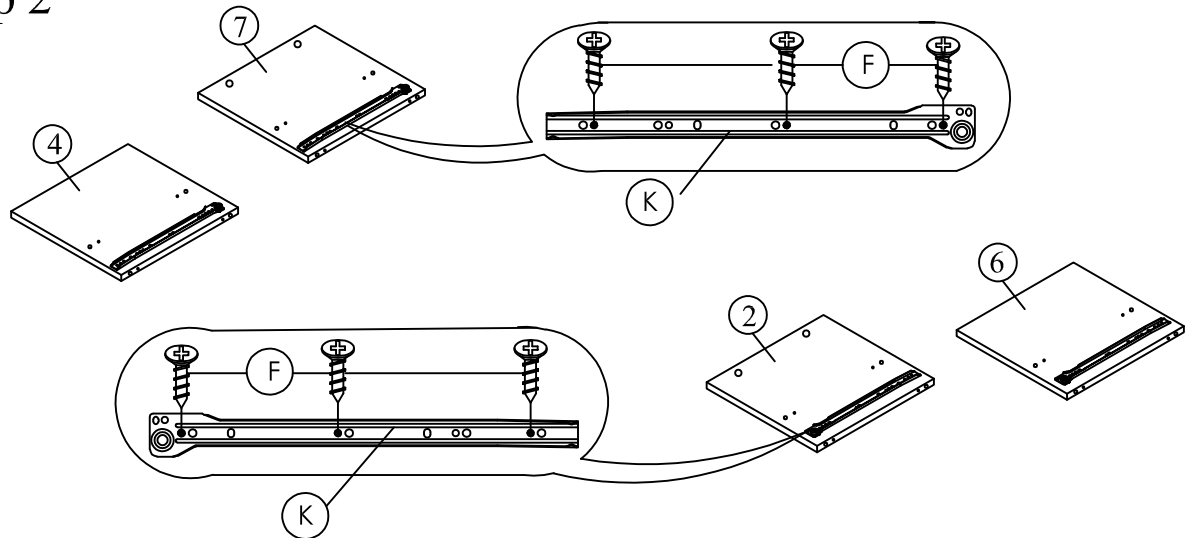

### Step 3

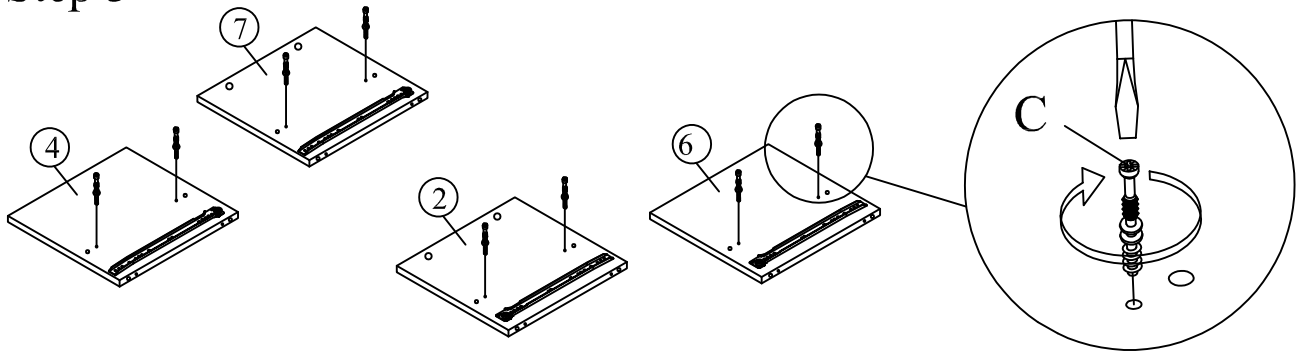

### Step 4

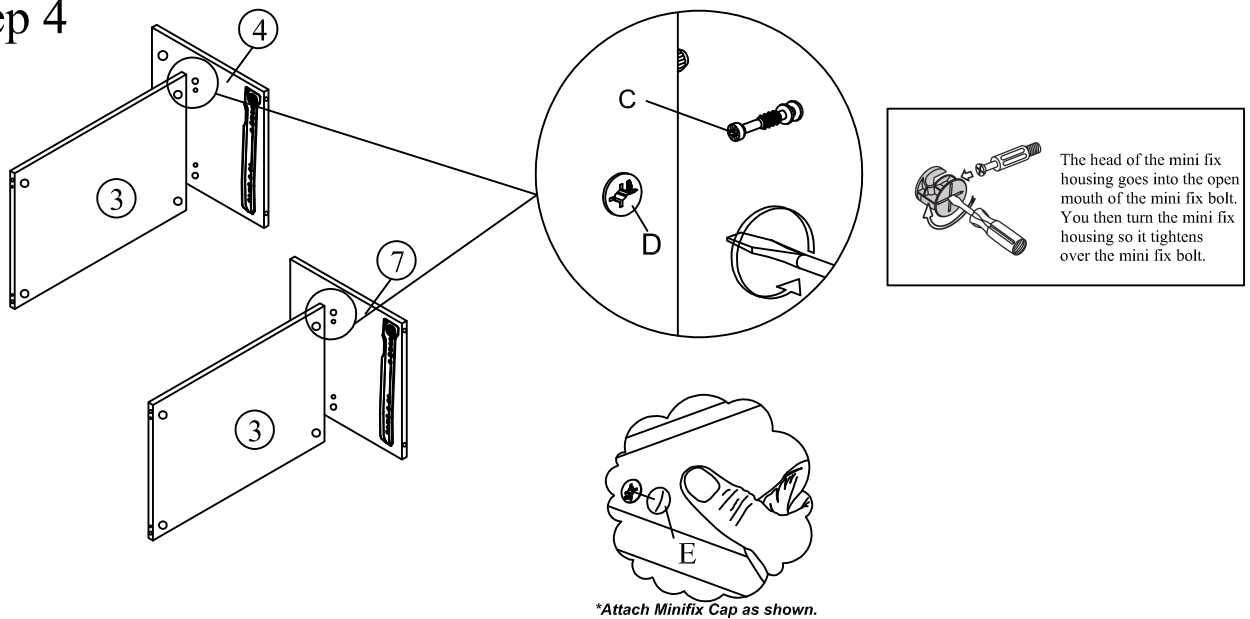

### Step 5

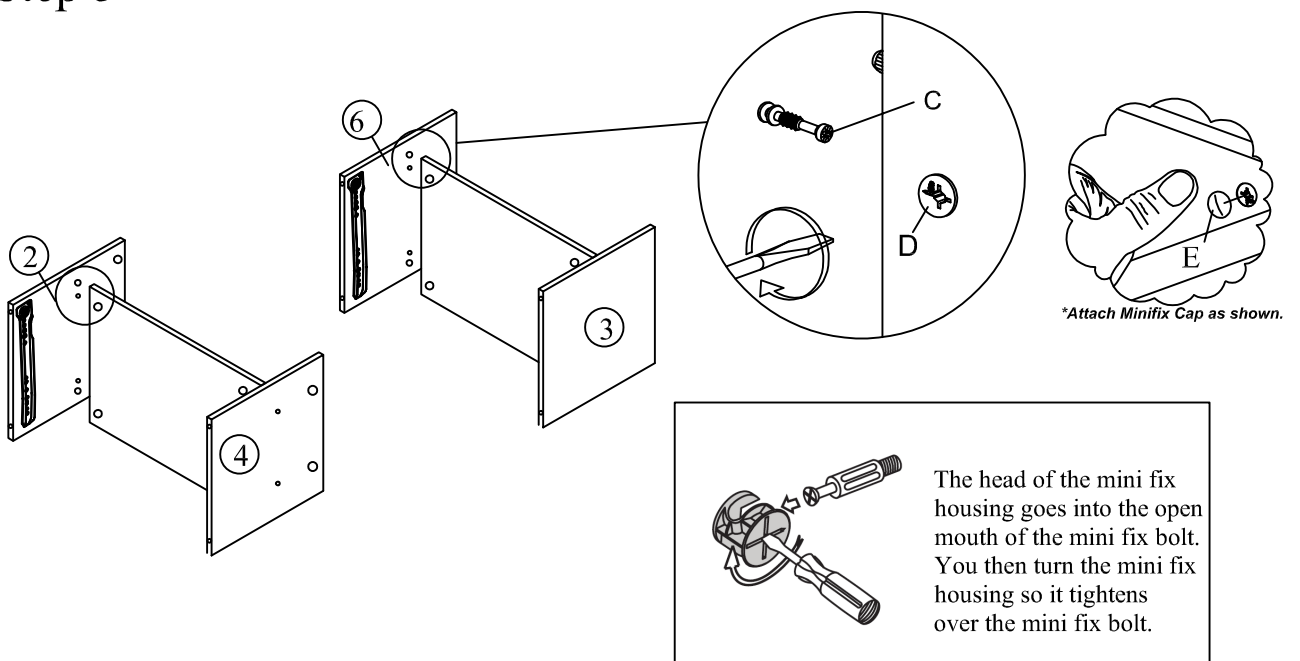

## Step 6

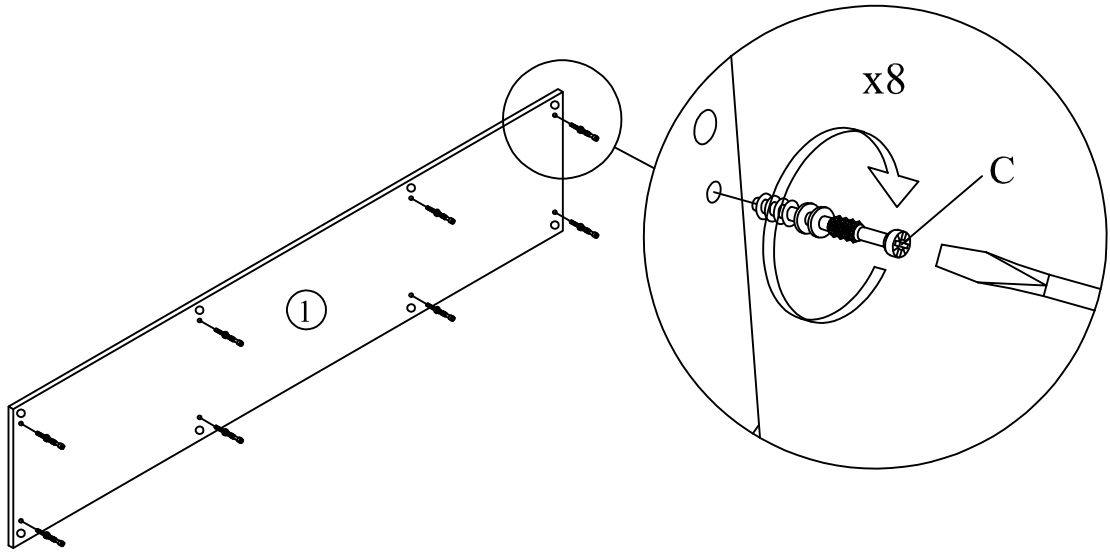

## Step 7

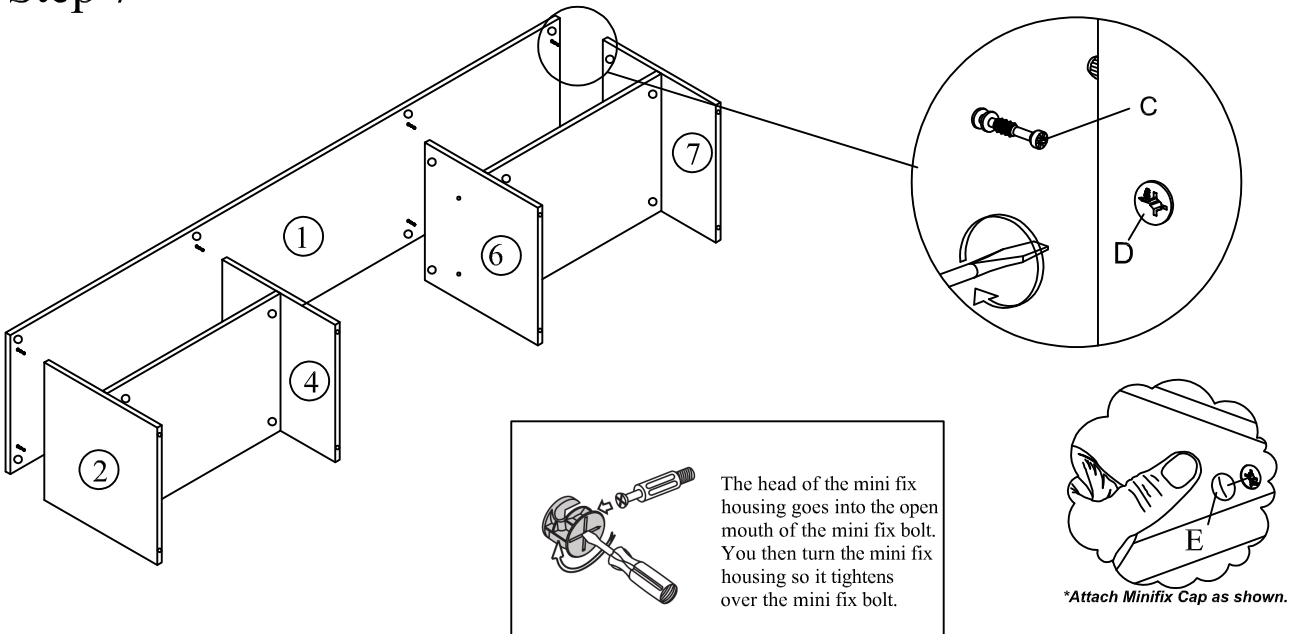

## Step 8

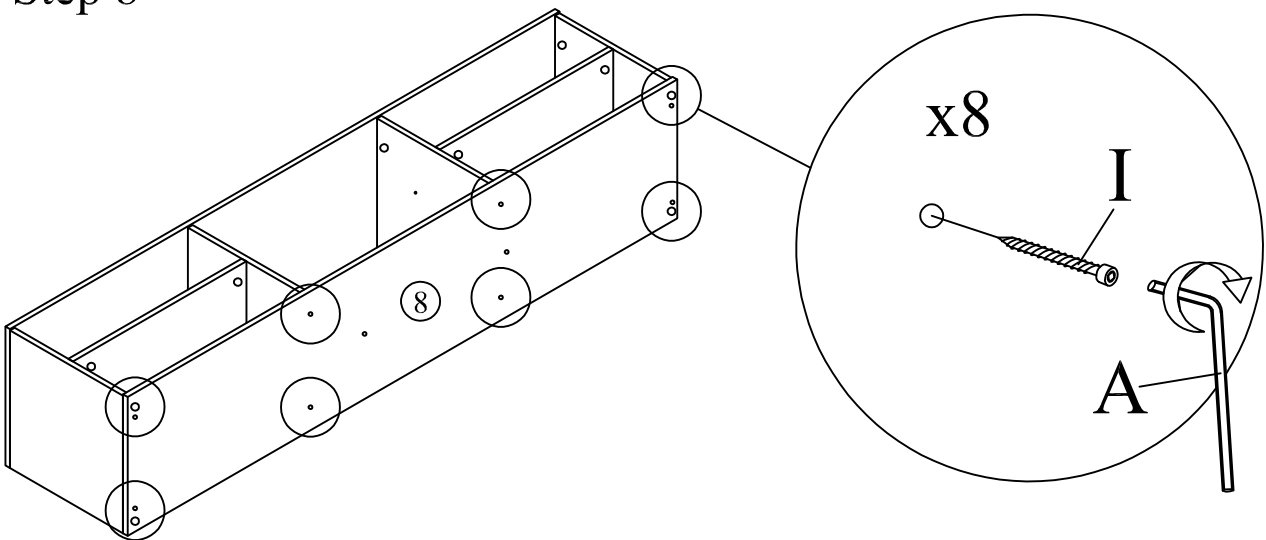

## Step 9

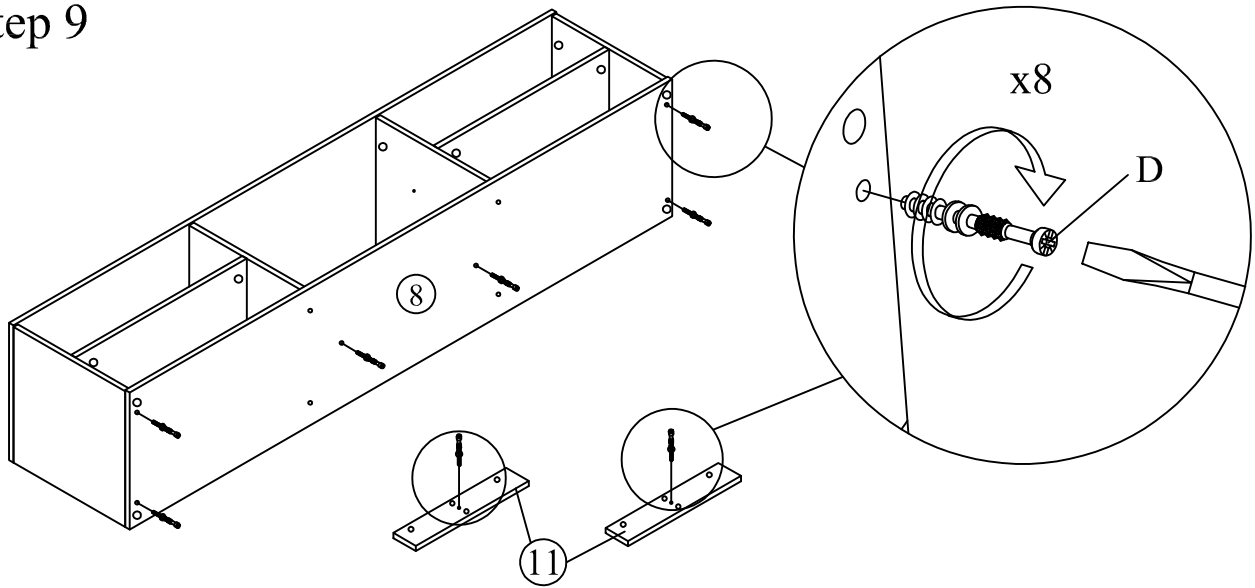

## Step 10

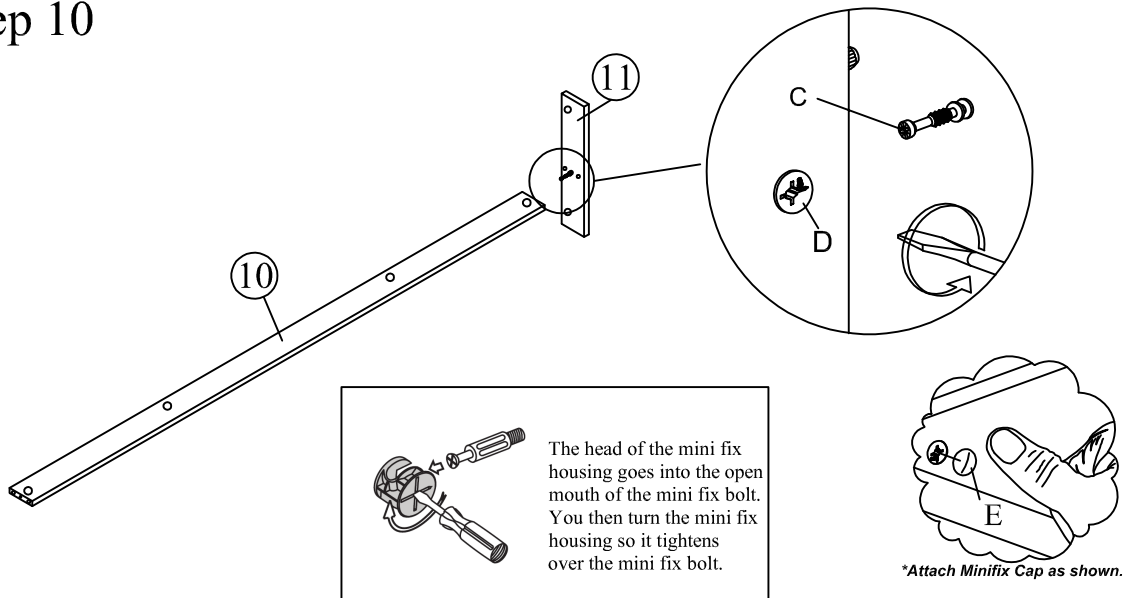

## Step 11

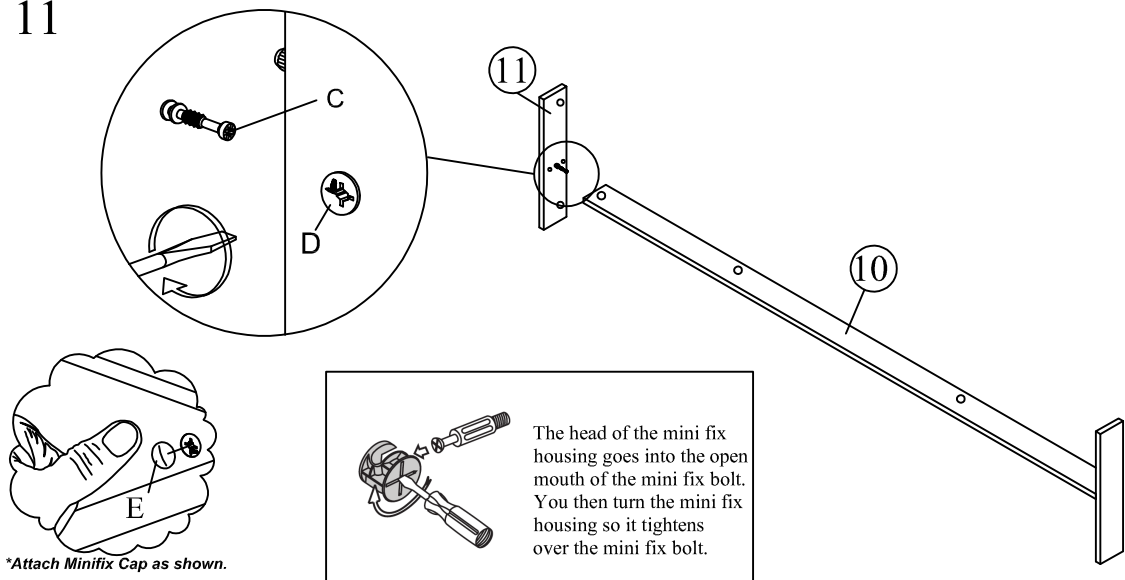

## Step 12

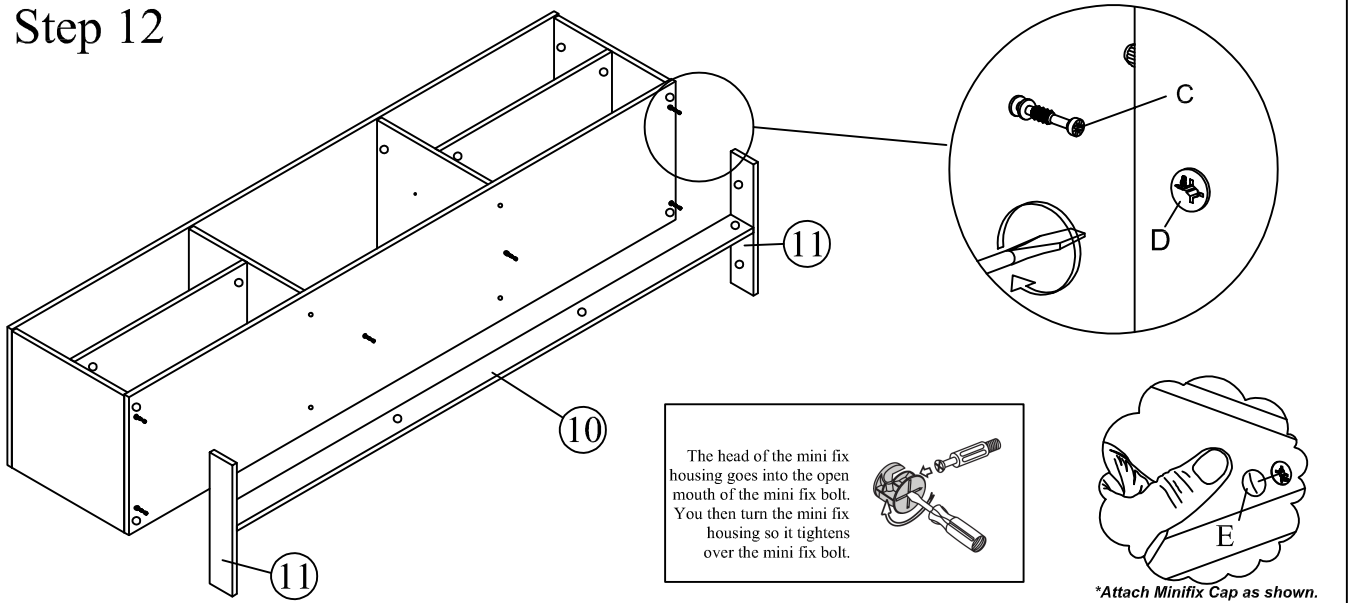

## Step 13

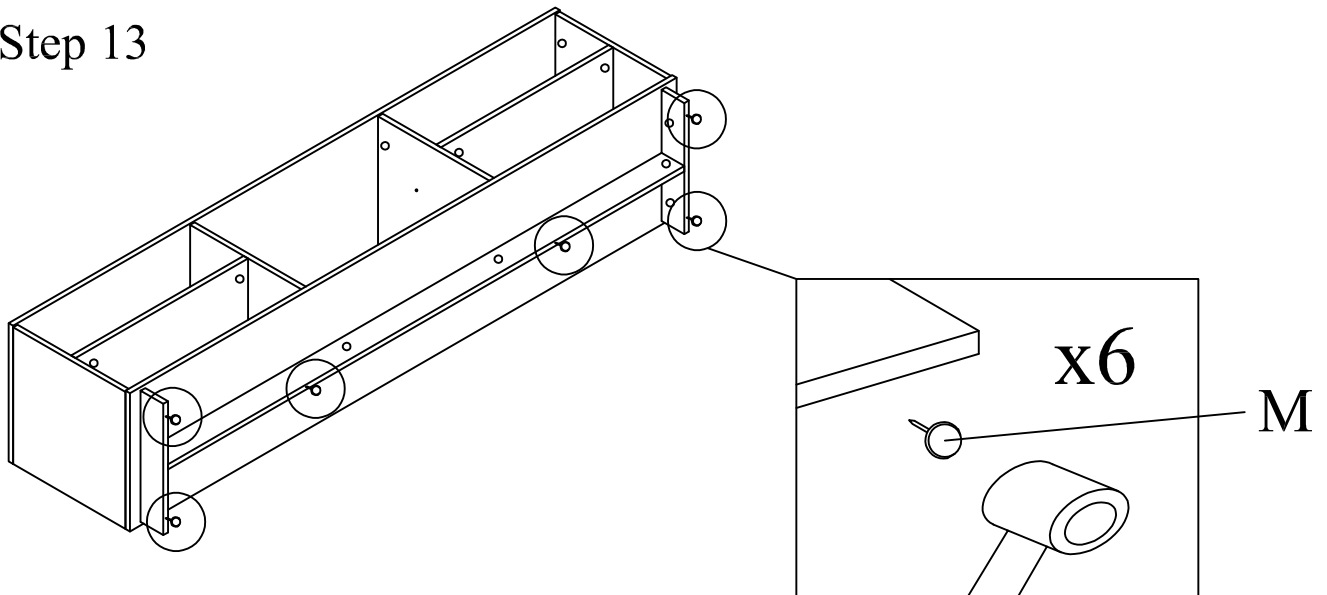

## Step 14

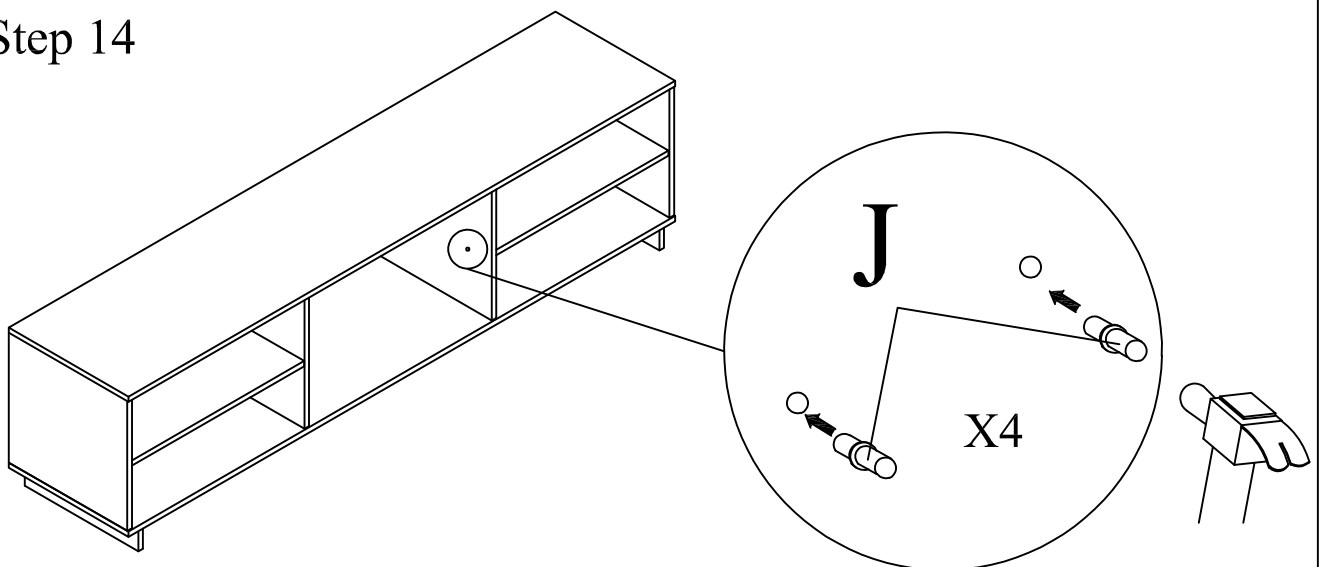

Step 15

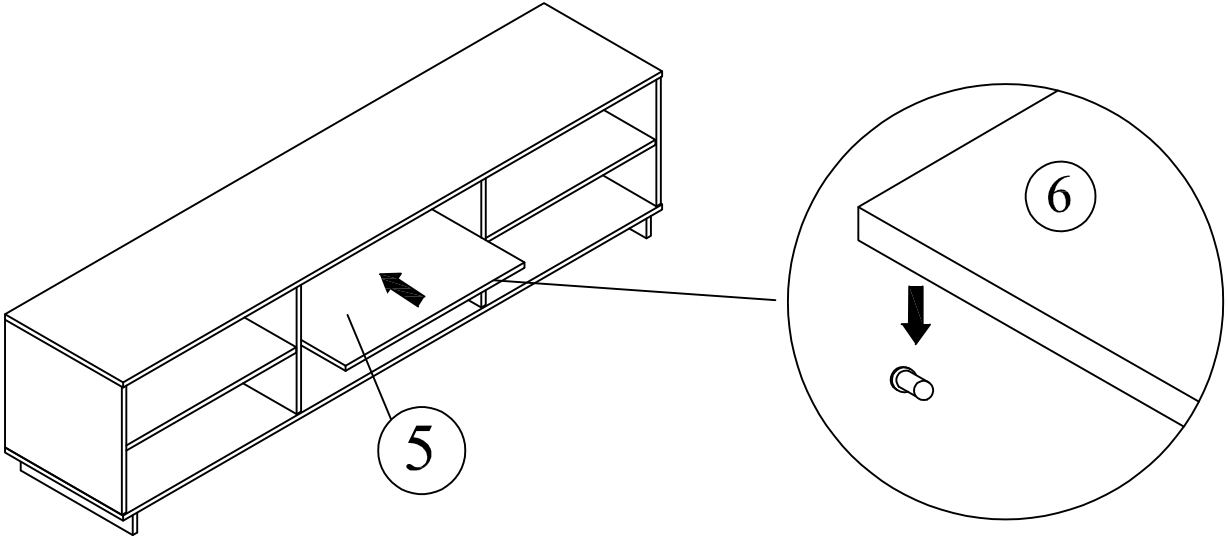

Step 16

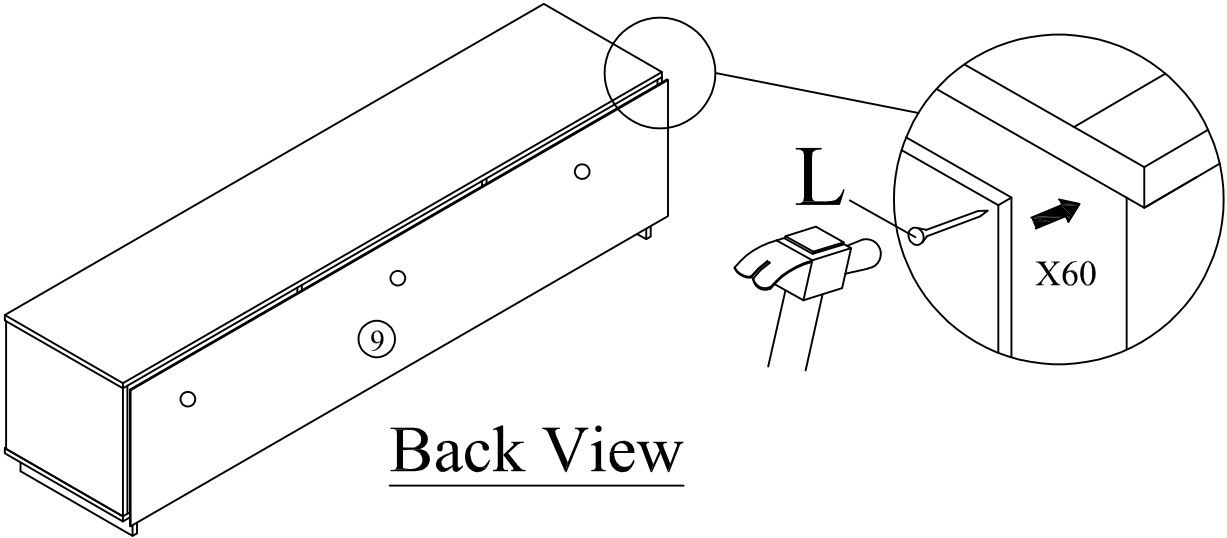

# Step 17

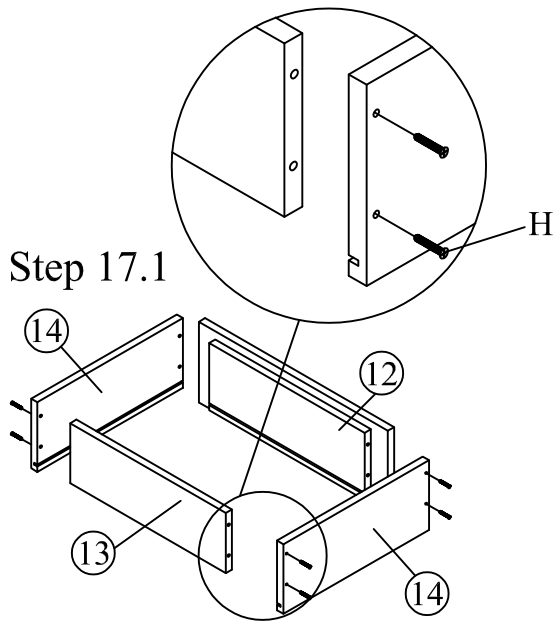

# Step 17.2

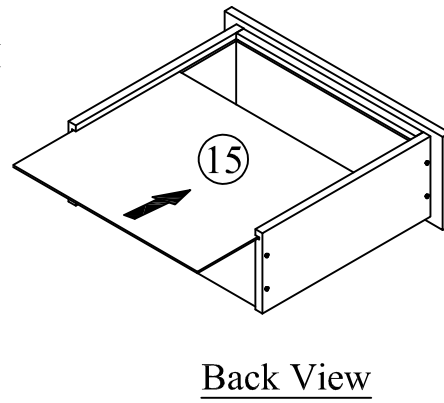

# Step 17.3

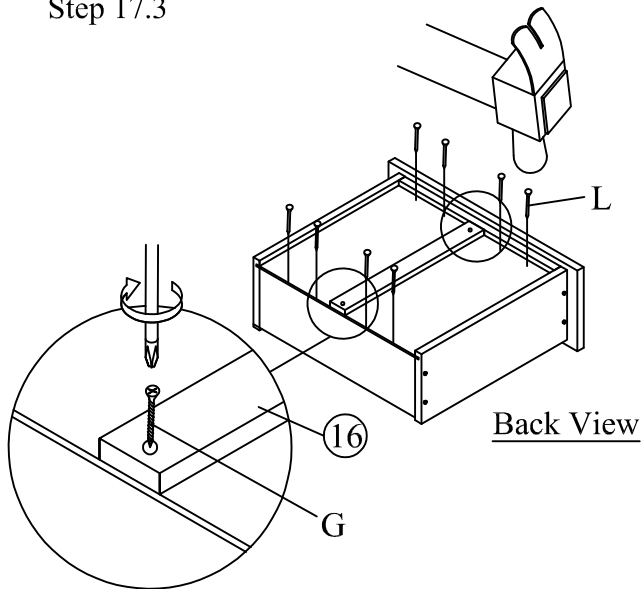

# Step 17.4

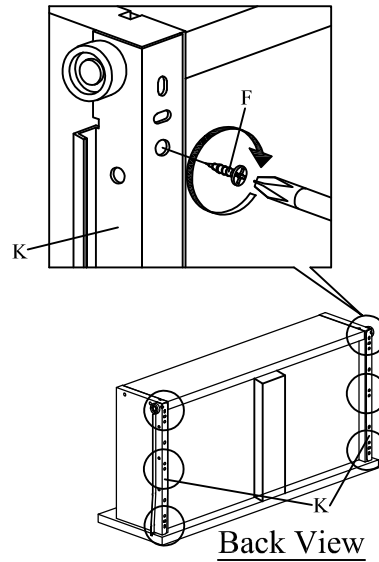

# Step 18

