

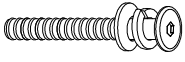

ASSEMBLY INSTRUCTIONS

IMPORTANT NOTE :

- * PLACE ALL WOODEN PARTS ON A CLEAN AND SMOOTH SURFACE SUCH AS A RUG OR CARPET TO AVOID THE PARTS FROM BEING SCRATCHED.
- * BEFORE YOU BEGIN, KINDLY FOLLOW THE ASSEMBLY INSTRUCTIONS STEP BY STEP.

HARDWARE LIST		
A	JCBC M6 x 70mm + S/W M6 + F/W M6 x 13mm 	8PCS
B	ALLEN KEY M4 	1PC
C	PH C/B SCREW #8 x 32mm 	4PCS

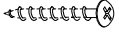
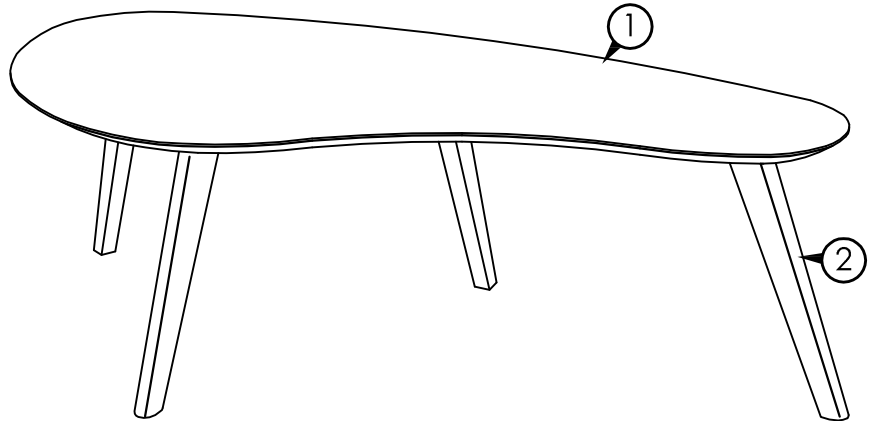

PART LIST		
1	TABLE TOP	1PC
2	TABLE LEG	4PCS

COMPLETED TABLE ASSEMBLY.

STEP 1

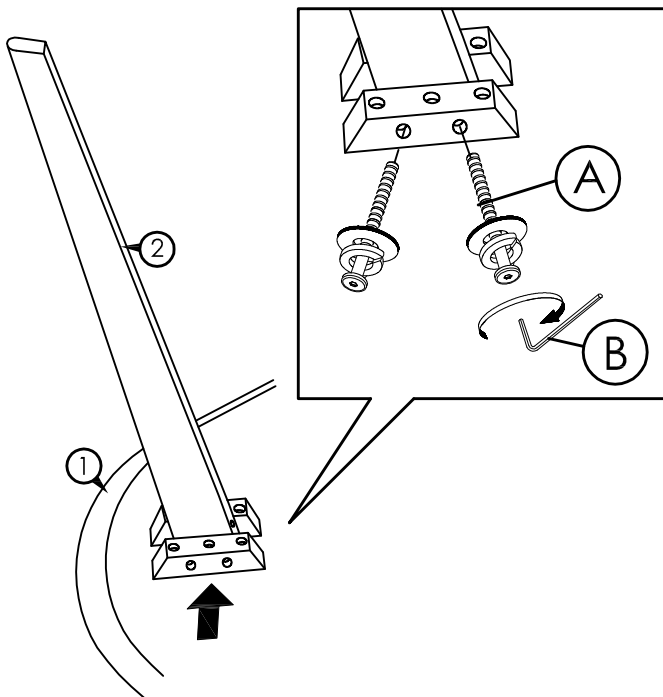

STEP 2

