









Assembly Instructions

Part List		QTY
1	Top Panel	1
2	Left Side Panel	1
3	Big Middle Panel	1
4	Small Middle Panel	1
5	Bottom Panel	1
6	Right Side Panel	1
7	Legs	4

Hardware		QTY
A	Allen Key M4 	1
B	Dowel 	12
C	JCBC W Screw M6x40 	6
D	Mini Fix Bolt 	6
E	Mini Fix Housing 	6
F	Mini Fix Cap 	6
G	CSK Screw M4x20mm 	16
H	Shell Support Metal 	4
I	MT81 Support Leg 	4

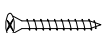

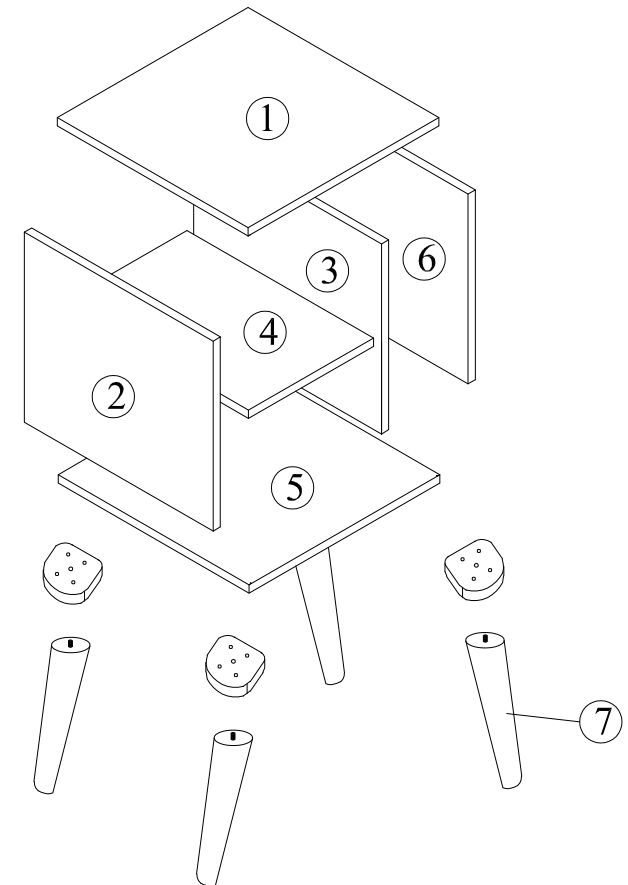
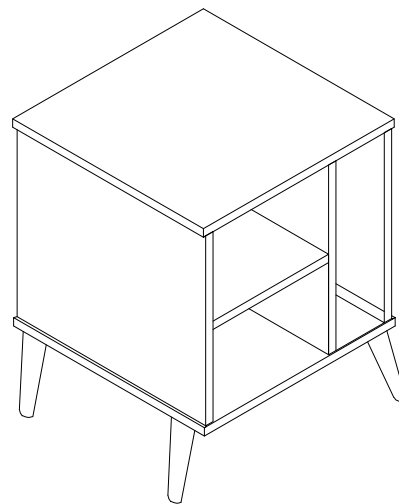
Step 1

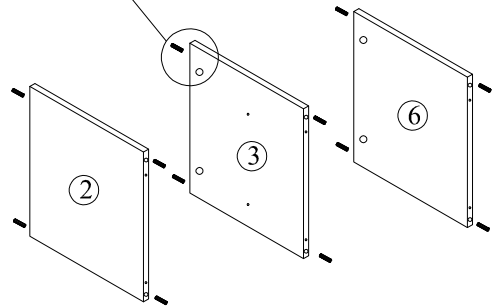
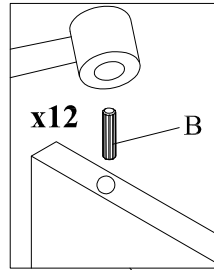

Step 2

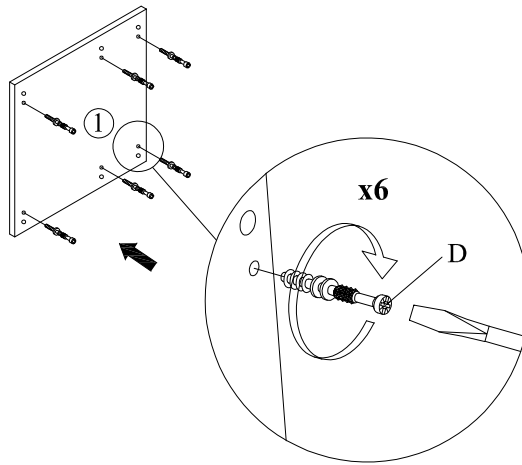

Step 3

This is how a mini fix works...
The head of the mini fix housing goes into the open mouth of the mini fix bolt. You then turn the mini fix housing so it tightens over the mini fix bolt.

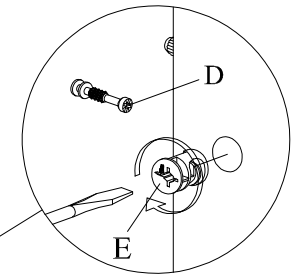

***Assemble right size panel (6), secure with Minifix as shown.**

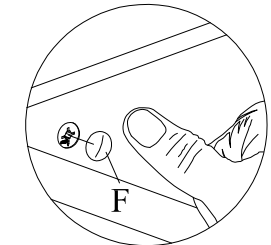
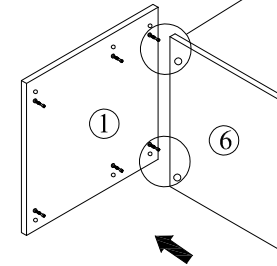

***Attach Minifix Cap as shown.**

Step 4

This is how a mini fix works...
The head of the mini fix housing goes into the open mouth of the mini fix bolt. You then turn the mini fix housing so it tightens over the mini fix bolt.

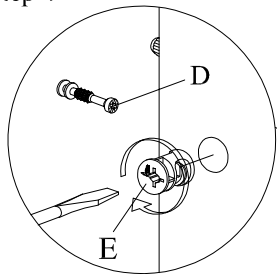

***Assemble right size panel (3), secure with Minifix as shown.**

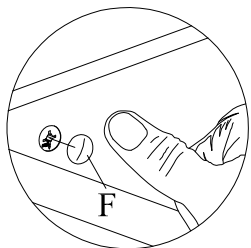
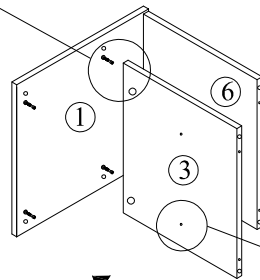

***Attach Minifix Cap as shown.**

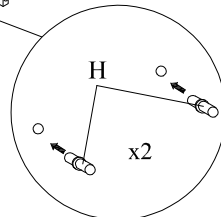

Step 5

This is how a mini fix works...
The head of the mini fix housing goes into the open mouth of the mini fix bolt. You then turn the mini fix housing so it tightens over the mini fix bolt.

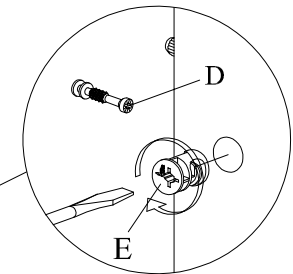

***Assemble right size panel (2), secure with Minifix as shown.**

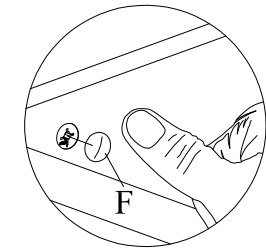
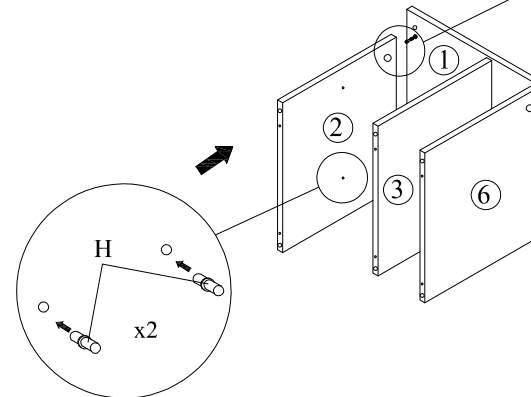

***Attach Minifix Cap as shown.**

Step 7

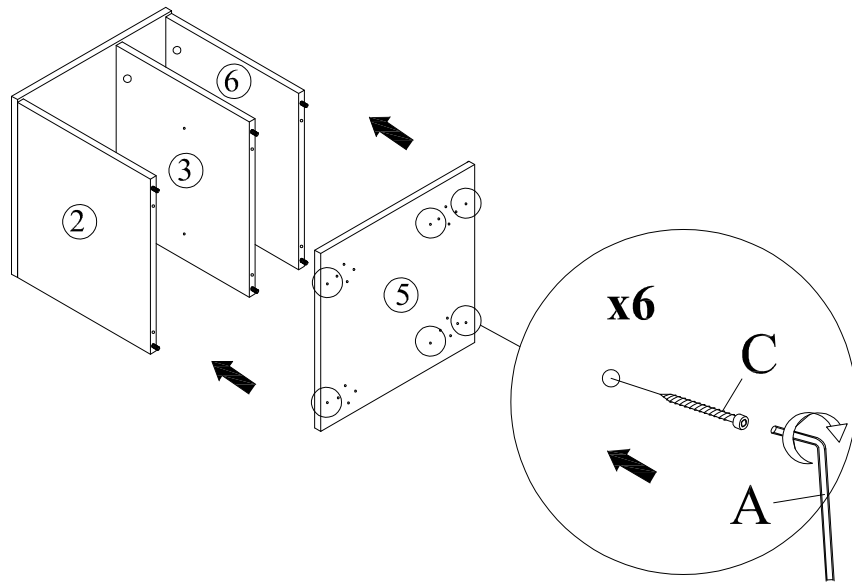

Step 8

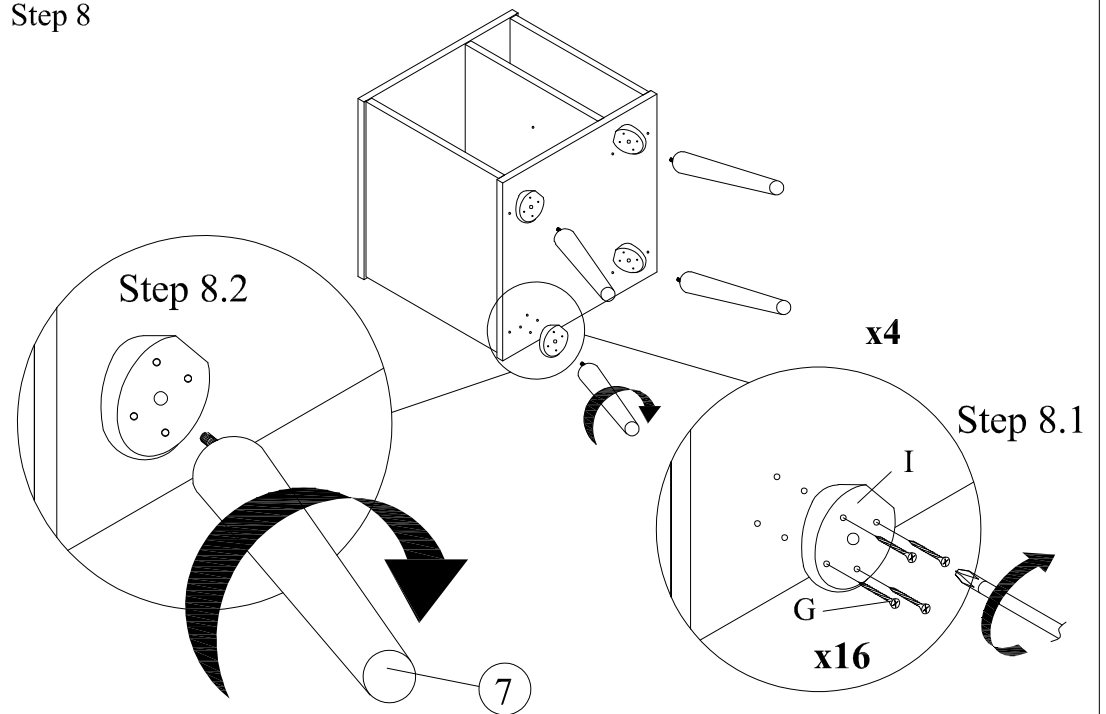

Step 9

