

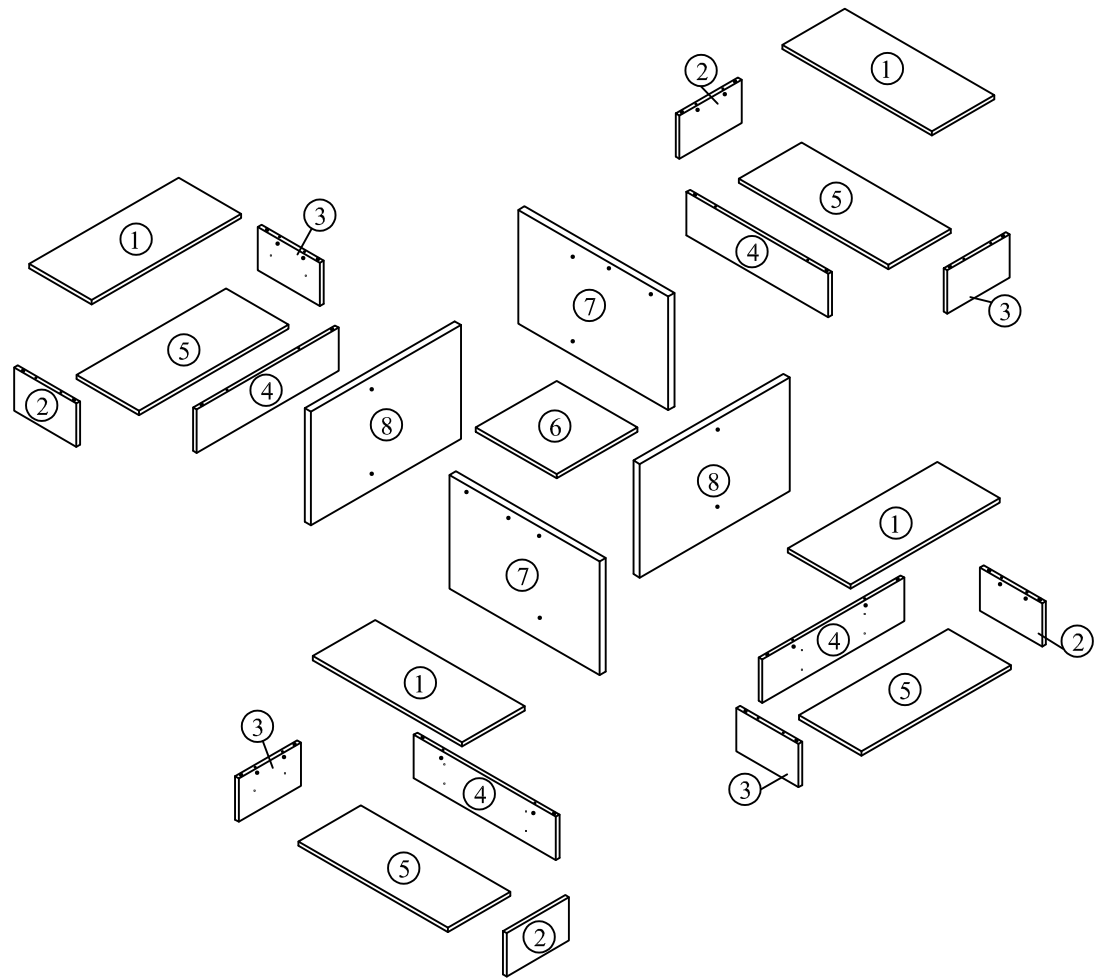

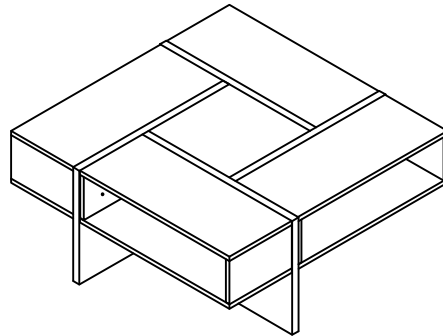







# Assembly Instructions

Part List		QTY
1	Top Panel	4
2	Side Panel	4
3	Side Panel (holes)	4
4	Back Panel	4
5	Bottom Panel	4
6	Top Middle Panel	1
7	Big Side Panel (holes)	2
8	Big Side Panel	2



Hardware		QTY
A	Allen Key M4 	1
B	Dowel 	68
C	JCBC W Screw M6x40 	24
D	JCBC W Screw M6x50 	12
E	Mini Fix Bolt 	32
F	Mini Fix Housing 	32
G	Mini Fix Cap 	32
H	CSK Screw M4x30mm 	24
I	CSK Screw Cap 	24
J	White Nail Leg 	8

Step 1

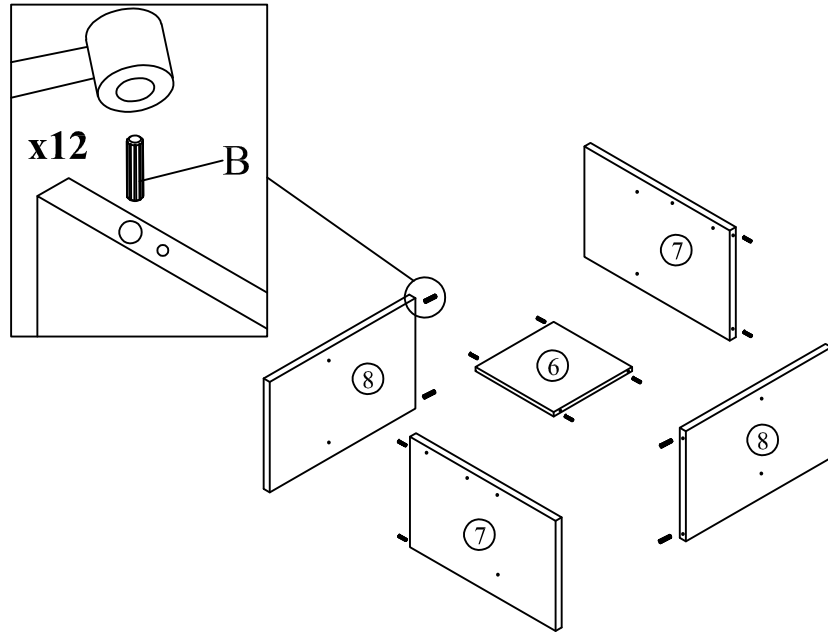

Step 2

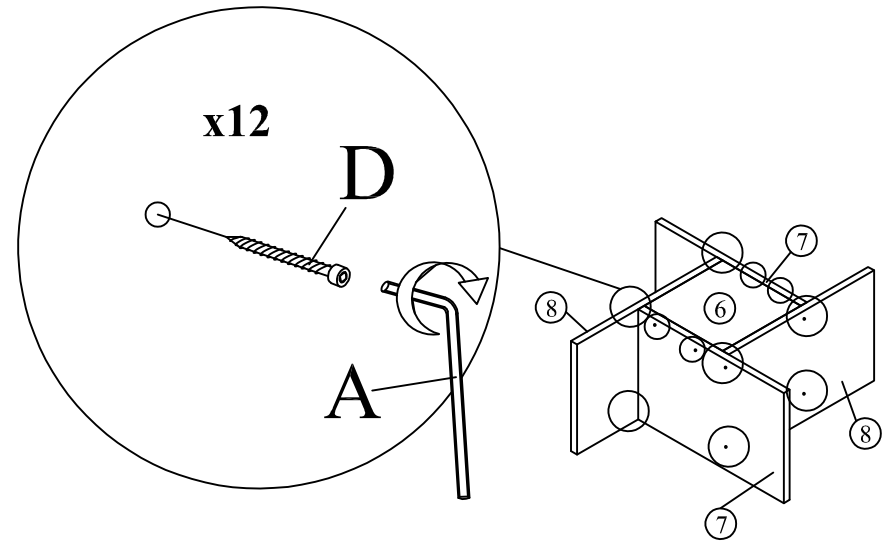

Step 3

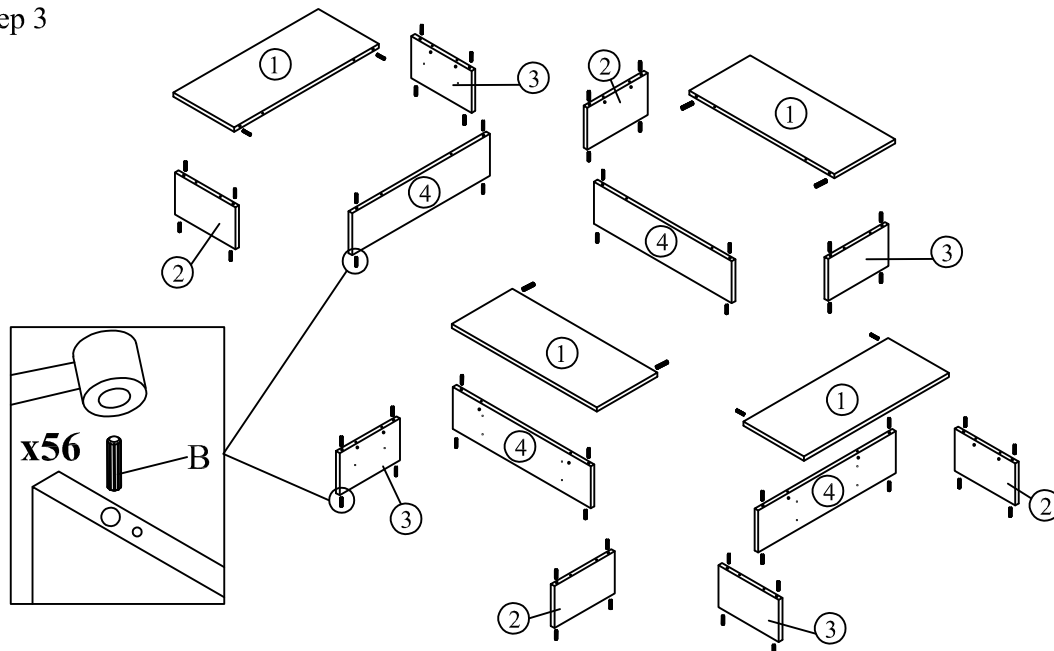

Step 4

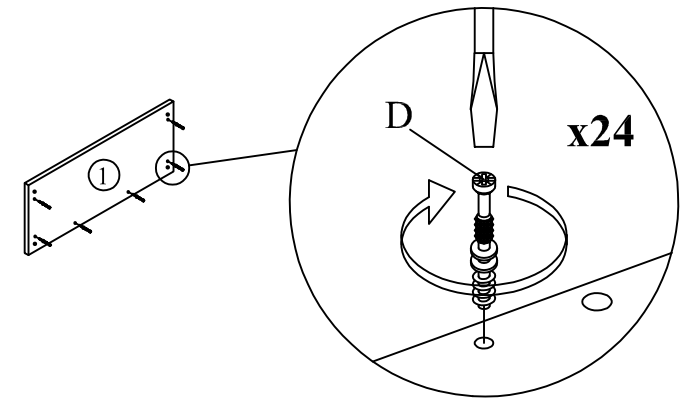

x4

Step 5

This is how a mini fix works...



The head of the mini fix housing goes into the open mouth of the mini fix bolt. You then turn the mini fix housing so it tightens over the mini fix bolt.

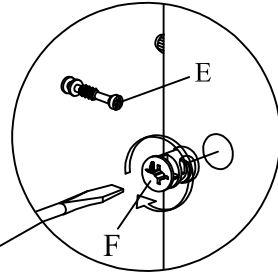

**\*Assemble right size panel (2), secure with Minifix as shown.**

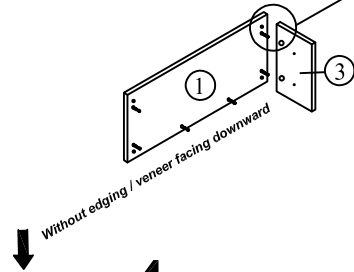

**x4**

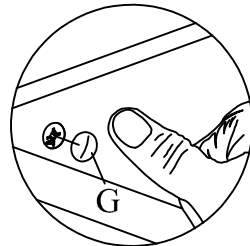

**\*Attach Minifix Cap as shown.**

Step 6

This is how a mini fix works...



The head of the mini fix housing goes into the open mouth of the mini fix bolt. You then turn the mini fix housing so it tightens over the mini fix bolt.

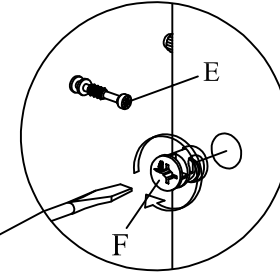

**\*Assemble right size panel (2), secure with Minifix as shown.**

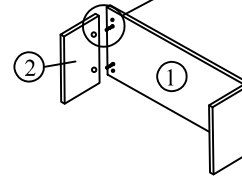

**x4**

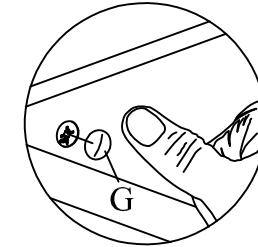

**\*Attach Minifix Cap as shown.**

Step 7

This is how a mini fix works...



The head of the mini fix housing goes into the open mouth of the mini fix bolt. You then turn the mini fix housing so it tightens over the mini fix bolt.

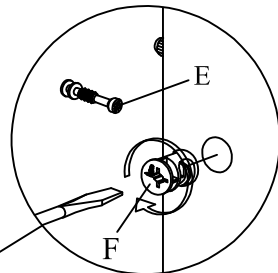

**\*Assemble back size panel (3), secure with Minifix as shown.**

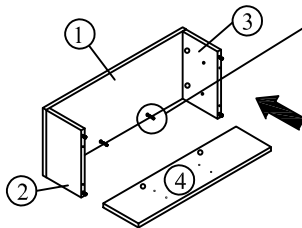

**x4**

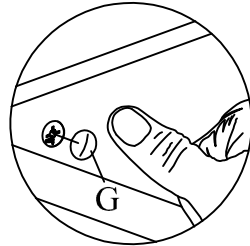

**\*Attach Minifix Cap as shown.**

Step 8

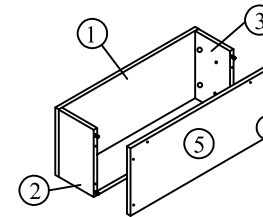

**x4**

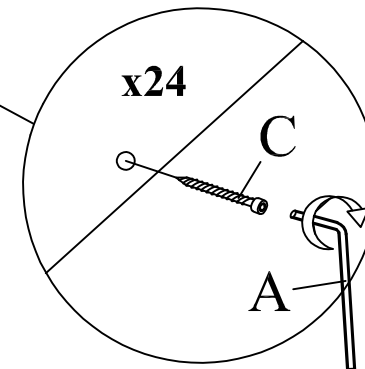

Step 9

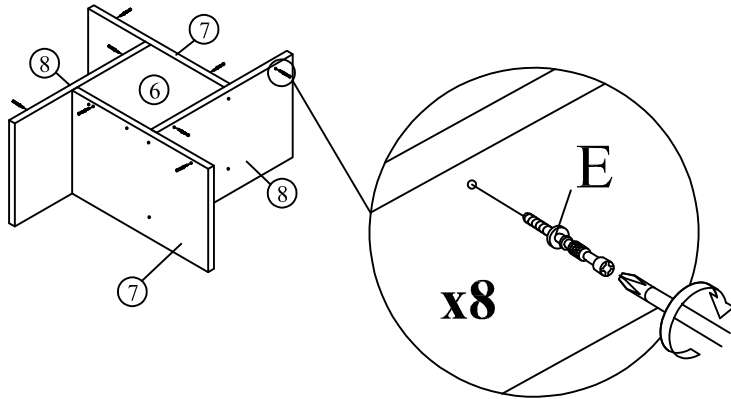

Step 10

This is how a mini fix works...



The head of the mini fix housing goes into the open mouth of the mini fix bolt. You then turn the mini fix housing so it tightens over the mini fix bolt.

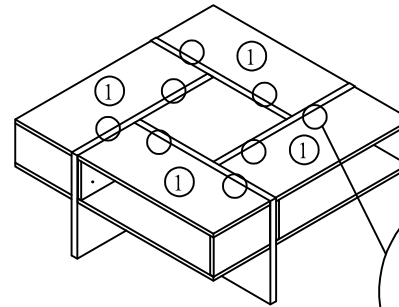

x4

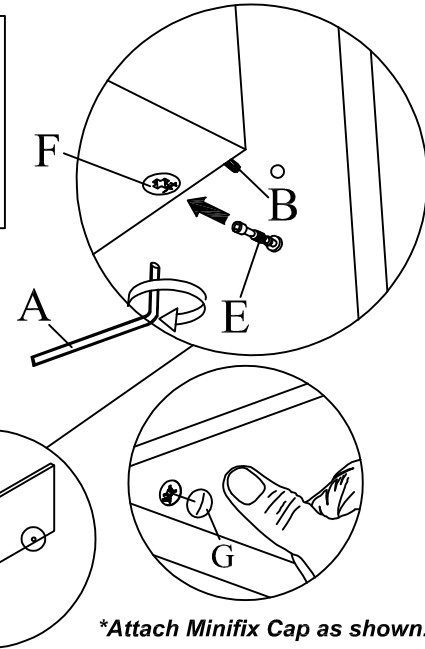

\*Attach Minifix Cap as shown.

Step 11

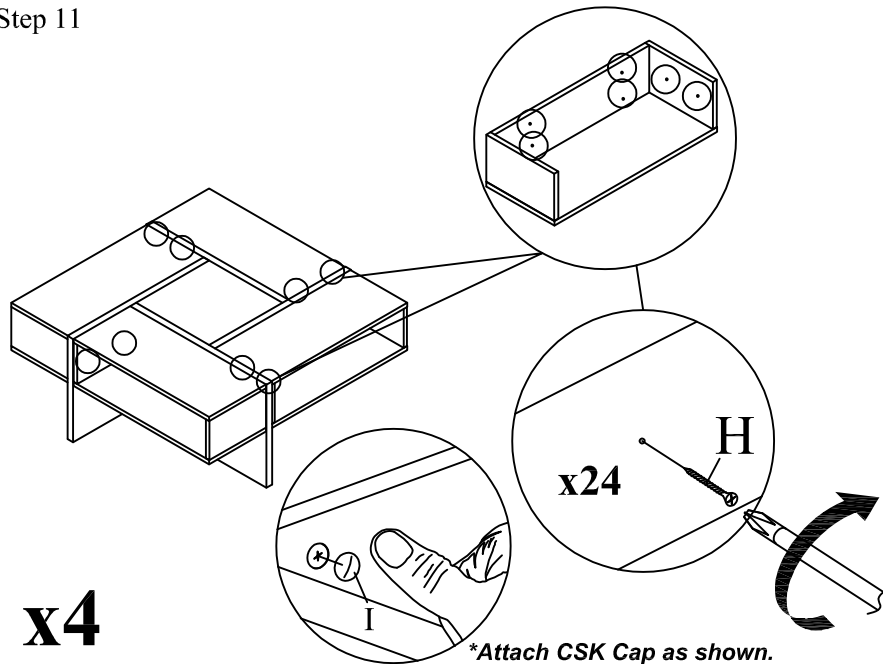

x4

\*Attach CSK Cap as shown.

Step 12

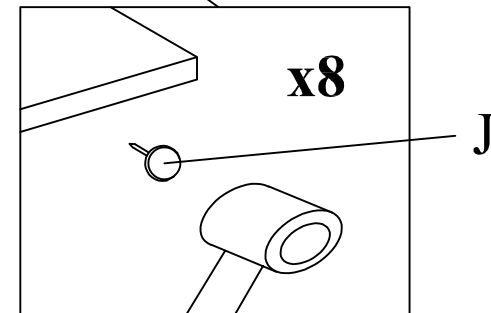
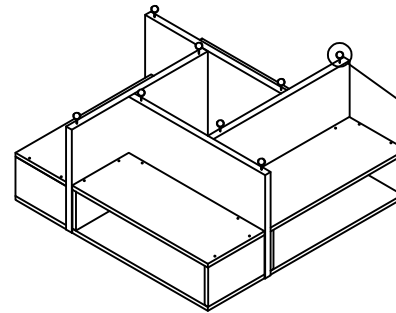

x8

J