

# ASSEMBLY INSTRUCTIONS

Read this instruction carefully. See hardware and furniture part list for guidance. Be sure all parts are complete, before you assemble. Place all wooden furniture parts on a clean and flat soft surface to prevent from being scratched. Follow the figure to start assembling.

- CAUTIONS :**
1. Do not FULLY - TIGHTEN the nut or nut bolt until all nut or bolt is ready assembled.
  2. Do not OVER - TIGHTEN the nut or bolt to avoid causing damages to the thread.
  3. Keep all hardware parts out of reach of children.
  4. Strictly no power drill to assemble. Use only the screwdrivers for installation to protect the wood frame.

**NOTE :** THE LIST AND QUANTITY SHOWN ARE FOR 1 UNIT ASSEMBLY.  
Tool needed : Screwdriver & Rubber Mallet (not provider).

PART LIST		
ITEM	DESCRIPTION	QTY
A	ARM (L&R)	2 PCS
B	BACK (L&R)	1 PC
C	CUSHION SEAT	3 PCS
D	SUPPORT RAIL	2 PCS
E	BOARD	1 PC
F	CENTER RAIL	3 PCS
G	CENTER RAIL LEG	1 PC
H	CUSHION BACK	3PCS

HARDWARE LIST		
ITEM	DESCRIPTION	QTY
1	JCBC BOLT M6 x 40mm	2 PCS
2	M6 FLAT WASHER	2 PCS
3	M6 SPRING WASHER	2 PCS
4	JCBB BOLT M8 x 40mm	4 PCS
5	M8 SPRING WASHER	4 PCS
6	WOOD SCREW M4 x 32mm	12 PCS
7	WOOD SCREW M4 x 38mm	6 PCS
8	WOOD DOWEL M10 x 30mm	20 PCS
9	WOOD BUTTON DIA 18.5mm	4 PCS
10	M4 ALLEN KEY (BALL SHAPE)	1 PC
11	M5 ALLEN KEY (BALL SHAPE)	1 PC

## STEP 1

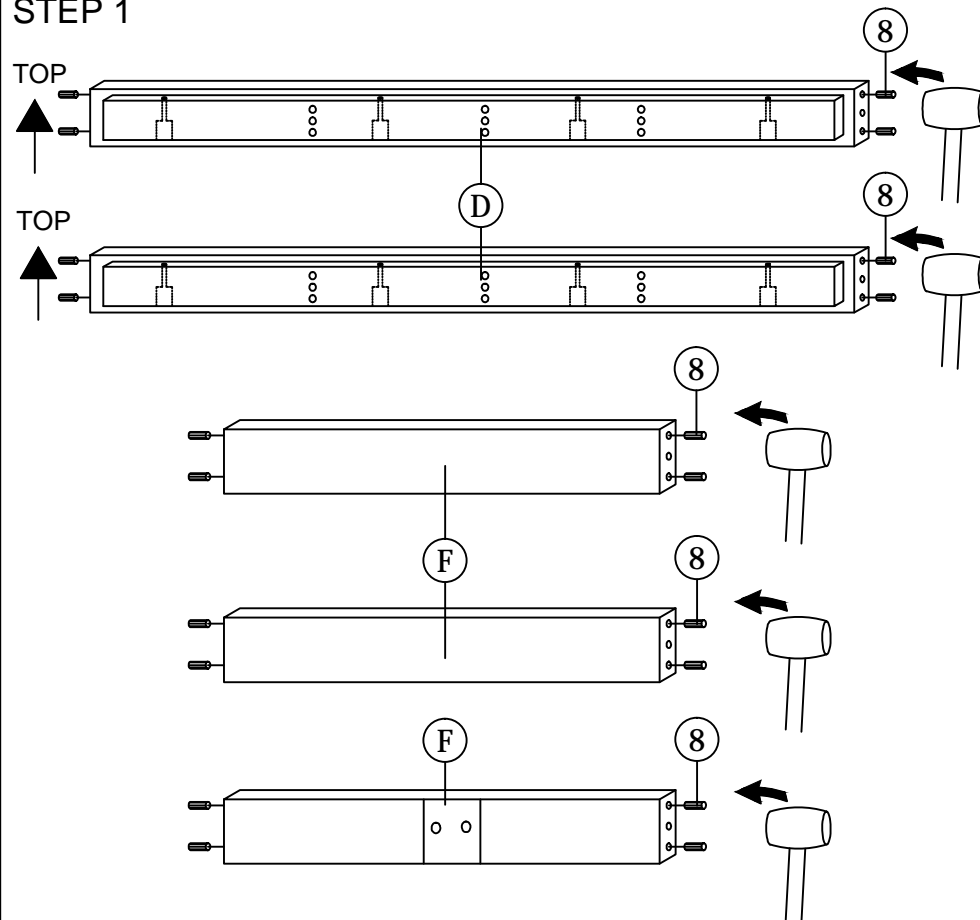

## STEP 2

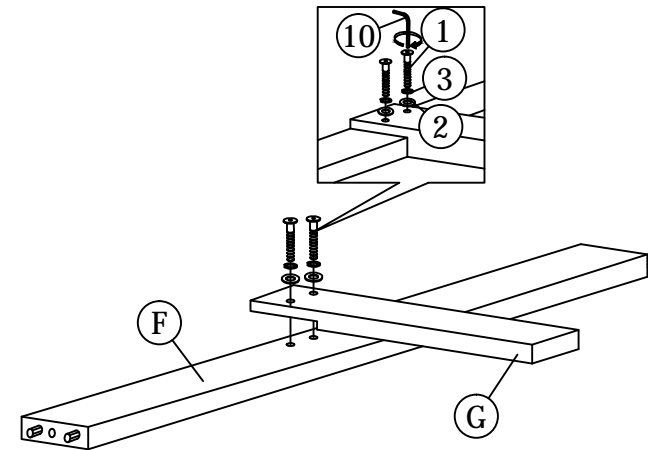

## STEP 3

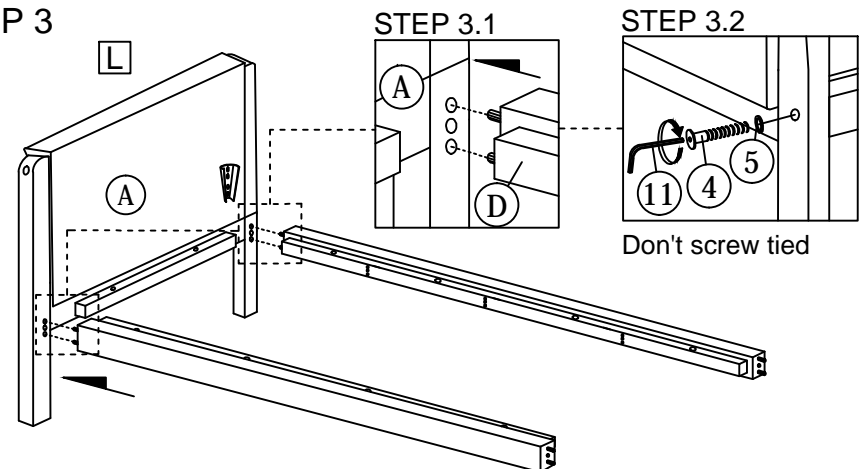

# ASSEMBLY INSTRUCTIONS

## STEP 4

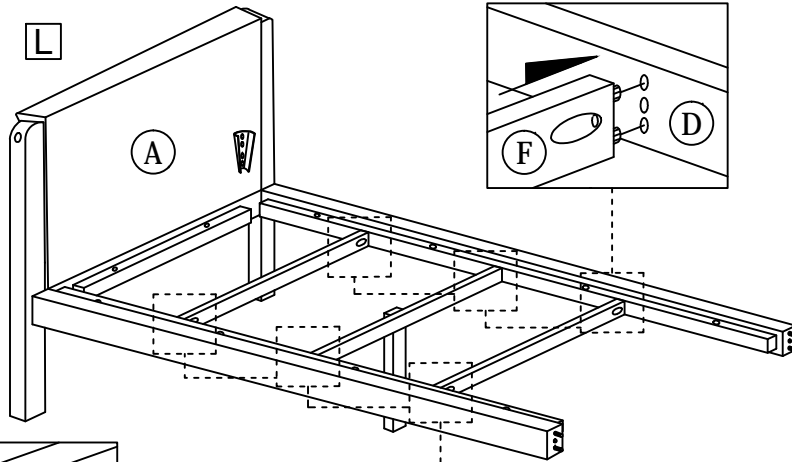

### STEP 4.1

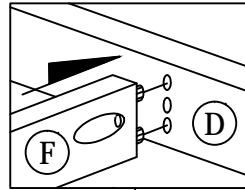

### STEP 4.2

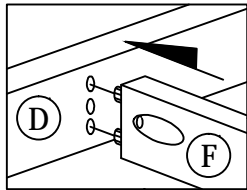

## STEP 5

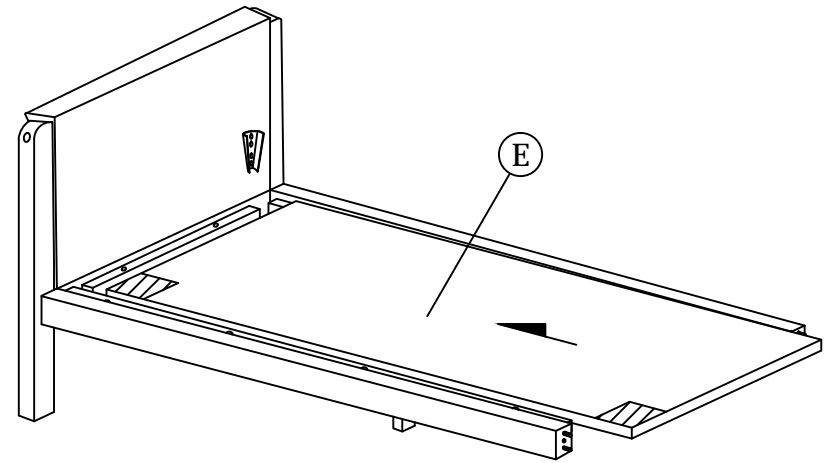

## STEP 6

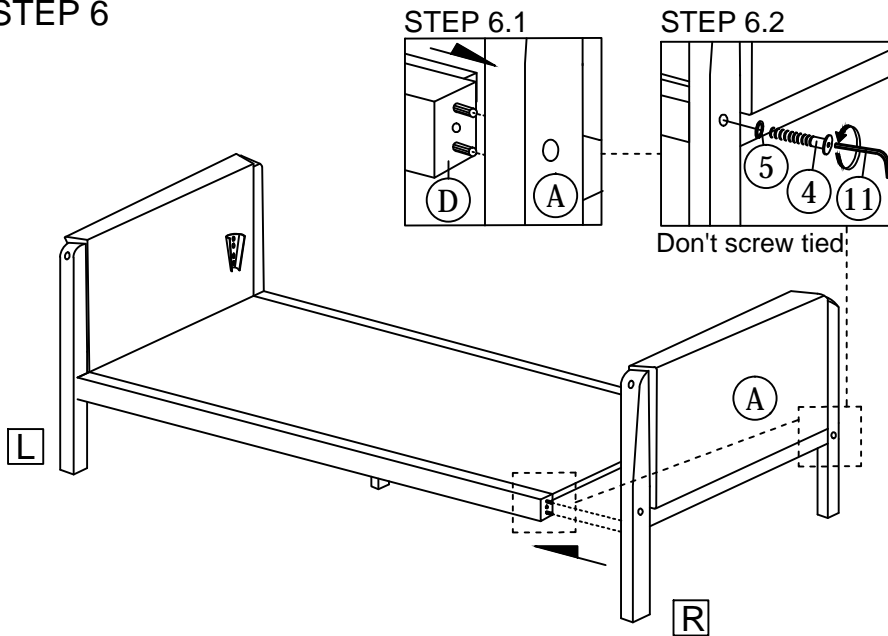

### STEP 6.1

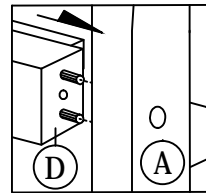

### STEP 6.2

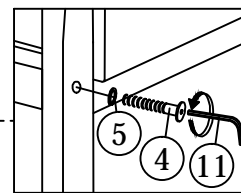

Don't screw tied.

## STEP 7

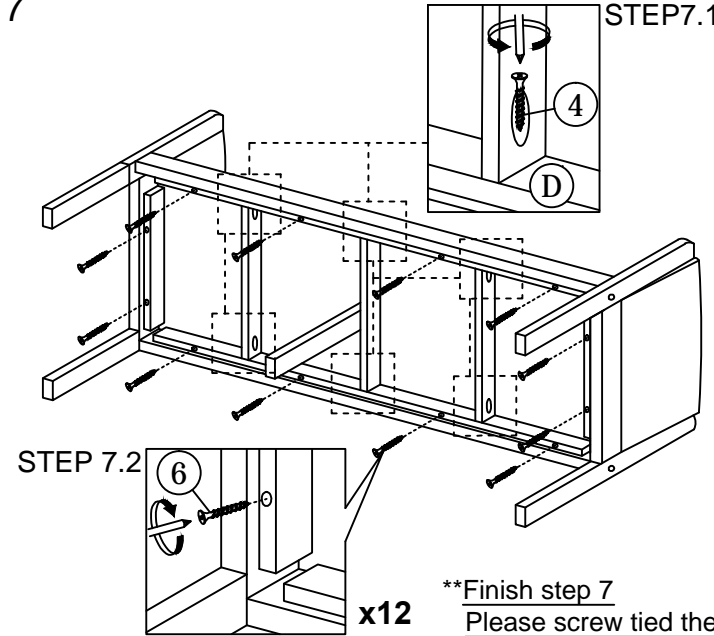

### STEP 7.1

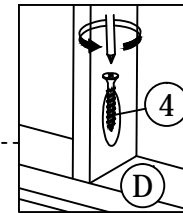

### STEP 7.2

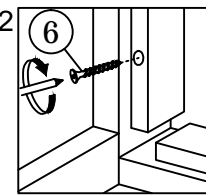

x12

\*\*Finish step 7  
Please screw tied the step 3,6 bolt.

# ASSEMBLY INSTRUCTIONS

STEP 8

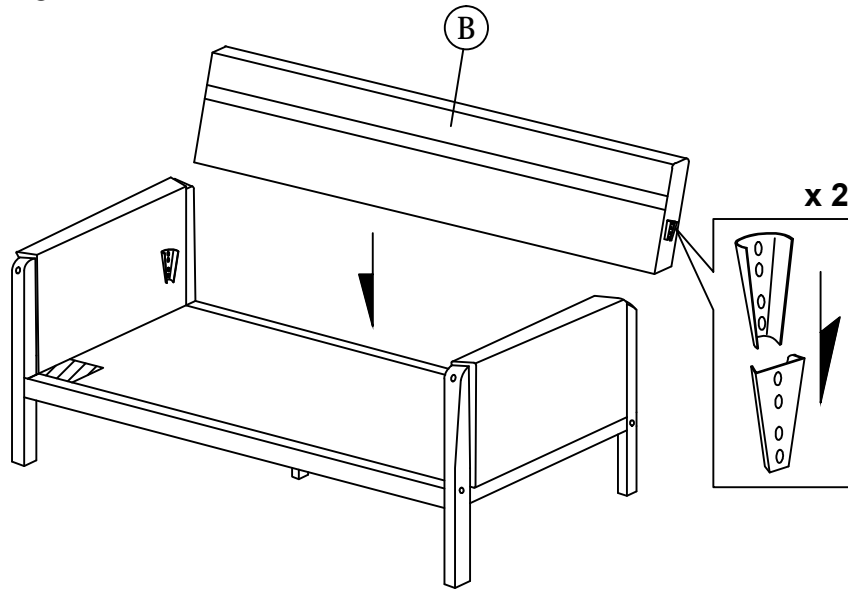

STEP 9

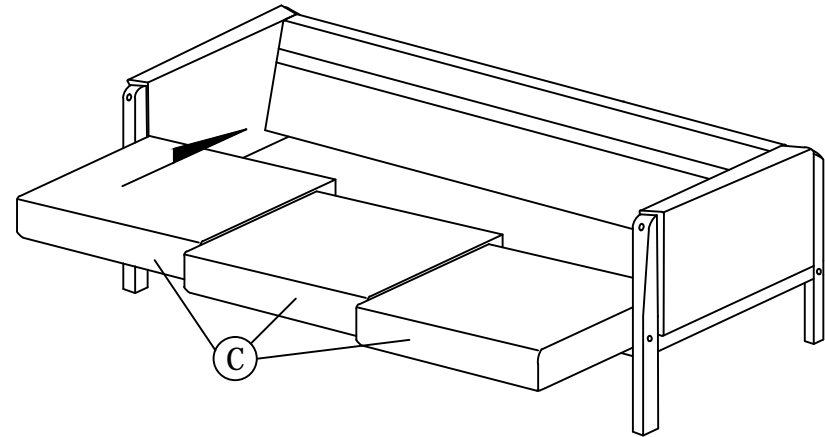

STEP 10

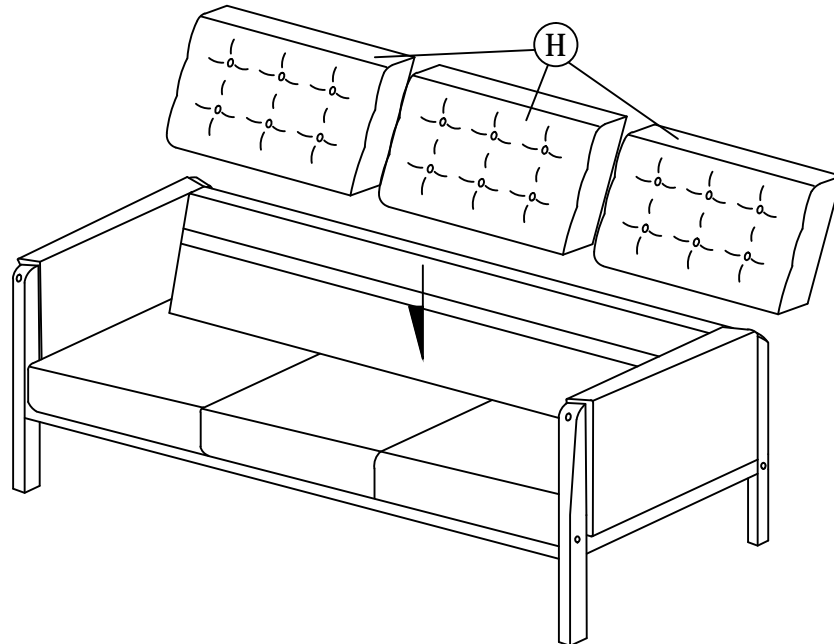

# ASSEMBLY INSTRUCTIONS

## STEP 11

STEP 11.1 **x 2**

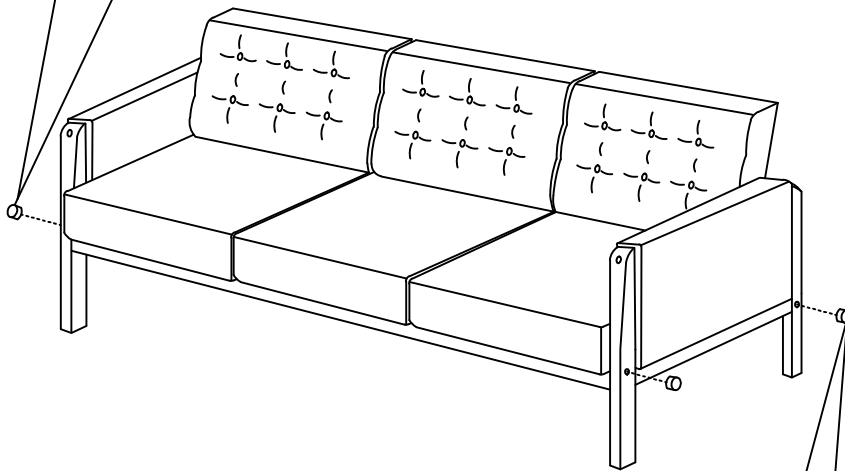
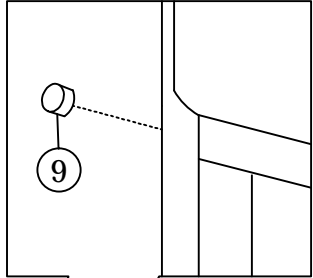

**x 2**

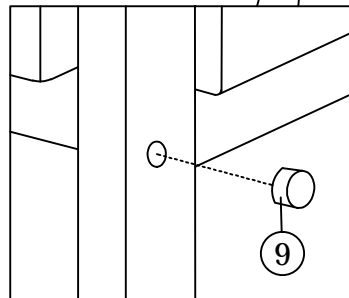

STEP 11.2

## STEP 12

