

Read this instruction carefully. See hardware and furniture part list for guidance. Be sure all parts are complete, before you assemble. Place all wooden furniture parts on a clean and flat soft surface to prevent from being scratched. Follow the figure to start assembling.

CAUTIONS : 1. Do not FULLY - TIGHTEN the nut or nut bolt until all nut or bolt is ready assembled.
 2. Do not OVER - TIGHTEN the nut or bolt to avoid causing damages to the thread.
 3. Keep all hardware parts out of reach of children.

NOTE : THE LIST AND QUANTITY SHOWN ARE FOR 1 UNIT ASSEMBLY.

Tool needed : Screwdriver (not provider).

| PART LIST | | |
|-----------|---------------------|--------|
| ITEM | DESCRIPTION | QTY |
| A | HEADBOARD | 1 PC |
| B | FOOTBOARD | 1 PC |
| C | SIDE RAIL | 2 PCS |
| D | CENTER RAIL | 1 PC |
| E | CENTER RAIL SUPPORT | 2 PCS |
| F | CENTER RAIL LEG | 3 PCS |
| G | LEG | 4 PCS |
| H | BED SLAT | 24 PCS |

| HARDWARE LIST | | |
|---------------|---------------------------|--------|
| ITEM | DESCRIPTION | QTY |
| 1 | WOOD SCREW M4 x 20mm | 2 PCS |
| 2 | WOOD SCREW M3.5 x 16mm | 8 PCS |
| 3 | M5 ALLEN KEY (BALL SHAPE) | 1 PCS |
| 4 | BED SLAT SIDE FITTER | 24 PCS |
| 5 | BED SLAT CENTER FITTER | 12 PCS |

STEP 1

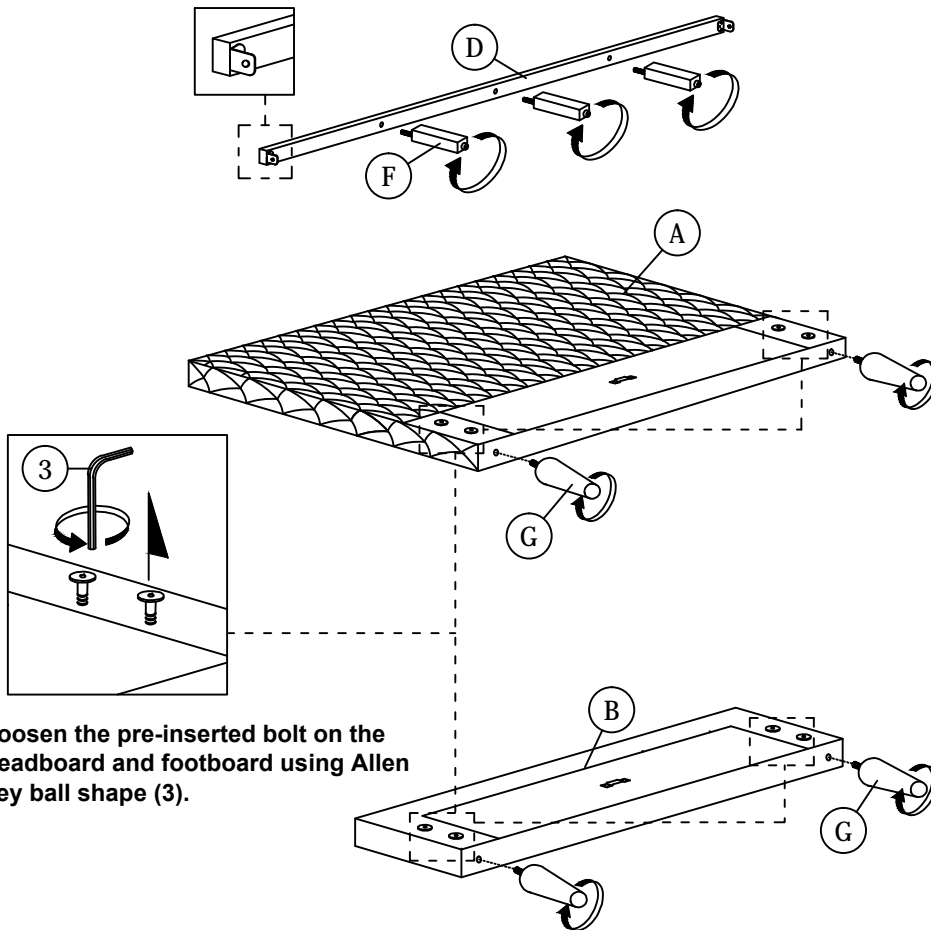

STEP 2

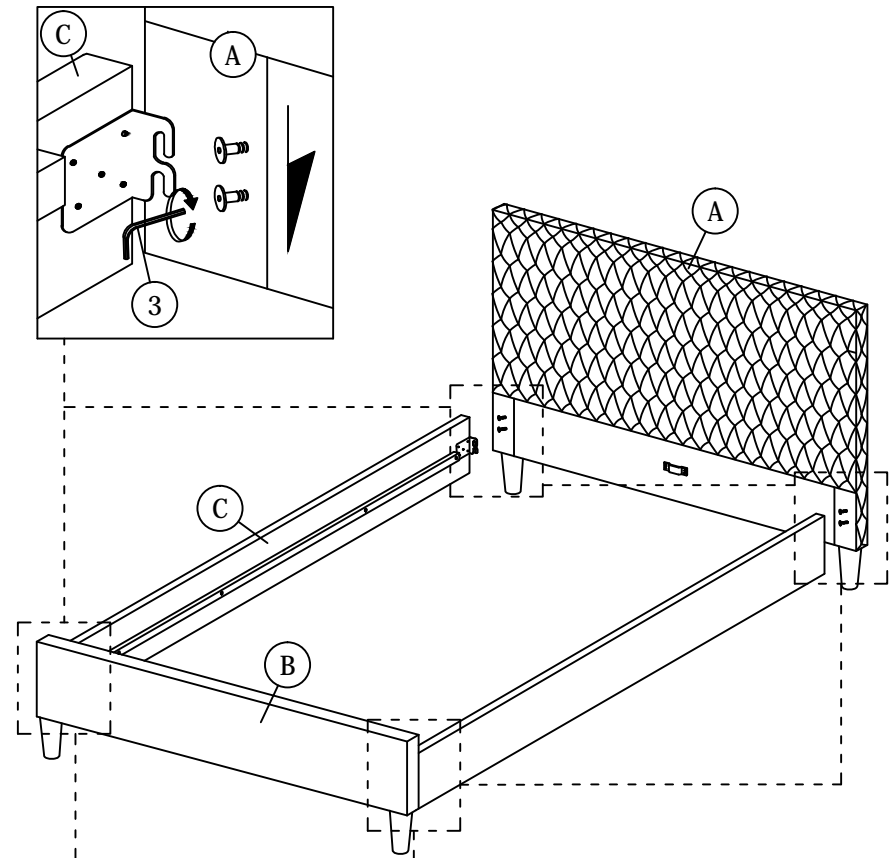

ASSEMBLY INSTRUCTIONS

STEP 3

STEP 3.1

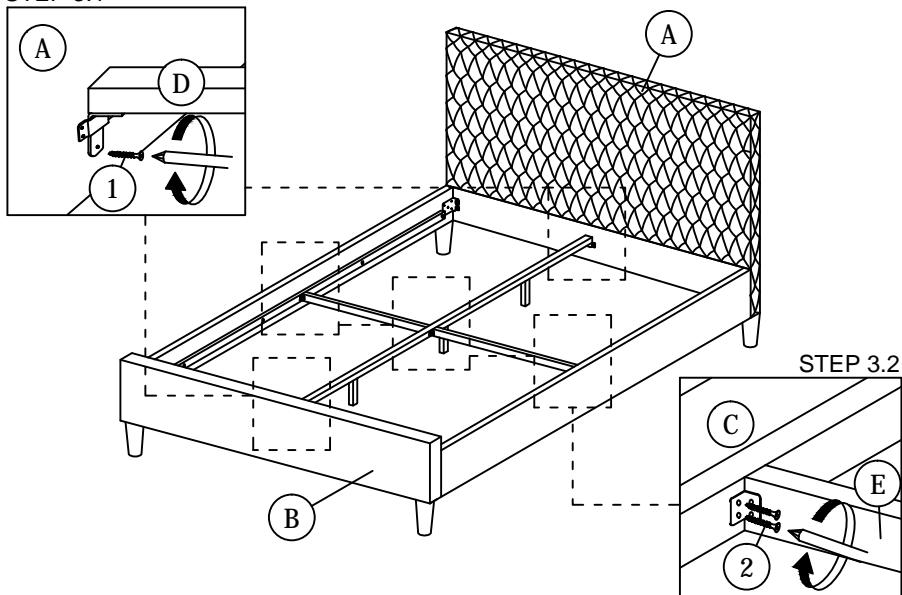

STEP 4

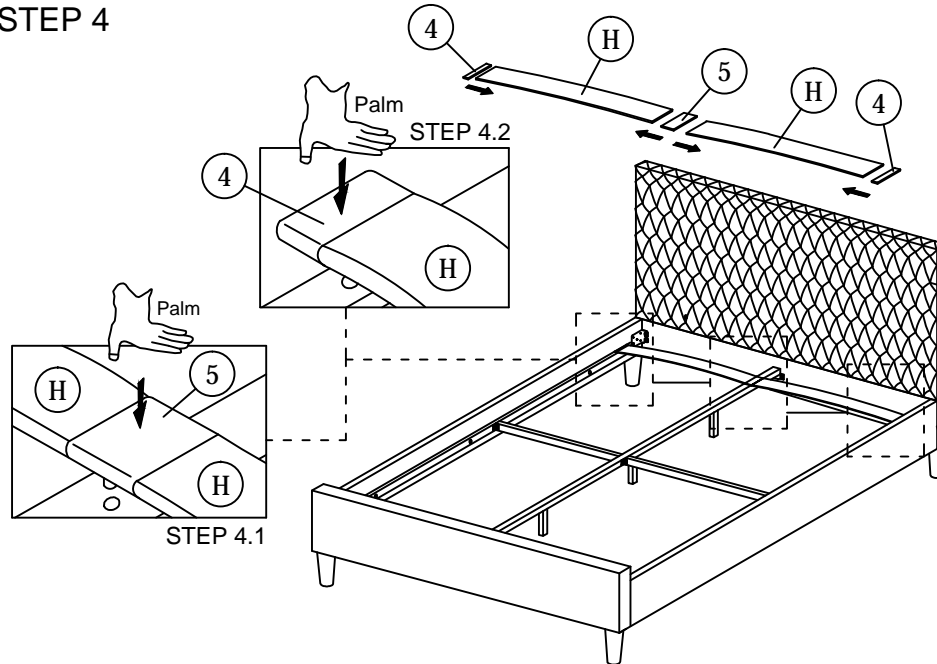

STEP 5

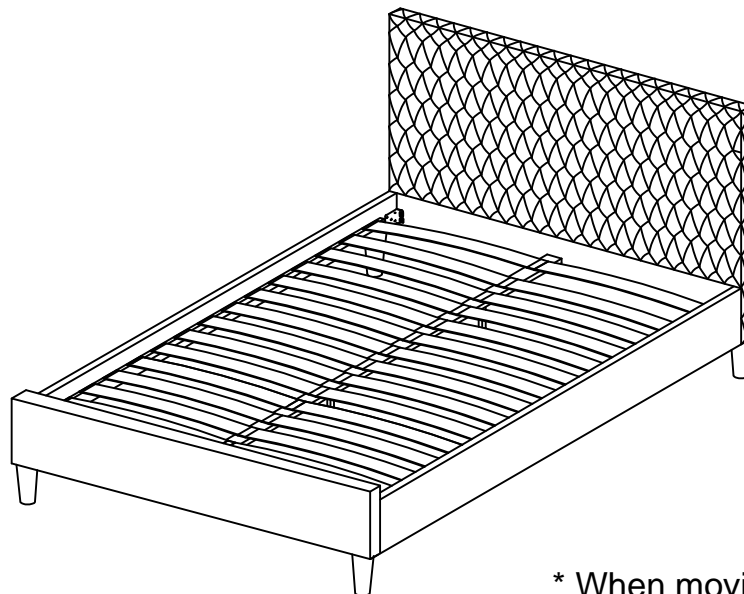

* When moving the bed position, the center support legs must be adjust to be straight to avoid any broken problem.