

Read this instruction carefully. See hardware and furniture part list for guidance. Be sure all parts are complete, before you assemble. Place all wooden furniture parts on a clean and flat soft surface to prevent from being scratched. Follow the figure to start assembling.

CAUTIONS : 1. Do not FULLY - TIGHTEN the nut or nut bolt until all nut or bolt is ready assembled.
 2. Do not OVER - TIGHTEN the nut or bolt to avoid causing damages to the thread.
 3. Keep all hardware parts out of reach of children.

NOTE : THE LIST AND QUANTITY SHOWN ARE FOR 1 UNIT ASSEMBLY

PART LIST		
ITEM	DESCRIPTION	QTY
A	HEADBOARD	1 PC
B	HEADBOARD LEG (L)	1 PC
C	HEADBOARD LEG (R)	1 PC
D	HEADBOARD SUPPORT RAIL	1 PC
E	FOOTBOARD	1 PC
F	SIDE RAIL (L)	2 PCS
G	SIDE RAIL (R)	2 PCS
H	CENTER SUPPORT WOOD	4 PCS
I	CENTER LEG	4 PCS
J	BED LEG	4 PCS

HARDWARE LIST		
ITEM	DESCRIPTION	QTY
1	JCBC BOLT M6 x 20mm	4 PCS
2	JCBC BOLT M6 x 30mm	16 PCS
3	JCBC BOLT M6 x 35mm	12 PCS
4	JCBB BOLT M8 x 50mm	6 PCS
5	M6 SPRING WASHER	20 PCS
6	M6 FLAT WASHER	20 PCS
7	M8 SPRING WASHER	6 PCS
8	M8 FLAT WASHER	6 PCS
9	M4 ALLEN KEY (BALL SHAPE)	1 PC
10	M5 ALLEN KEY (BALL SHAPE)	1 PC
11	SHEET METAL (VMB 3076)	2 PCS

STEP 1

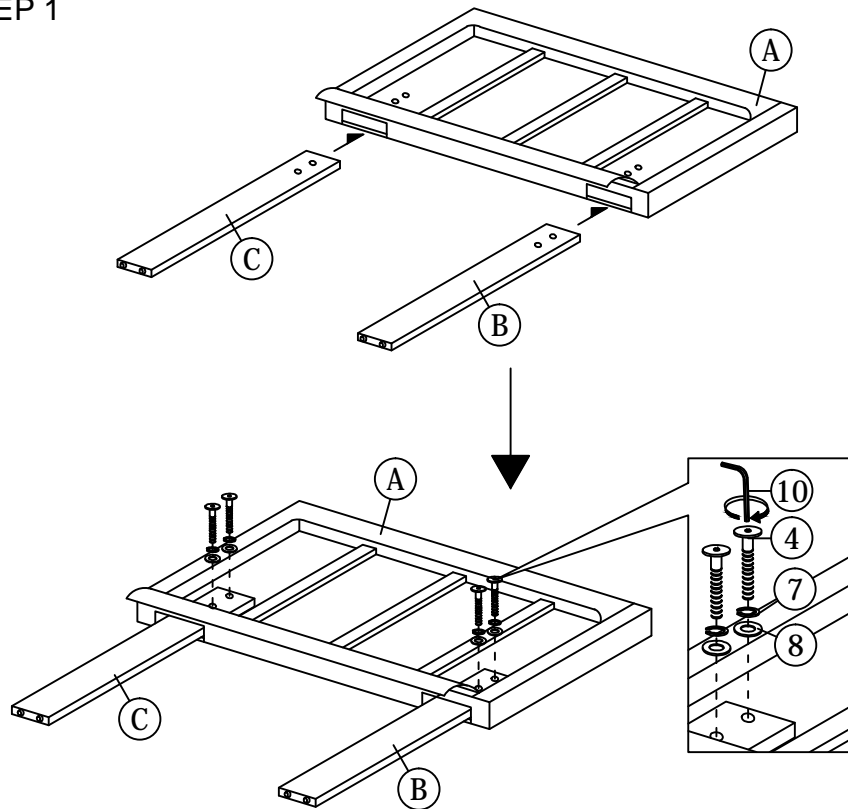

STEP 2

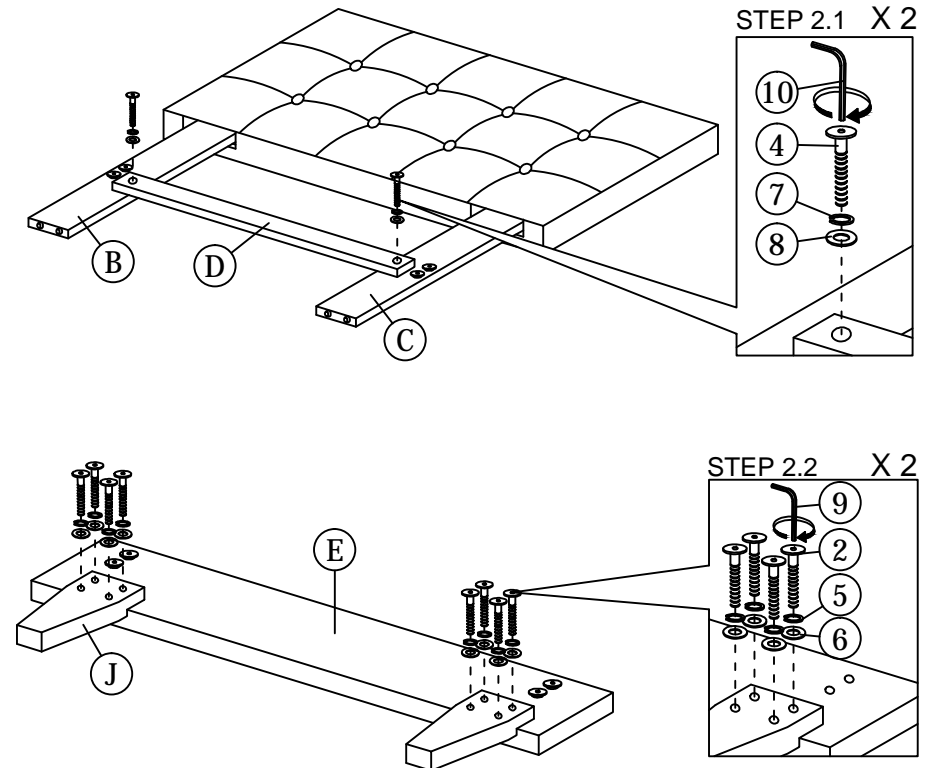

ASSEMBLY INSTRUCTIONS

STEP 3

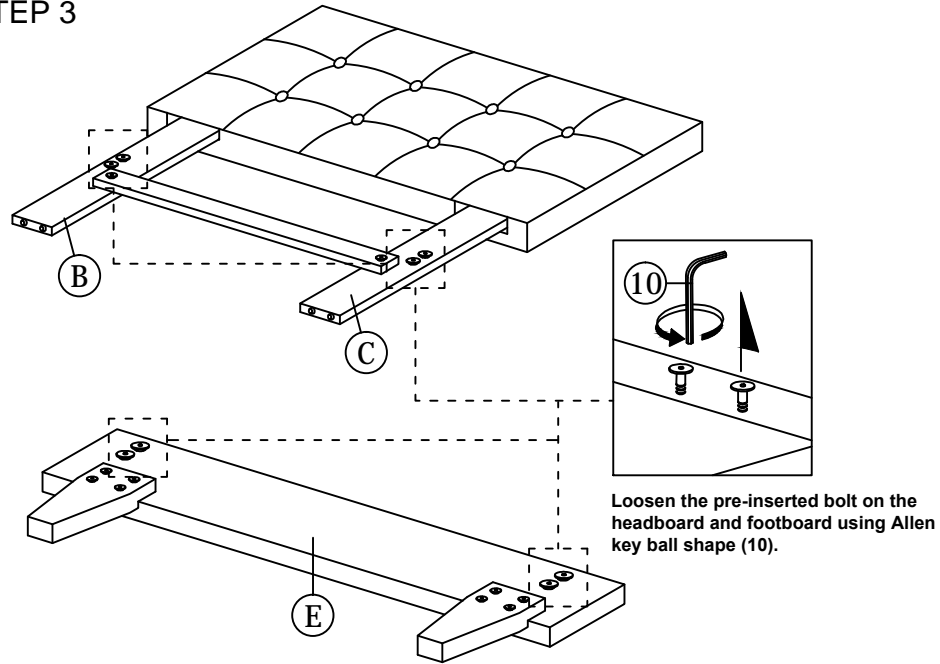

STEP 4

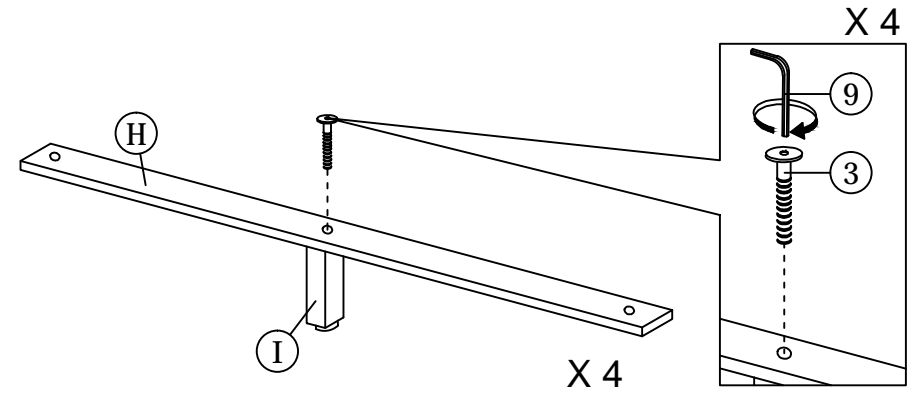

STEP 5

SIDE RAIL LEFT/RIGHT

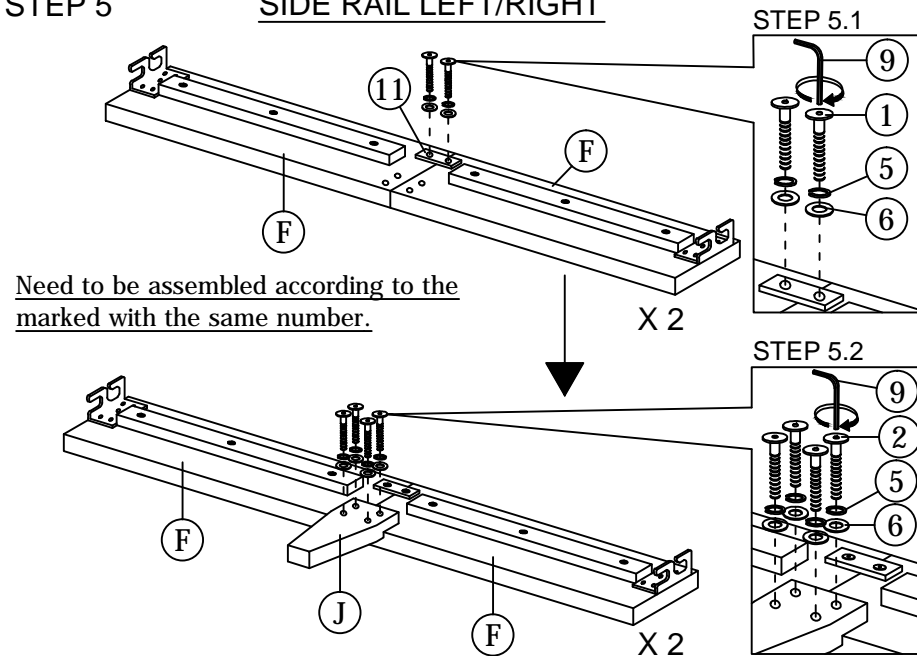

STEP 6

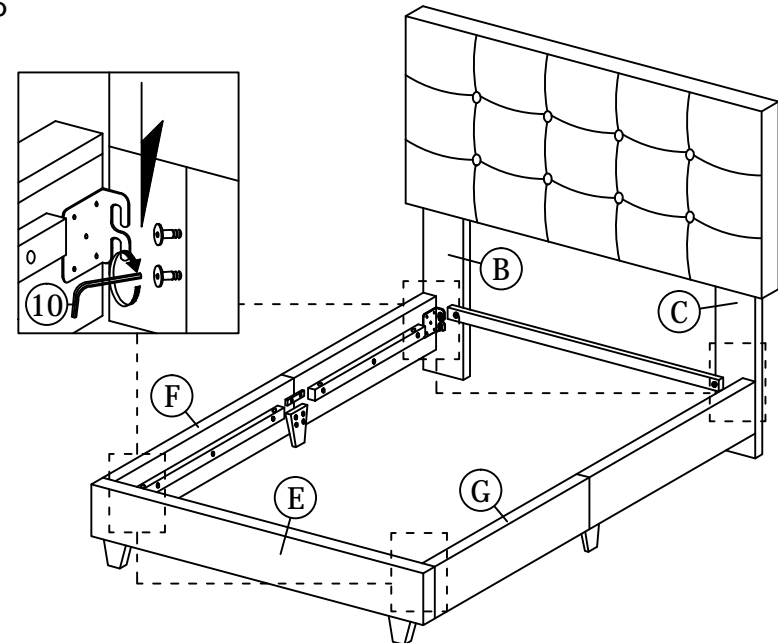

ASSEMBLY INSTRUCTIONS

STEP 7

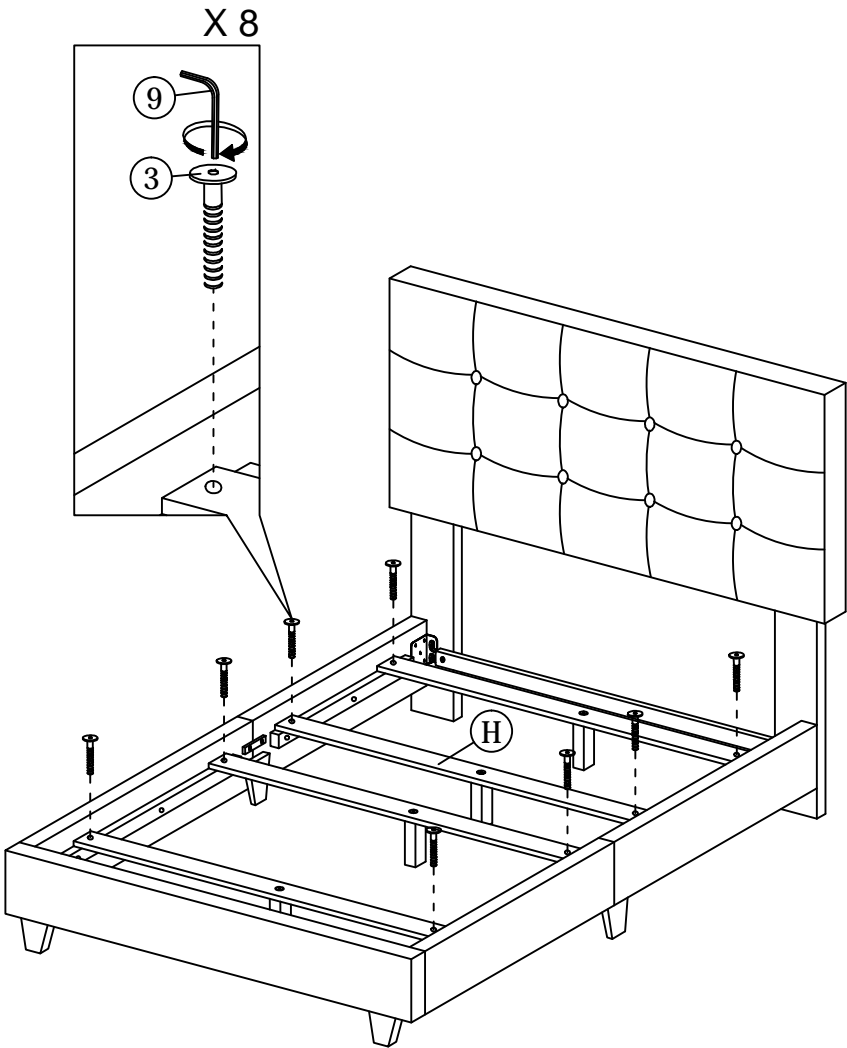

STEP 8

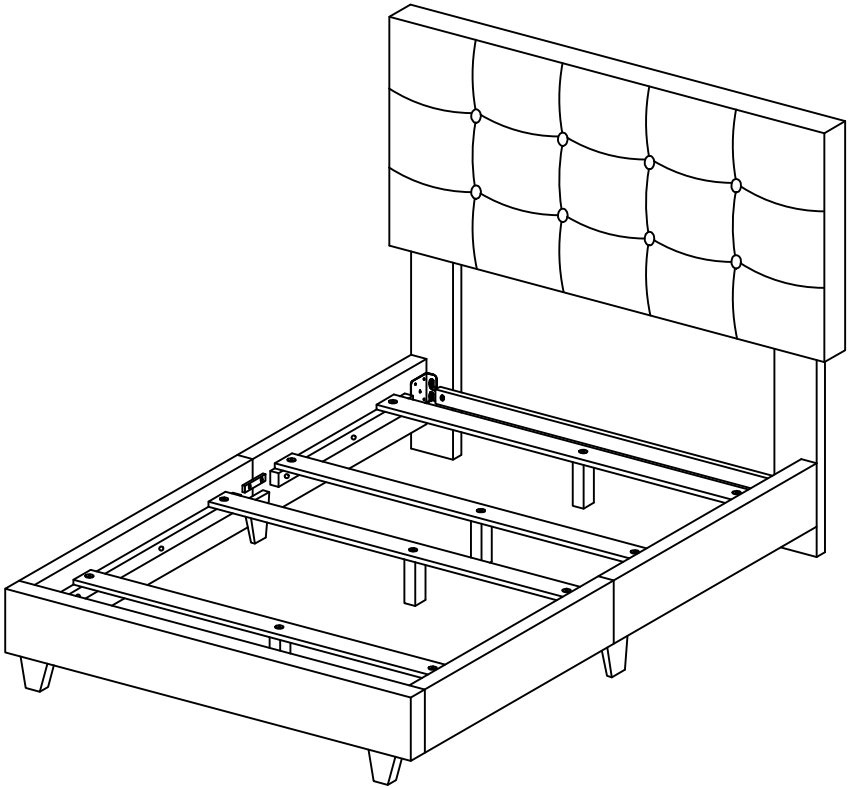

* When moving the bed position, the center support legs must be adjust to be straight to avoid any broken problem.