

Read this instruction carefully. See hardware and furniture part list for guidance. Be sure all parts are complete, before you assemble. Place all wooden furniture parts on a clean and flat soft surface to prevent from being scratched. Follow the figure to start assembling.

CAUTIONS : 1. Do not FULLY - TIGHTEN the nut or nut bolt until all nut or bolt is ready assembled.
 2. Do not OVER - TIGHTEN the nut or bolt to avoid causing damages to the thread.
 3. Keep all hardware parts out of reach of children.

NOTE : THE LIST AND QUANTITY SHOWN ARE FOR 1 UNIT ASSEMBLY.
 Tool needed : Screwdriver & Rubber Mallet (not provider).

PART LIST		
ITEM	DESCRIPTION	QTY
A	HEADBOARD	1 PC
B	HEADBOARD PANEL	1 PC
C	FOOTBOARD	1 PC
D	SIDE RAIL	2 PCS
E	CENTER RAIL	2 PCS
F	CENTER SUPPORT LEG	6 PCS
G	BED SLAT	1 SET
H	BED LEG	4 PCS
I	HEADBOARD SUPPORT WOOD	3 PCS

HARDWARE LIST		
ITEM	DESCRIPTION	QTY
1	JCBB BOLT M8 x 16mm	8 PCS
2	JCBB BOLT M8 x 35mm	8 PCS
3	JCBB BOLT M8 x 50mm	3 PCS
4	JCBB BOLT M8 x 60mm	3 PCS
5	JCBB BOLT M8 x 70mm	6 PCS
6	M8 FLAT WASHER	20 PCS
7	M8 SPRING WASHER	20 PCS
8	WOOD SCREW M4 x 32mm	12 PCS
9	WOOD DOWEL M10 x 30mm	8 PCS
10	M5 ALLEN KEY (BALL SHAPE)	1 PC

STEP 1

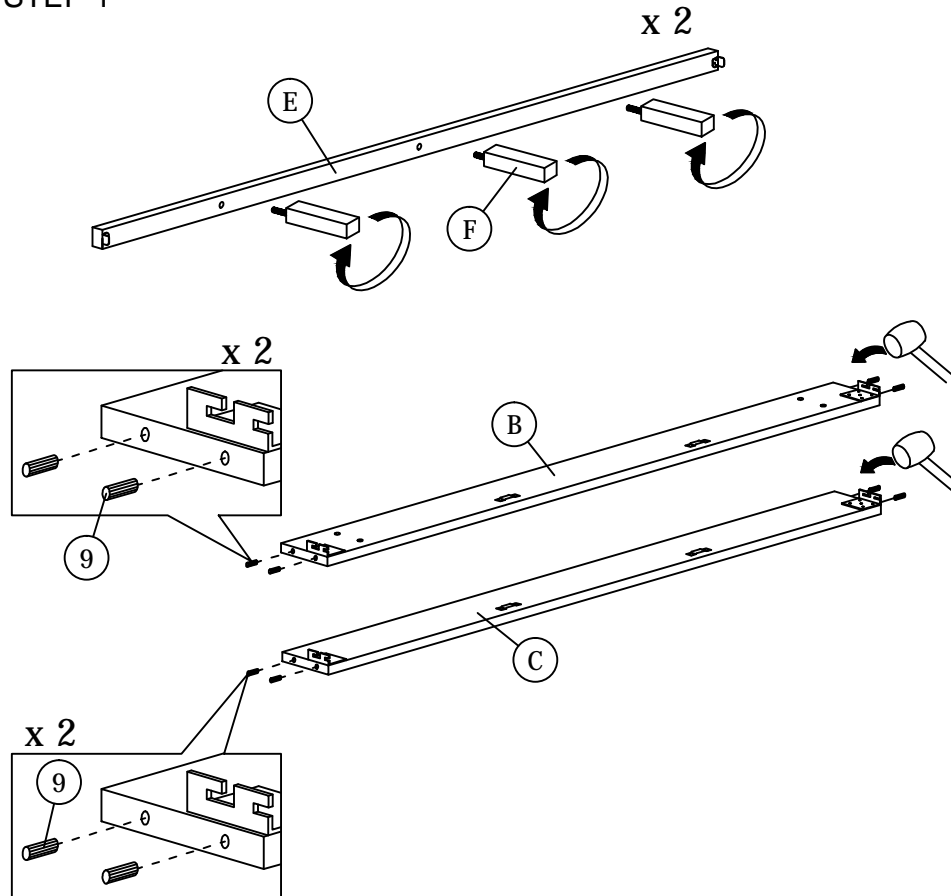

STEP 2

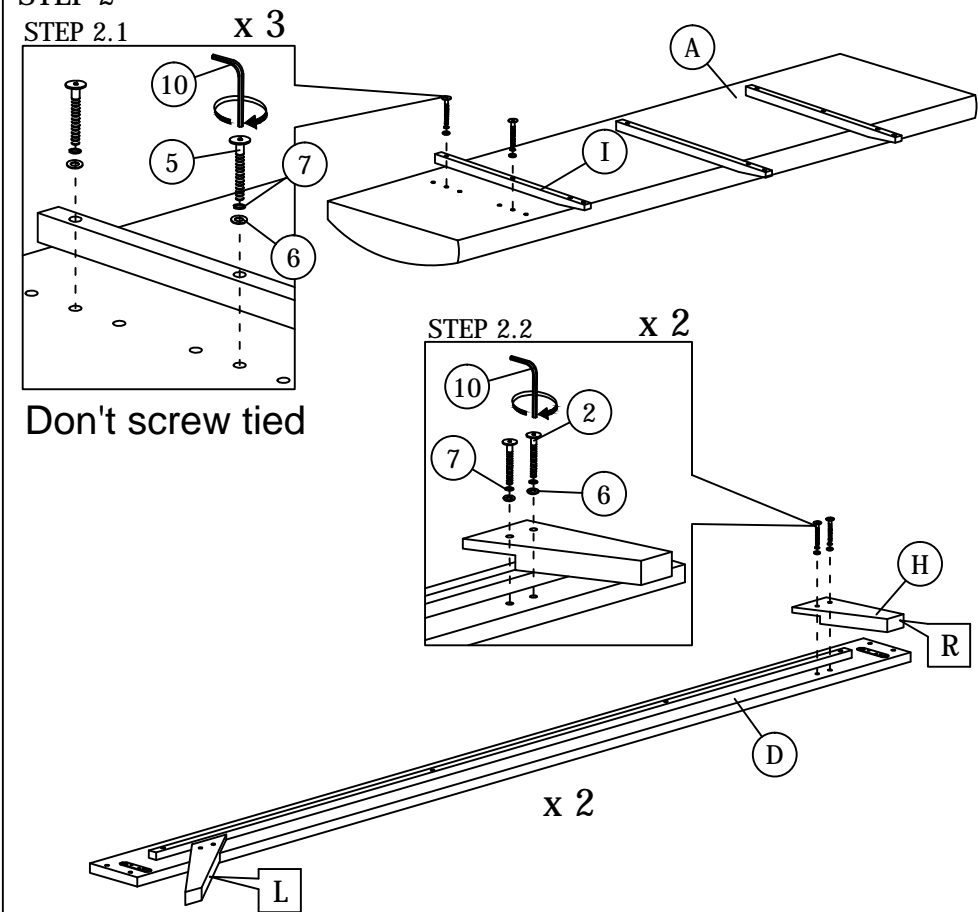

ASSEMBLY INSTRUCTIONS

STEP 3

STEP 3.2

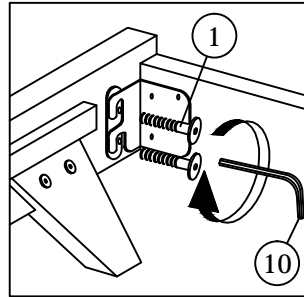

x 4

STEP 3.1

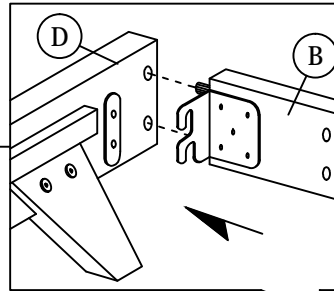

x 4

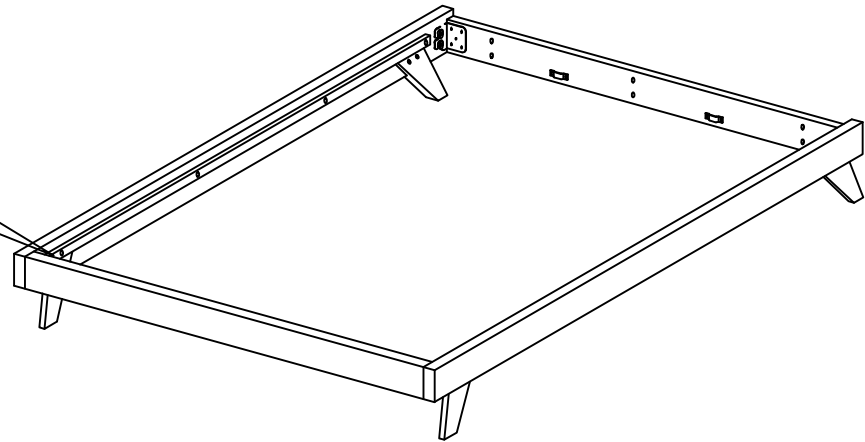

STEP 4

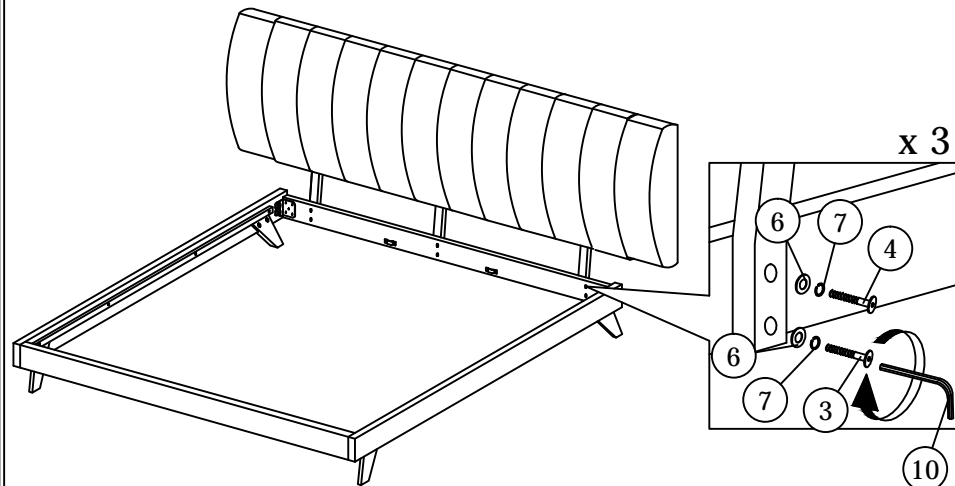

x 3

****Finish step 4,
Please screw tied the step 2 bolt.**

STEP 5

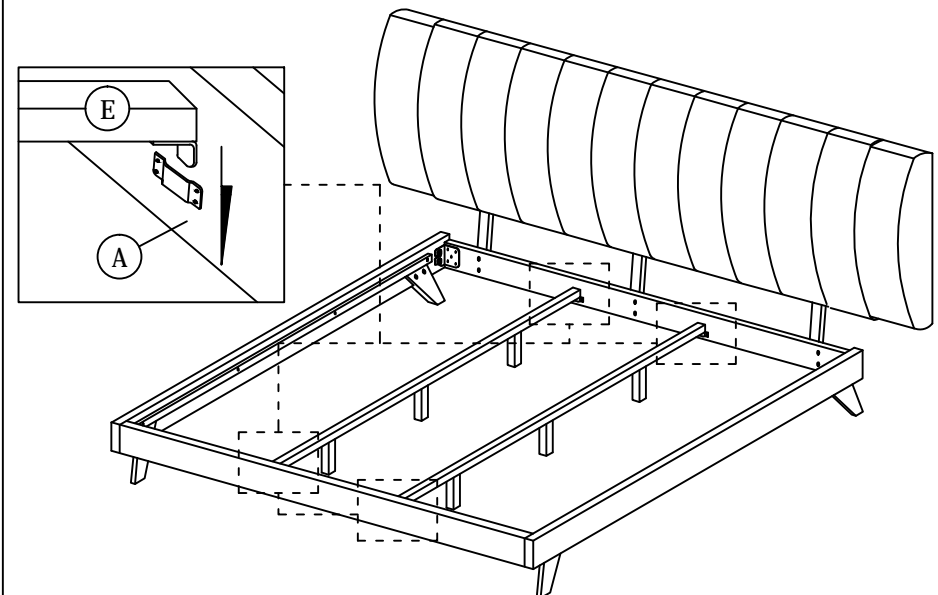

ASSEMBLY INSTRUCTIONS

STEP 6

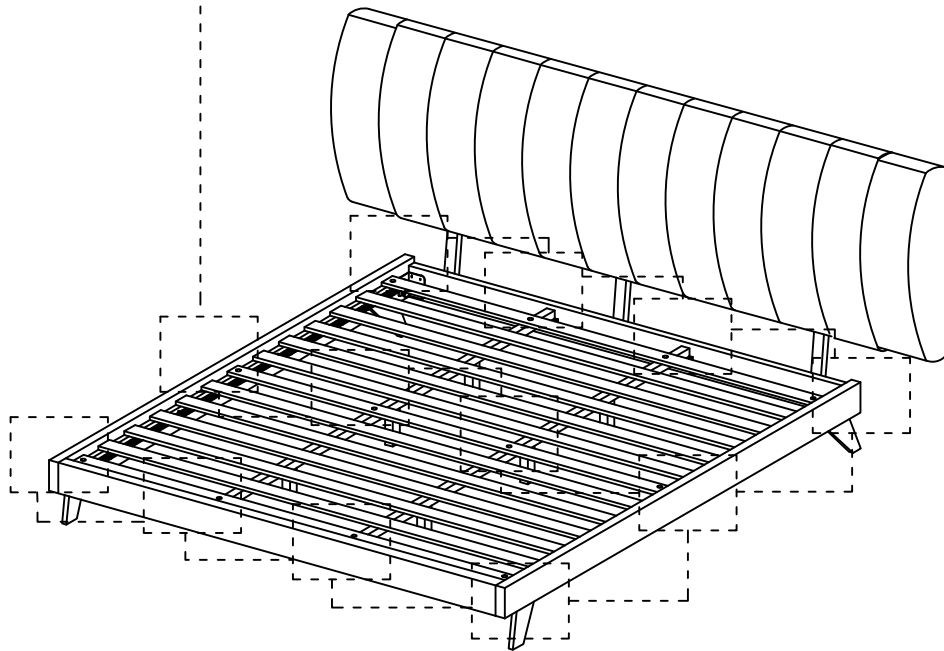
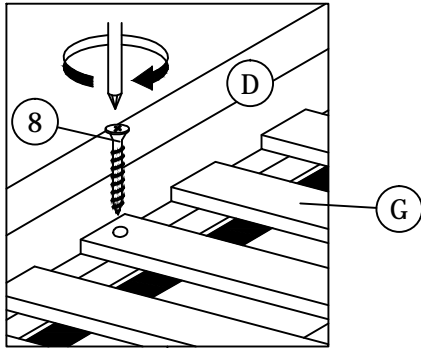

STEP 7

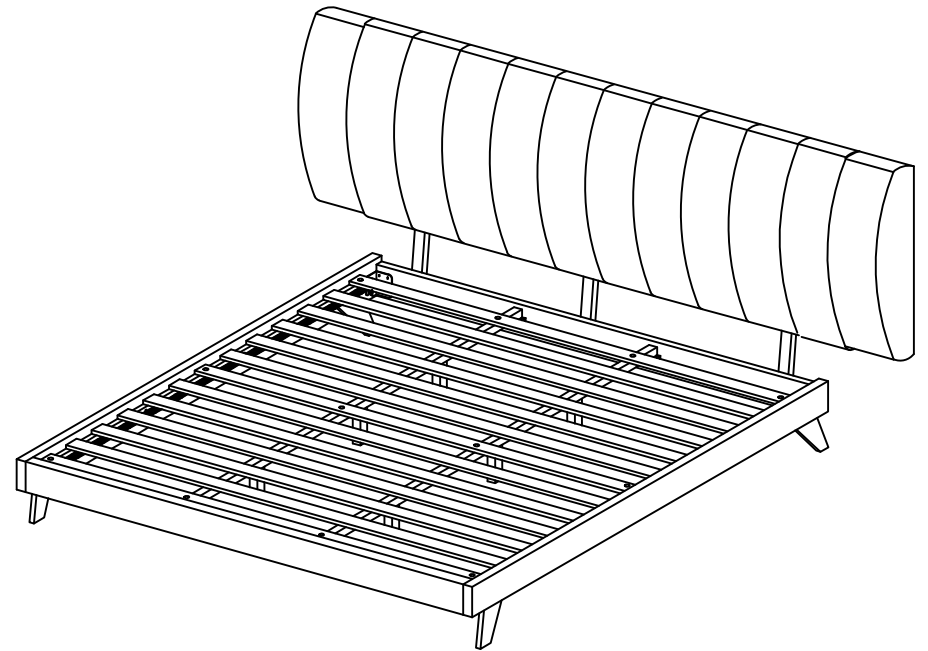

* When moving the bed position, the center support legs must be adjust to be straight to avoid any broken problem.