

1 Assembled View

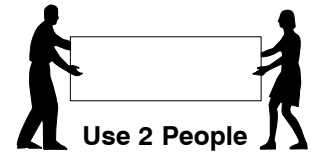

Note: Do not assemble using power tools. This can cause the bolts to be overtightened

2 Parts List

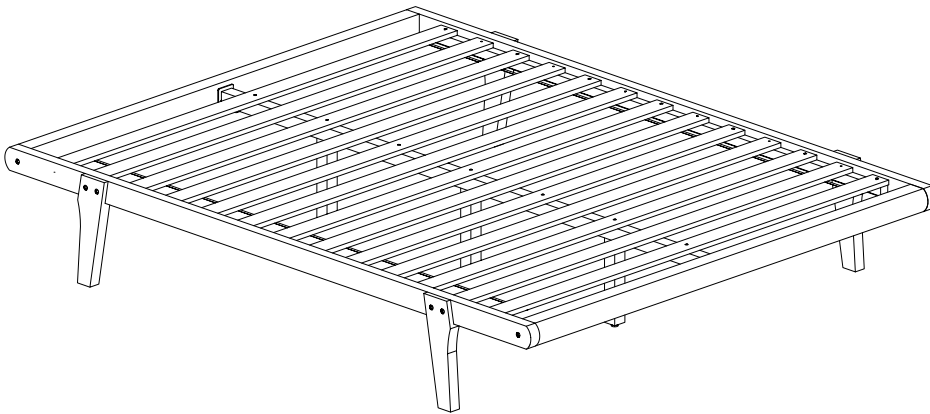
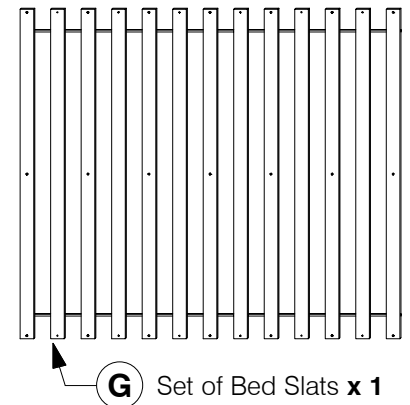
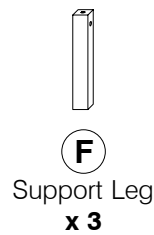
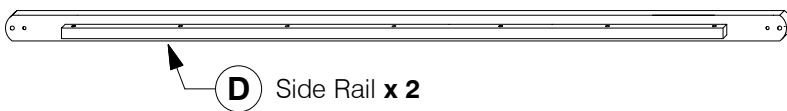
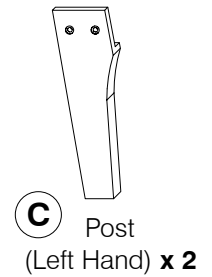
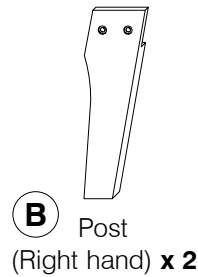
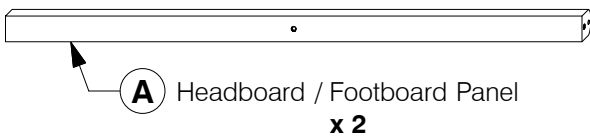

3 Hardware List



1 M6 x 100mm JCB
x 3

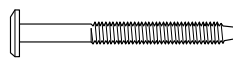

2 M6 x 60mm JCB
x 4

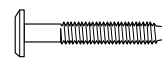

3 M6 x 40mm JCB
x 26



4 M6 x 15mm JCB
x 4



5 Barrel Nut
x 3



6 Wood Dowel
(M10 x 40mm)
x 4

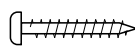

7 Wood Screw
(M4 x 32mm)
x 12

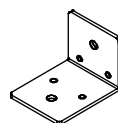

8 Center Rail
Bracket x 2



9 Allen Key
x 1

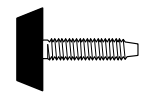

10 Adjustable
Foot x 3

4 Fix the Adjustable foot to the bottom of the Support Leg (F).

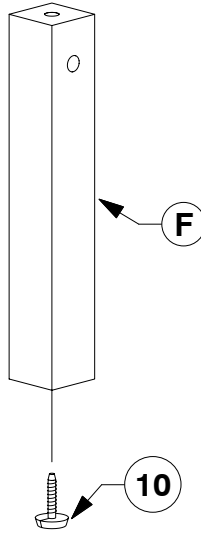

5 Fit the Center Rail Bracket to the Headboard / Footboard Panel (A).

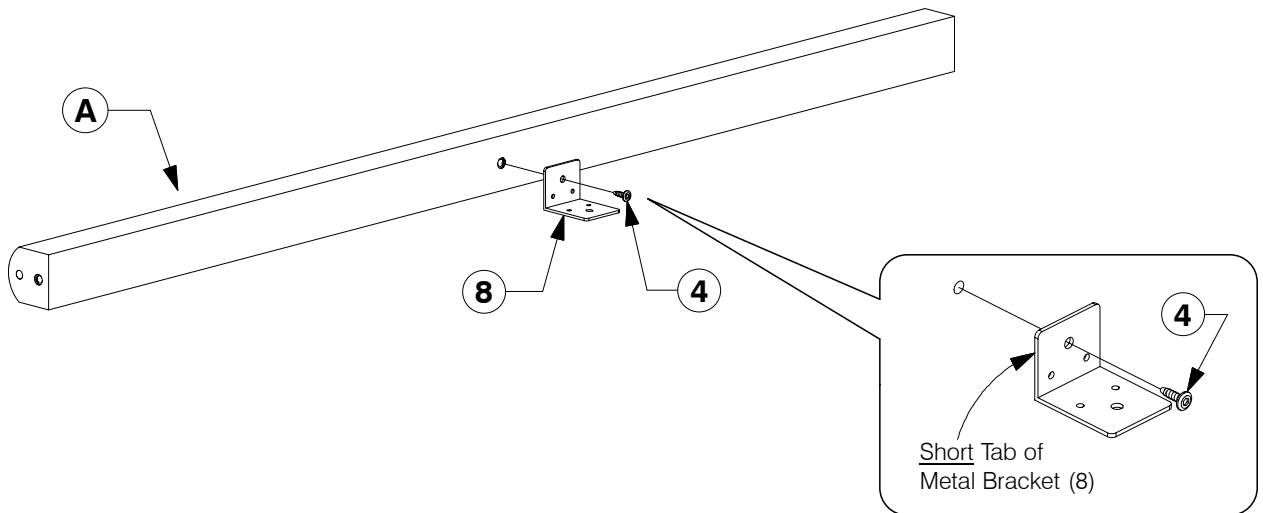

6 Assemble the Post (B & C) to the Side Rail (D).

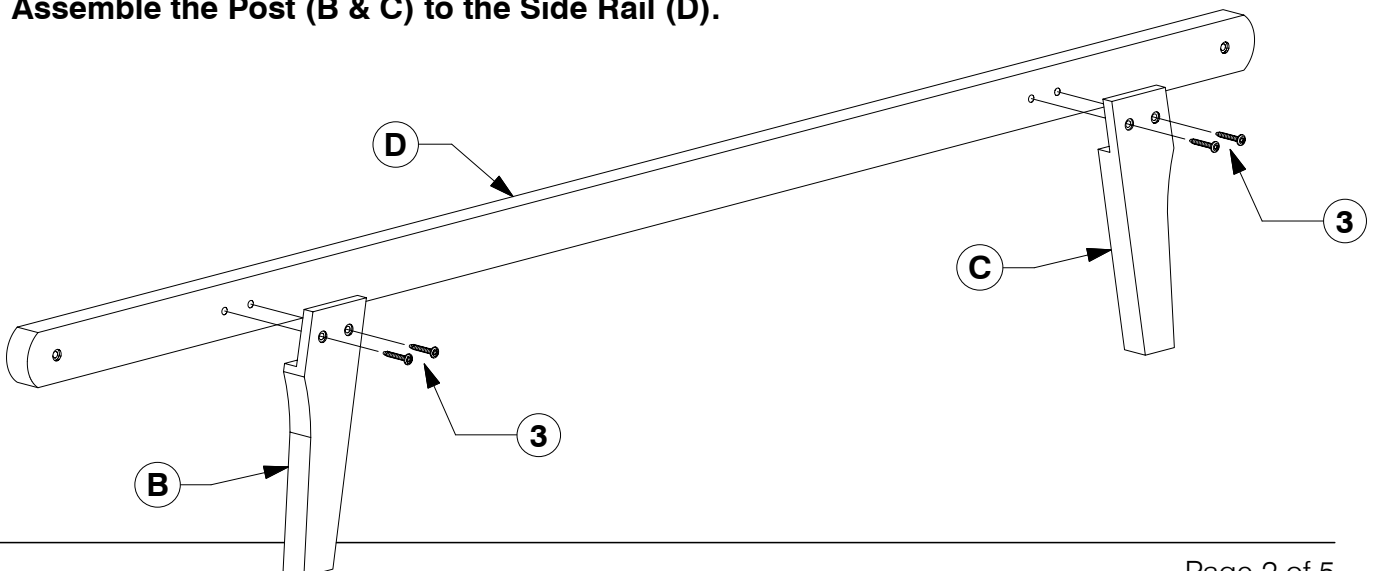

7 Assemble the Side Rail (D) to the Headboard / Footboard Panel (A).

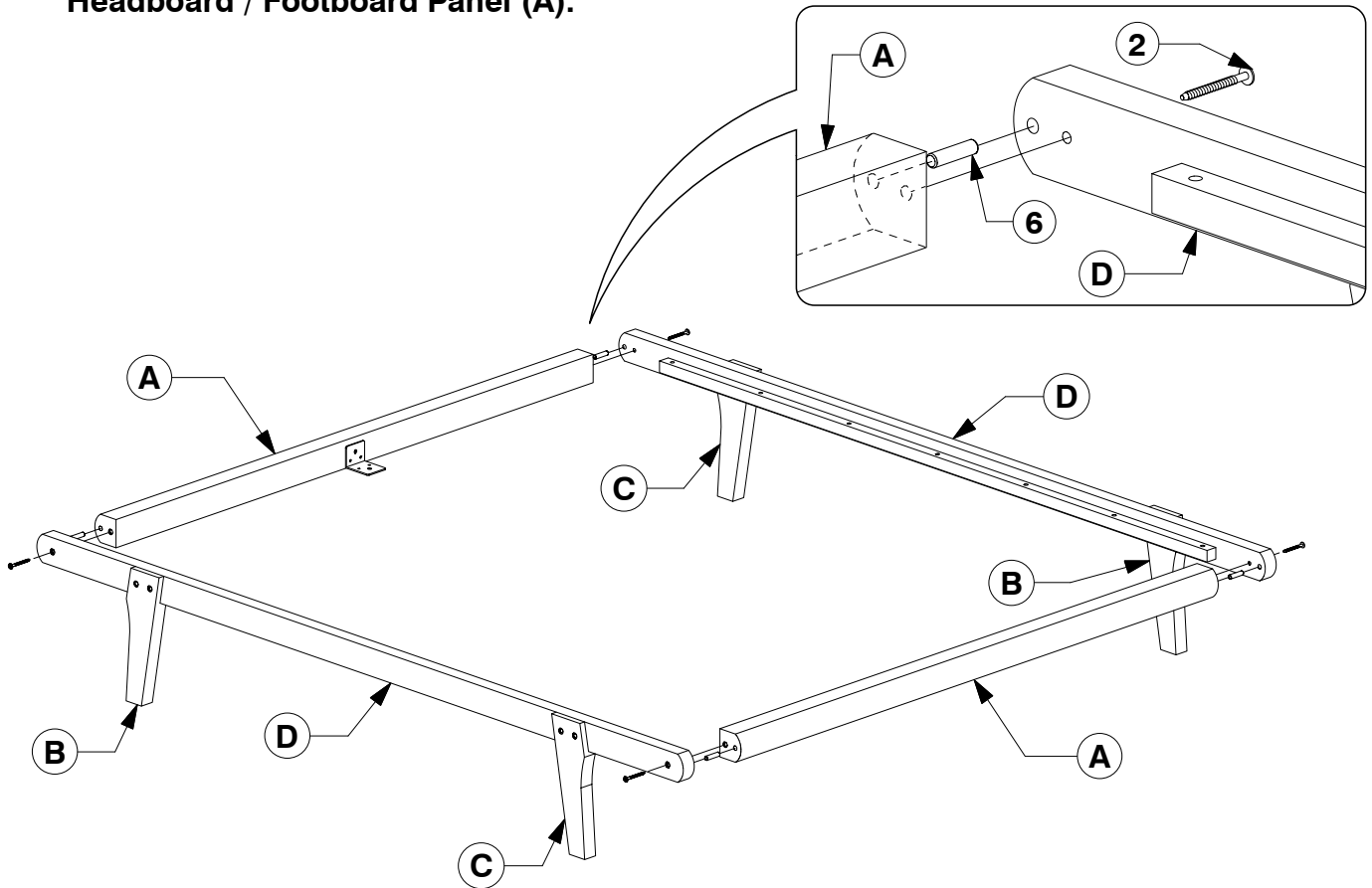

8 Bolt the Long Support (E) to the Center Rail Brackets (8) on the Headboard / Footboard Panel (A).

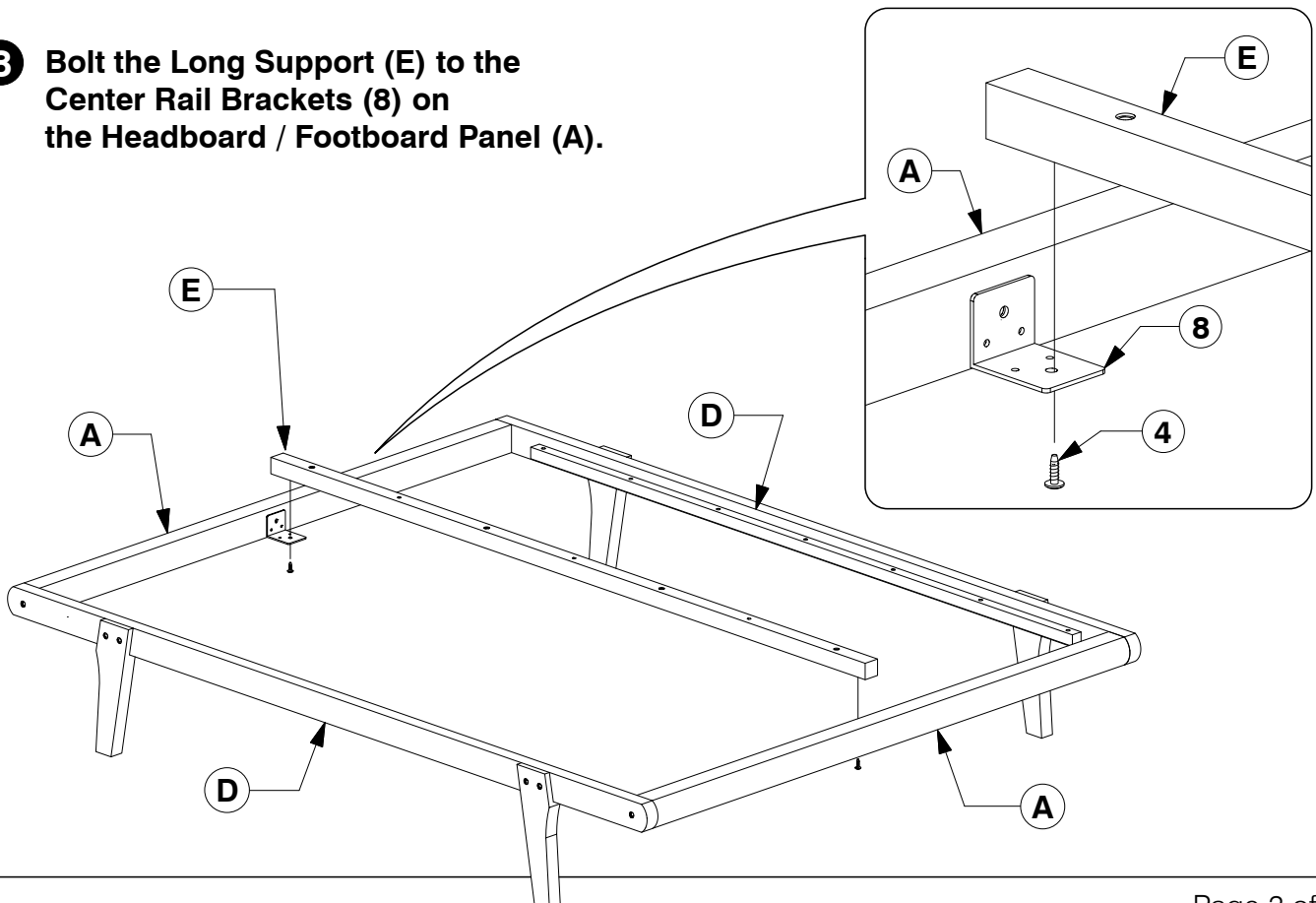

- 9** Fit the first 3 Slats and assemble the Support Leg (F) to the Bed Slat (G). Bolt & screw the Bed Slats (G) to the Side Rail (D) & Long Support (E).

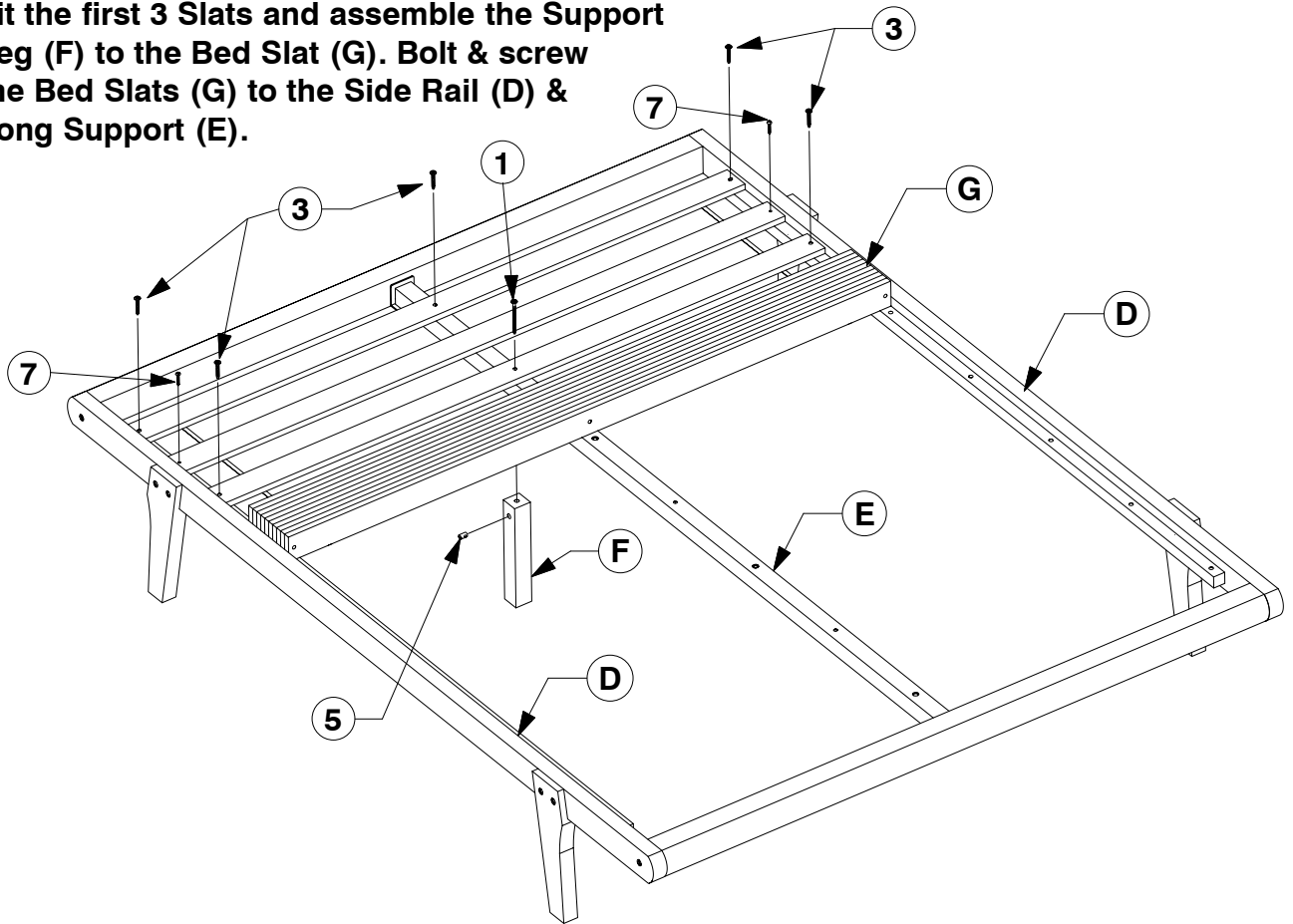

- 10** Fit the other Slats out and assemble the Support Leg (F) to the Bed Slat (G). Bolt & screw the Bed Slats (G) to the Side Rail (D) & Long Support (E).

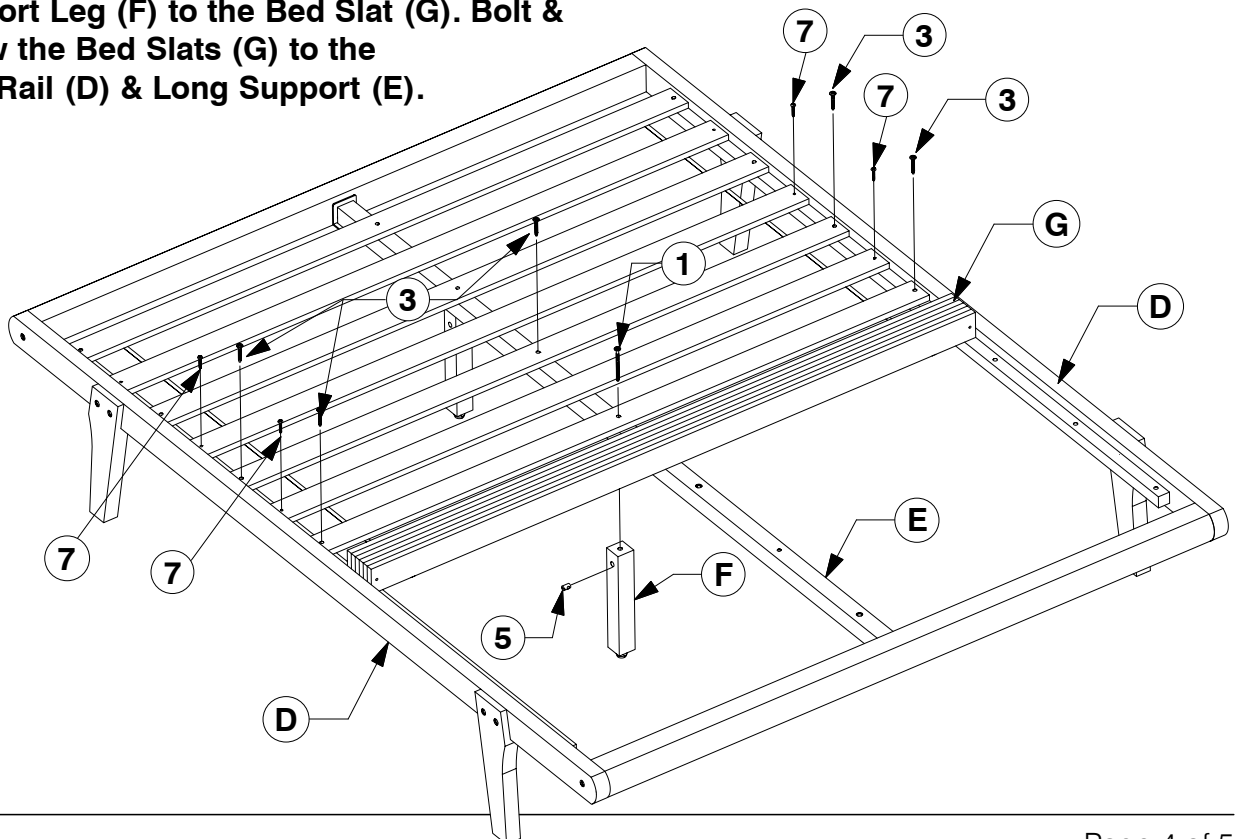

- 11** Fit the other Slats out and assemble the Support Leg (F) to the Bed Slat (G). Bolt & screw the Bed Slats (G) to the Side Rail (D) & Long Support (E).

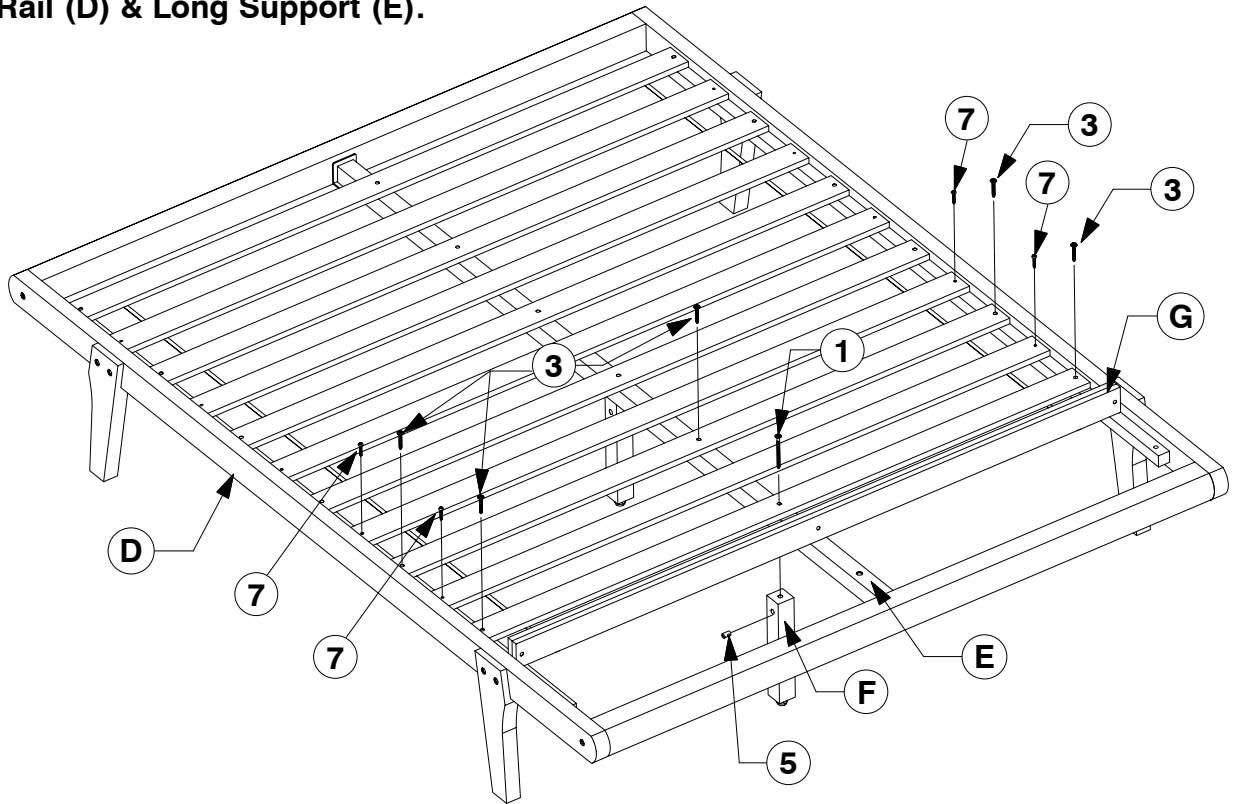

- 12** Bolt & screw the remaining Bed Slats (G) to the Side Rail (D).

