

# ASSEMBLY INSTRUCTION

Step 1: Attach the back side rail (F) and middle panel (E) to arm (A) by pushing the bracket down to fit it. Tighten with Allen Key (1).

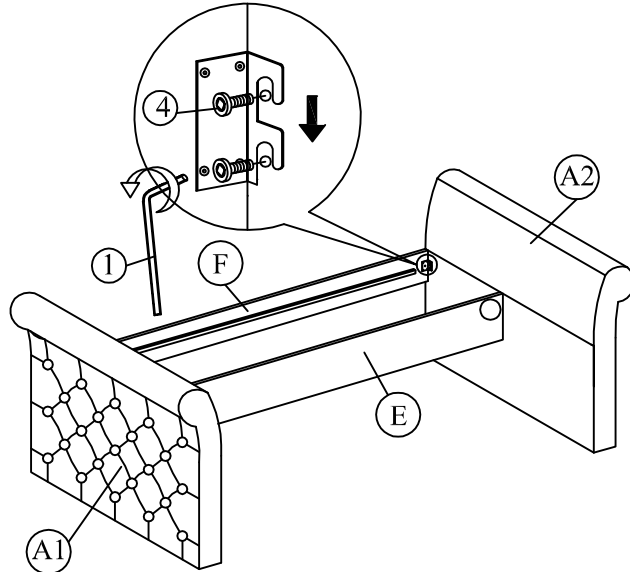

Step 2: Attach the back panel (B) to arm (A). Attach front side rail (D) to arm (A) by pushing the bracket down to fit it. Tighten with Allen Key (1).

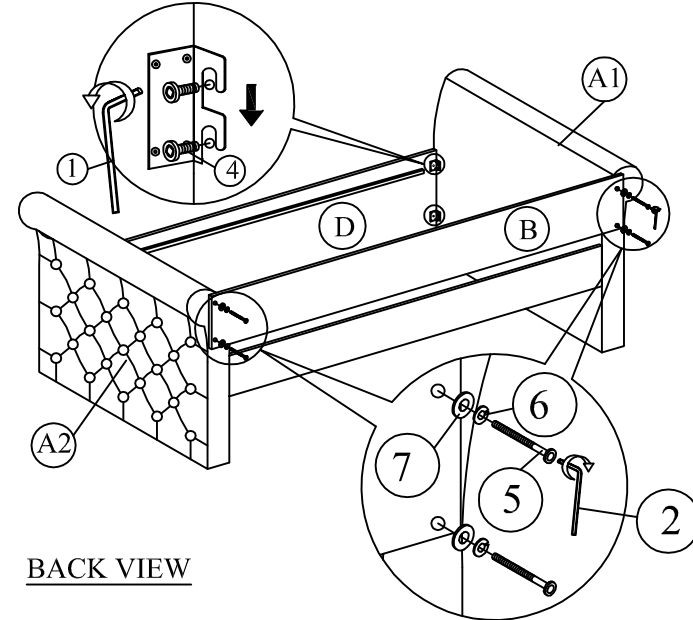

A		1 pc
B		1 pc
C		1 pc
D		1 pc
E		1 pc
F		1 pc

## Packing Hardware

Step 3: Tighten the slats with CSK screw (3). The distance of the slats should be sufficient to obtain desirable bed stability.

1		1 pc
2		1 pc
3		28 pcs
4		16 pcs
5		4 pcs
6		4 pcs
7		4 pcs

