

















ASSEMBLY INSTRUCTION

NO	PART LIST	QTY
1	 BACK REST	1PC
2	 SIDE PANEL (L)	1PC
3	 SIDE PANEL (R)	1PC
4	 FRONT SIDE RAIL	1PC
5	 BACK SIDE RAIL	1PC
6	 LEG	4PCS
7	 SLAT 2 SET	2 SET
8	 SLAT SUPPORT 1PC	1PC
9	 SUPPORT LEG 2PCS	2PCS
ITEM	HARDWARE	QTY
A	 JCBB SCREW M8 x 20MM	12PCS
B	 JCBC SCREW M6 x 50MM	8PCS
C	 SPRING WASHER 4PCS	4PCS
D	 FLAT WASHER 4PCS	4PCS
E	 SCREW M4 x 32MM 14PCS	14PCS
F	 L - KEY M4 x 65MM 1PC	1PC
G	 L - KEY M5 x 65MM 1PC	1PC
H	 STOPPER 2PCS	2PCS

STEP 1

Begin assembly by attaching each Leg (6) to the bottom of the Side Panel (2) & (3) securing with 2 Allen Bolt (B) per panel using L-key (F). Then attach the Front Rail (4) and Back Rail (5) to the Side Panel (2) & (3) aligning holes and securing with 2 Allen Bolts (A) per each end using L-key (G).
(DO NOT FULLY TIGHTEN BOLTS FOR THIS STEP)

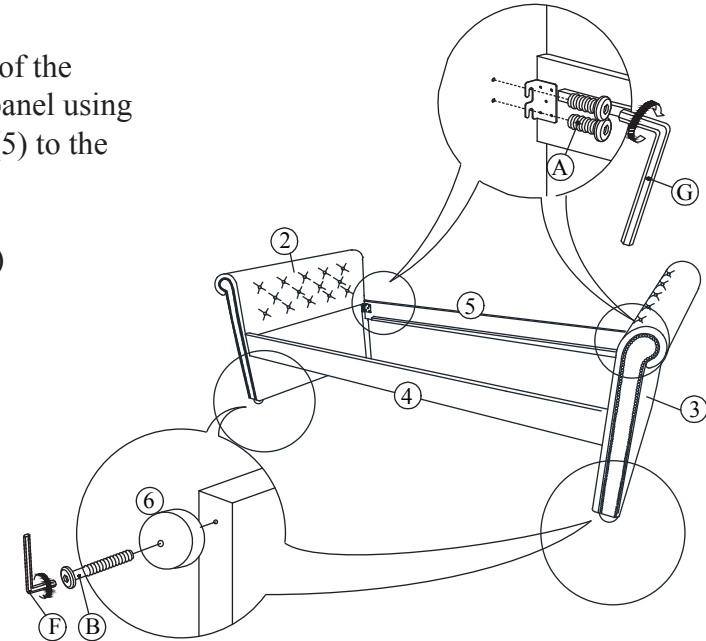

STEP 2

Attach the Back Rest (1) to the back of each Side Panel (2) & (3) by aligning the hole and securing with 2 Allen Bolts (B), 2 Spring Washer (C), 2 Flat Washer (D) from the back side per each end using L-key (F).
(DO NOT FULLY TIGHTEN BOLTS FOR THIS STEP)

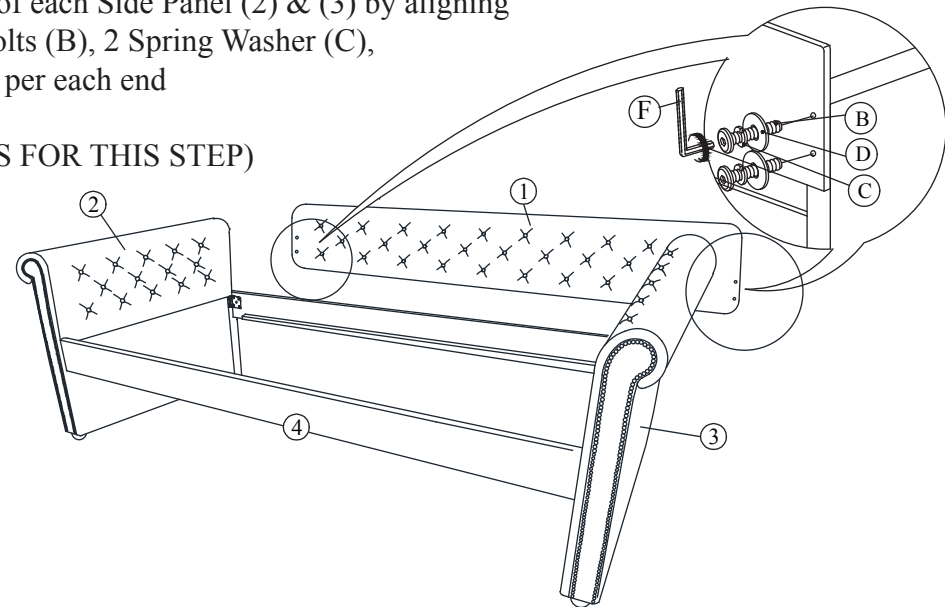

Please do not tighten the hardware until the entire assembly is completed.

ASSEMBLY INSTRUCTION

STEP 3

Secure 2 Support Leg (9) to the Slat Support (8) as shown on step 3.1. Insert the pre-set metal on Slat Support (8) to the metal bracket on each side of Side Panel (2) & (3). Then securing the metal bracket as shown in step 3.3 with 1 Screw (E) each side using Phillips Head Screwdriver (NOT INCLUDED)

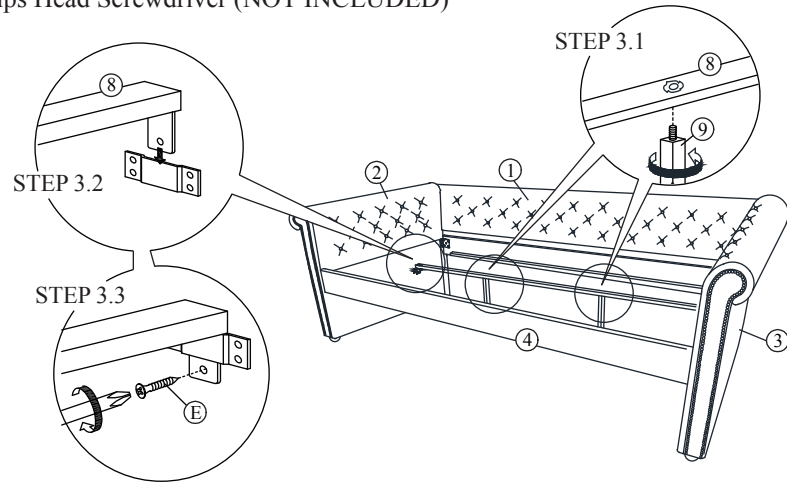

STEP 5

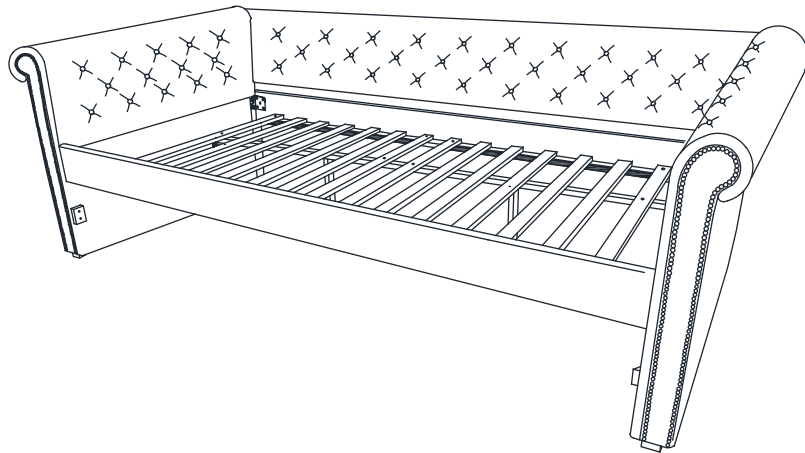

ASSEMBLY
COMPLETE

STEP 4

Tighten All Bolts from step 1 to step 3 by using L-key (F) & (G) that has been provided. Attached Slat (7) to Front Side Rail (4) & Back Side Rail (5) by unrolling and securing with 6 Screw (E), per set using Phillips Head Screwdriver. Securing Slat (7) to Back Side Rail (5) with 2 Screw (E) per each side as step 4.1. Following by step 4.2, using 1 Screw (E) to secure Slat (7) to Front Side Rail (4). Repeat the same step to attach another set of Slat (7).

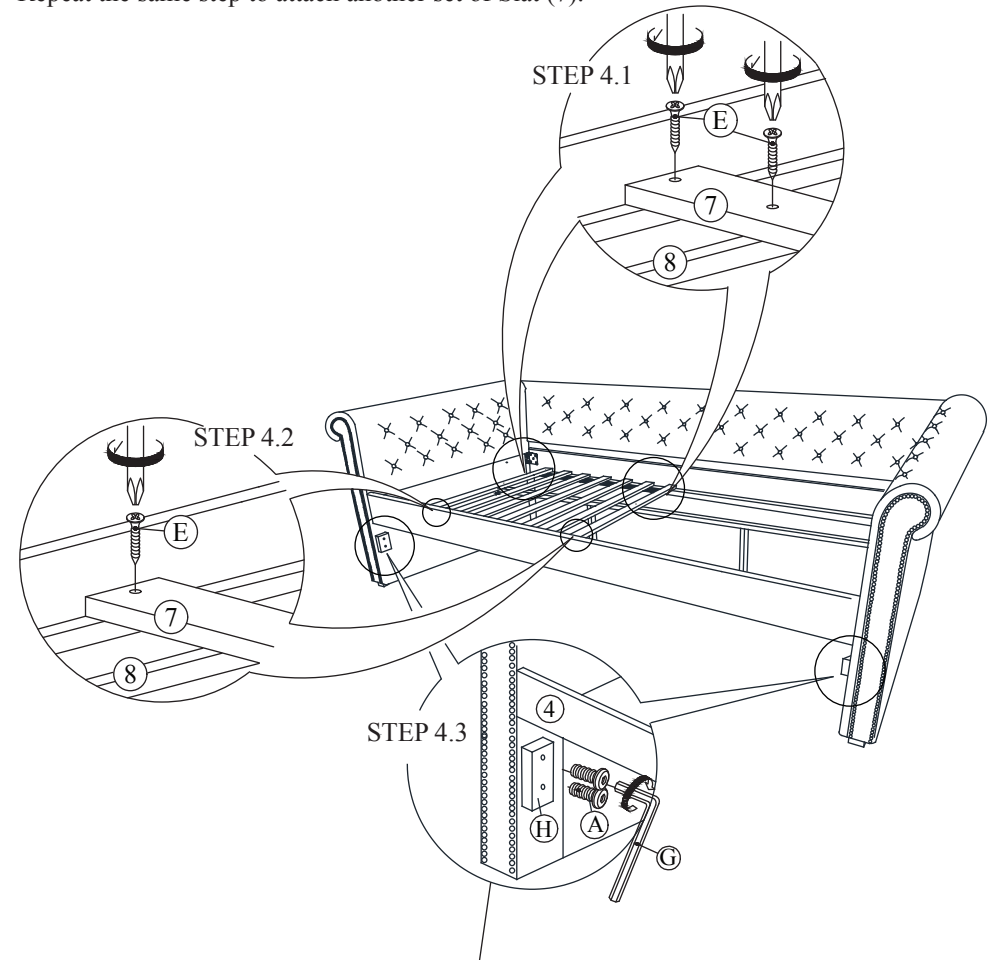

Step 4.3 attach the Stopper (H) to the front side of Side Panel (2) & (3) each side by securing with 2 Allen Bolt (A) using L-key (G) to avoid trundle pull out.

Please do not tighten the hardware until the entire assembly is completed.

ASSEMBLY INSTRUCTION

NO	PART LIST	QTY
1	TRUNDLE FRONT RAIL	1PC
2	TRUNDLE BACK RAIL	1PC
3	TRUNDLE SIDE RAIL	2PCS
4	SLAT	2 SET
5	SLAT SUPPORT	3PCS
6	CASTOR	6PCS
ITEM	HARDWARE	QTY
A	JCBB SCREW M8 x 20MM	8PCS
B	JCBC SCREW M6 x 50MM	12PCS
C	SPRING WASHER	12PCS
D	FLAT WASHER (Small)	12PCS
E	SCREW M4 x 16MM	24PCS
F	SCREW M4 x 32MM	8PCS
G	L - KEY M4 x 65MM	1PC
H	L - KEY M5 x 65MM	1PC

STEP 1

Begin with attaching Trundle Side Rail (3) to Front Rail (1) & Back Rail (2) using 2 Bolts (A) per corner. Tighten bolts with Allen Key (H) provided.

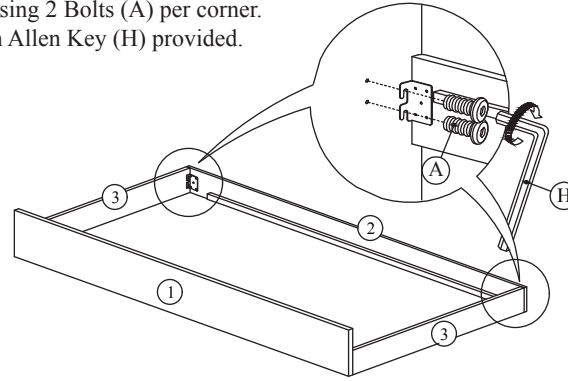

STEP 3

Attach Slat Support (5) to Front Rail (1) & Back Rail (2) using 2 Bolts (B), 2 Spring Washers (C) and 2 Flat Washer (D) on each end of each Slat Support (5). Tighten bolts with Allen Key (G).

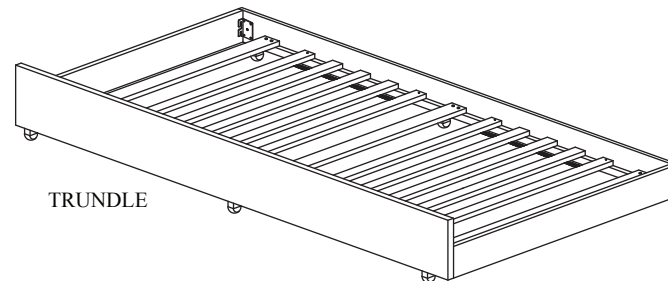
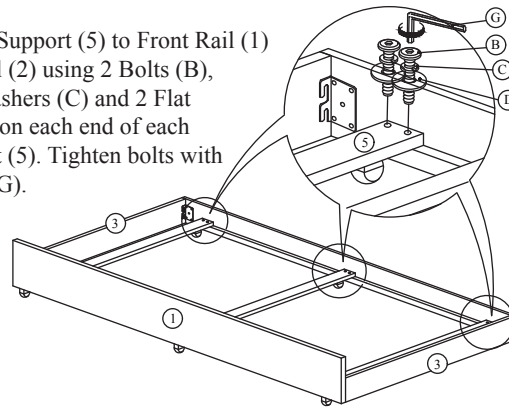

STEP 2

Assembly by tracing around the Castors (6) onto the Slats Support (5). Secure Castors (6) to Slats Support (5) using 4 Screws (E) per castor. Tighten screws with Phillips screwdriver (not included)

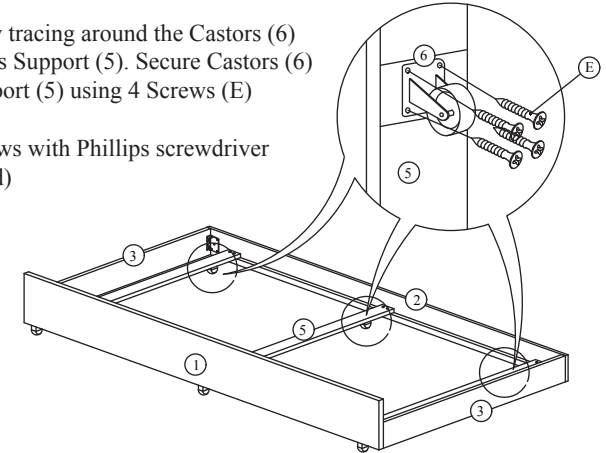

STEP 4

Attach Slat (4) to Front Rail (1) & Back Rail (2) using 4 Screws (F) per set. Tighten screws with Phillips screwdriver (not included)

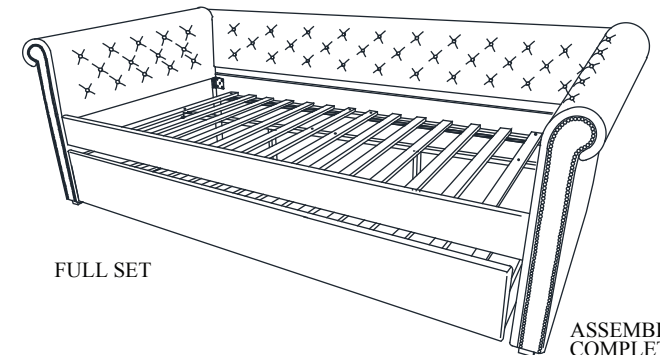
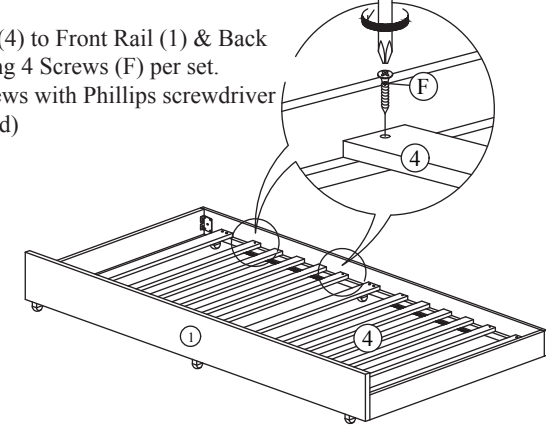

Please do not tighten the hardware until the entire assembly is completed.