

Various utilization

Please check below samples for various utilization.

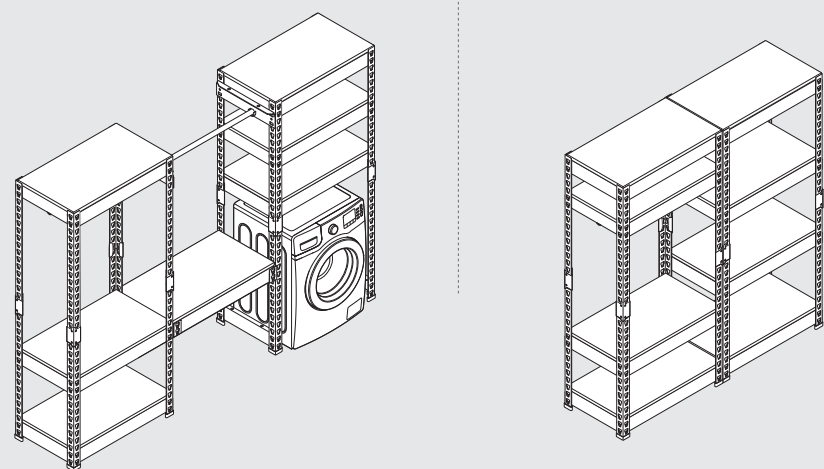
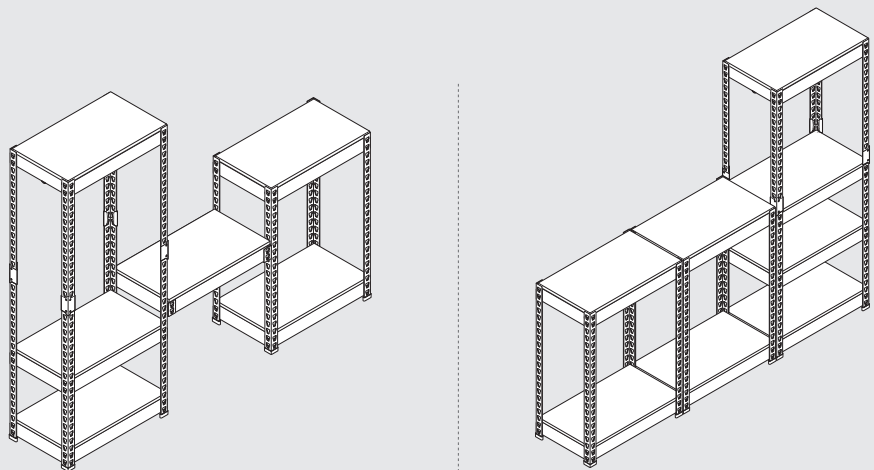

BASIC INSTRUCTION

Step 1I

PLEASE INSERTING SAFETY CAP TO THE PILLAR FOR PROTECTING GROUND

* MAKE SURE SMALL SQUARE MUST BE DOWNSIDE OF THE PILLAR

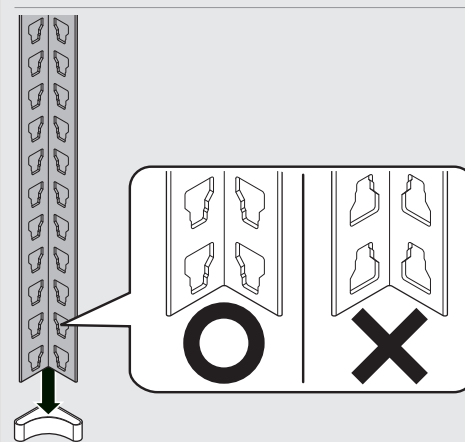

Step 2I

PUT SHORT SUPPORT RIM BETWEEN TOW PILLARS BY USING RUBBER HAMMER

* THE SURFACE OF SUPPORT RIM WILL HOLD THE BOARD

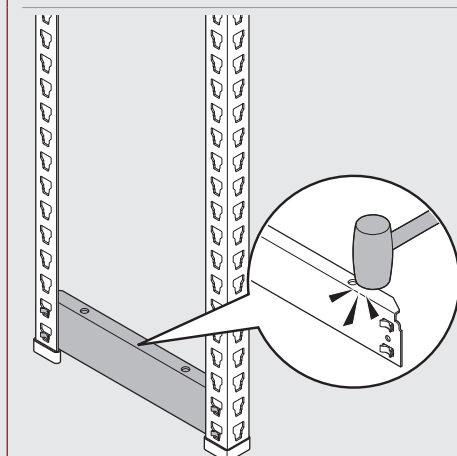

Step 3I

CONNECT THE UPPER PILLAR WITH THE LOWER PILLAR BY USING BRACKET

* MAKE SURE SMALL SQUARE MUST BE DOWNSIDE OF THE PILLAR

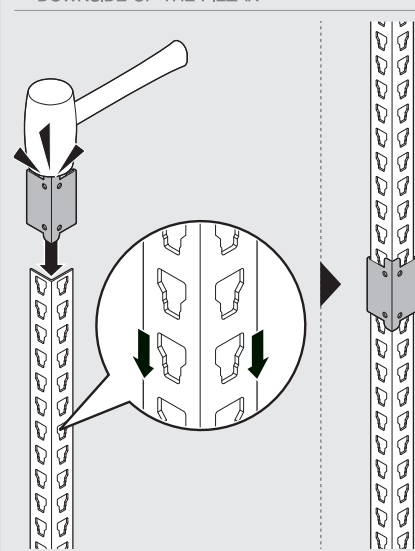

Tip

HOW TO DISJOINT BRACKET

PULL OUT THE UPPER PILLAR FROM THE BRACKET. IF THE BRACKET STILL STICKED ON THE PILLAR, PLEASE USE SUPPORT RIM AS A MALLET.

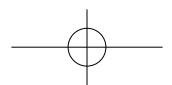
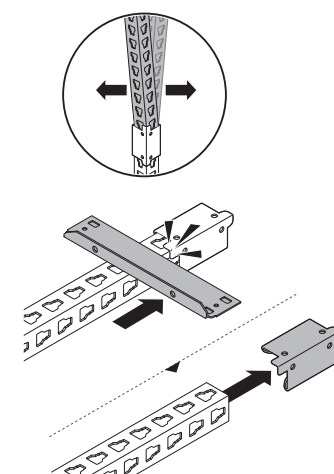

ASSEMBLING GUIDE

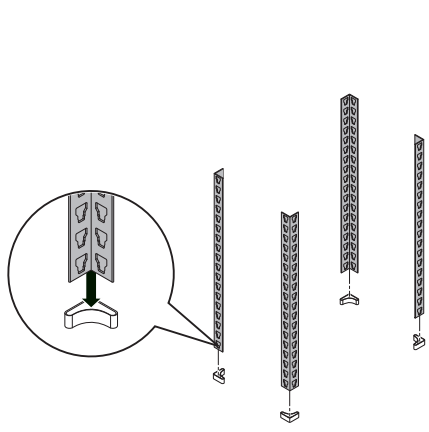

1 INSERTING SAFETY CAP INTO THE PILLAR

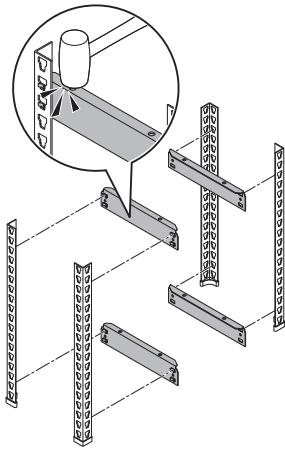

2 ASSEMBLING SHORT SUPPORT RIM AT FIRST AND SECOND TIER

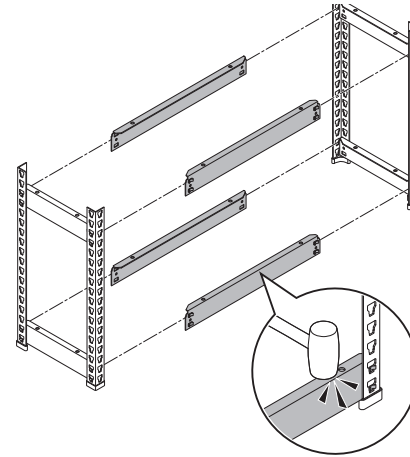

3 ASSEMBLING LONG SHORT SUPPORT RIM AT FIRST AND SECOND TIER

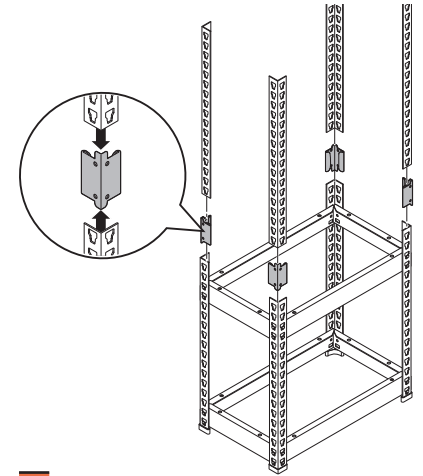

4 CONNECT THE UPPER PILLAR WITH THE LOWER PILLAR BY USING BRACKET

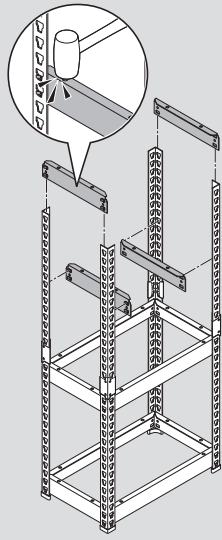

5 ASSEMBLING SHORT SUPPORT RIM AT THIRD AND FOURTH TIER

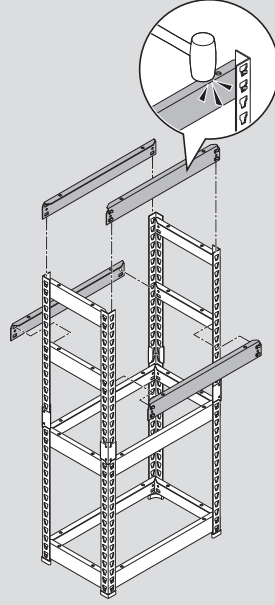

6 ASSEMBLING LONG SUPPORT RIM AT THIRD AND FOURTH TIER

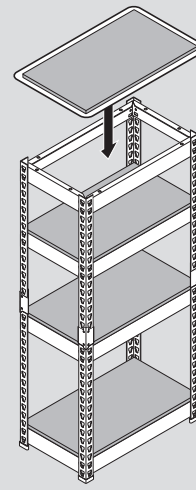

7 PUT WOODEN BOARD AT THE FRAME

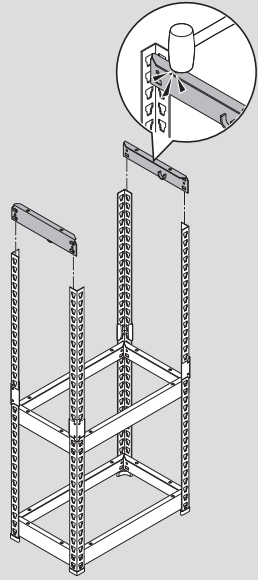

5 ASSEMBLING HANGER SUPPORT RIM AT THIRD TIER

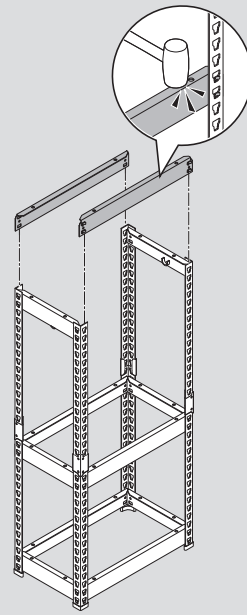

6 ASSEMBLING LONG SUPPORT RIM AT THIRD TIER

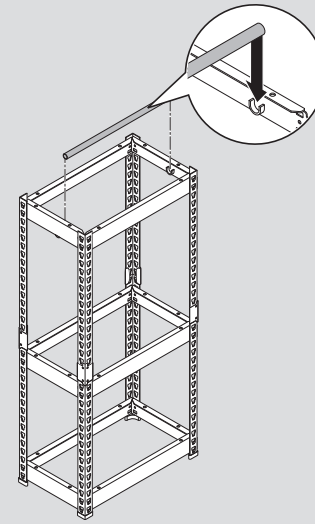

7 PUT HANGER PIPE JUST INTO THE HOLE OF HANGER SUPPORT RIM

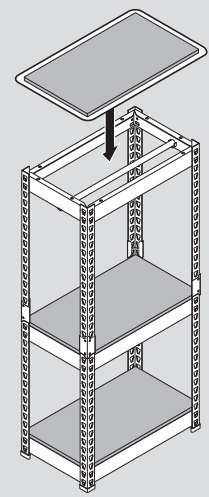

8 PUT WOODEN BOARD AT THE FRAME