

ASSEMBLY INSTRUCTION

MODEL : 8233 / TV CABINET

Before you begin, please follow assembly instruction carefully.
Then follow them step by step.

STEP 1

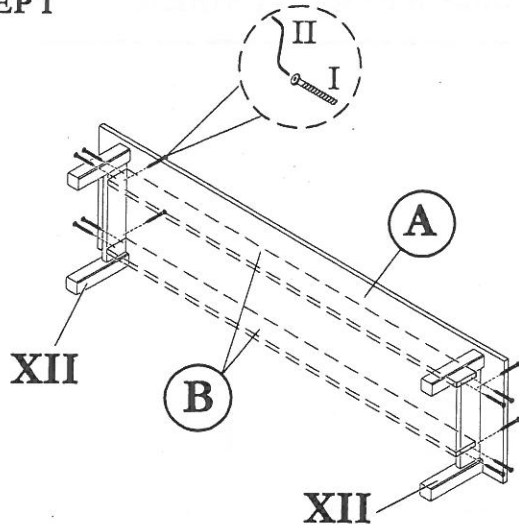

STEP 2

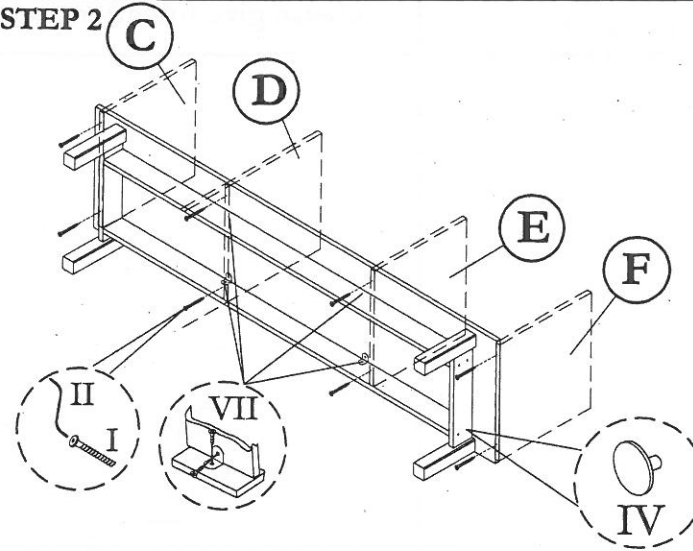

STEP 3

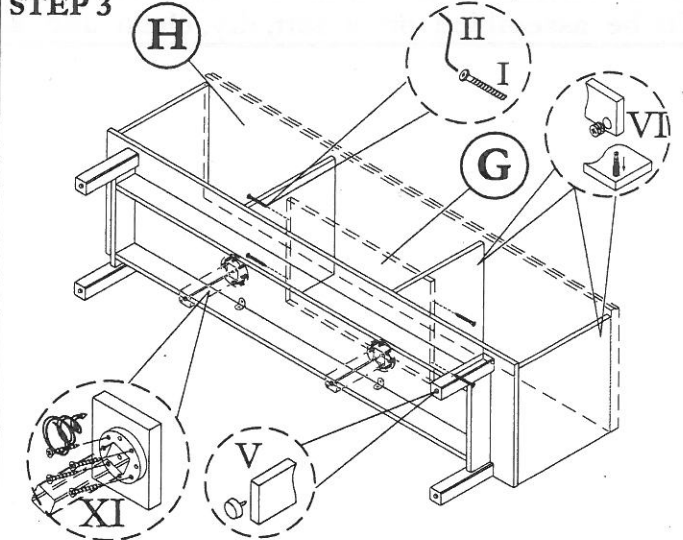

STEP 4

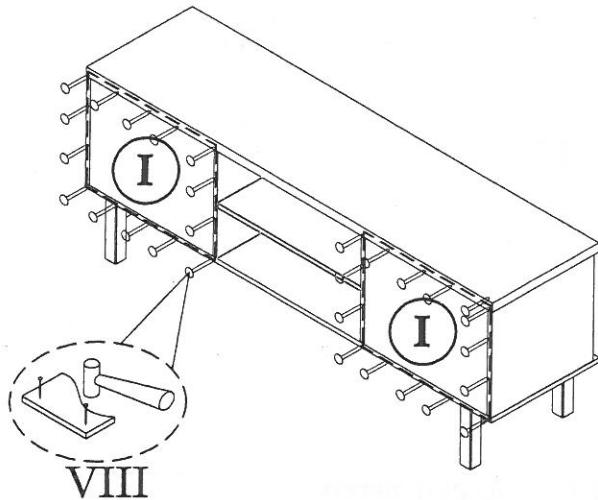

STEP 5

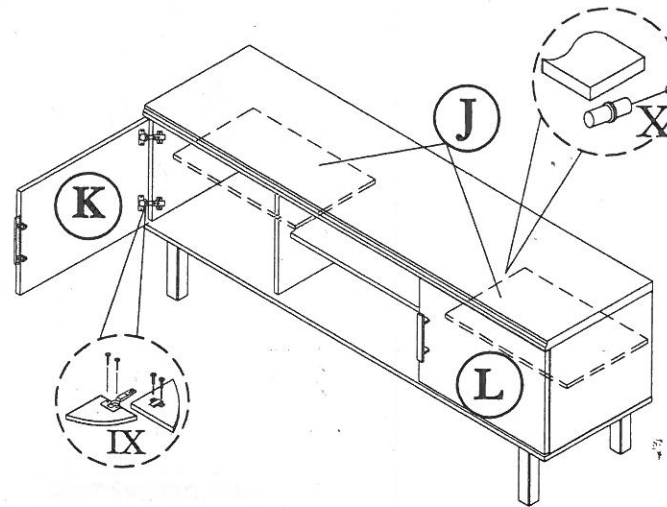

STEP 6

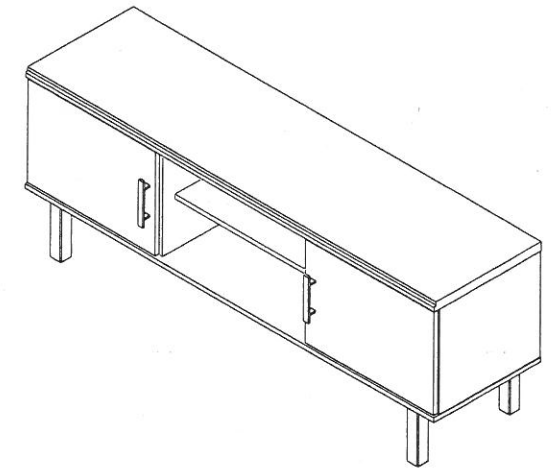

HARDWARE LIST

NO	DESCRIPTION	QTY
I	JCBCW SCREW M6 x 45	24pcs
II	M4 ALLEN KEY	1pc
III	HANDLE & SCREW M3.5 x 30	2sets
IV	CAP SMALL	8pcs

V	PVC NAIL WITH PIN	6pcs
VI	Q-FIT	8sets
VII	L BRACKET & SCREW M3.5 x 12	4sets
VIII	NAIL	50pcs
IX	HINGES (A) & SCREW M3.5 x 16	4sets
X	SHELF SUPPORT	8pcs

XI	WOOD LEG, SUPPORT & SCREW M3.5 x 20	2sets
XII	WOOD LEG SIZE : 14 7/8 "	2pcs

CAUTION:

To clean use soft, dry cloth. Do not use detergent or chemicals
 Avoid contact with water and direct sunlight.
 To be assembled on a soft, dry, clean and smooth surface.

ORDERING REPAIR PARTS

In order to obtain smooth and rapid service when ordering repair parts,
 please give full attention to the following of PART NUMBER.

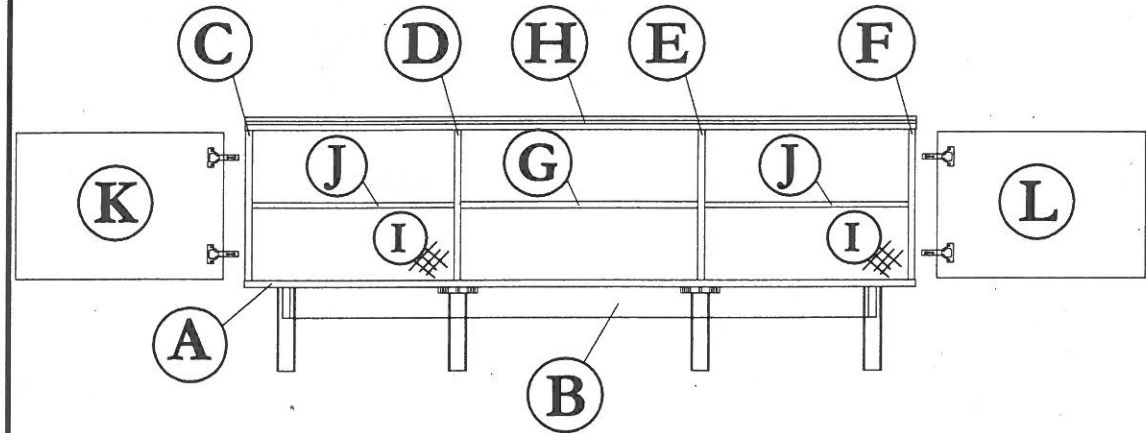
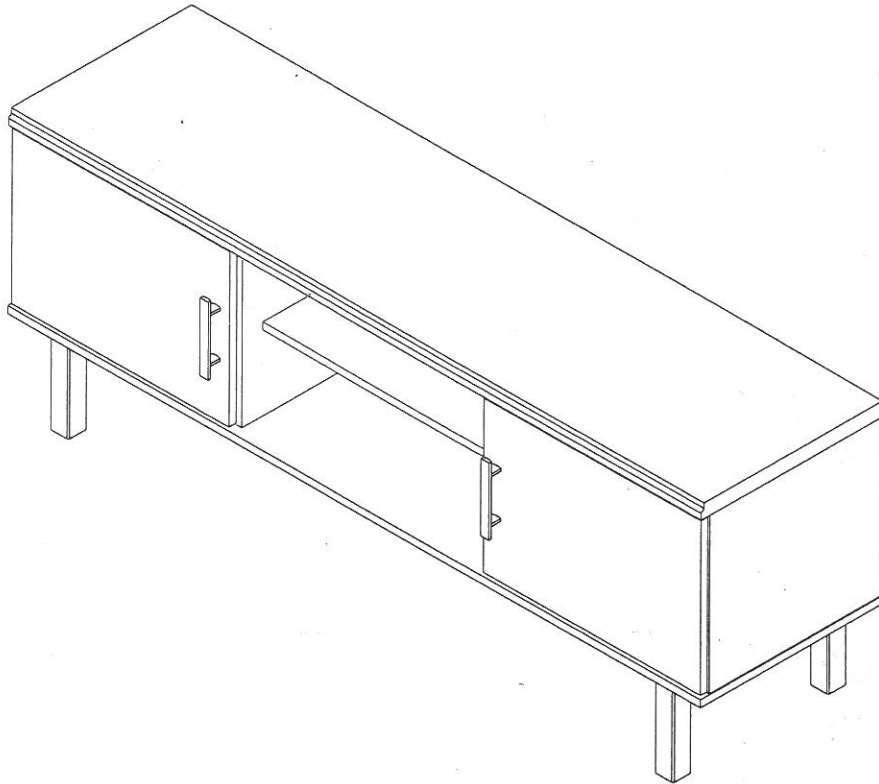

COMPLETE SET

NO	DESCRIPTION	QTY
A	LOWER SHELF	01
B	LEG	02
C	LEFT SIDE	01
D	CENTRE VERTICAL	01
E	CENTRE VERTICAL	01
F	RIGHT SIDE	01

NO	DESCRIPTION	QTY
G	CENTRE SHELF	01
H	TOP	01
I	BACK (Left / Right)	02
J	MOVABLE SHELF	02
K	LEFT SIDE DOOR	01
L	RIGHT SIDE DOOR	01