









ASSEMBLY INSTRUCTION

NO	PARTLIST	QTY
1	 CHAIR BACK	1 PC
2	 CUSHION SEAT	1 PC
3	 LEG	2 PCS

NO	HARDWARE LIST	QTY
A	 JCBC SCREWS M6 X 40mm	2 PCS
B	 JCBC SCREWS M6 X 60mm	4 PCS
C	 JCBC SCREWS M6 X 80mm	4 PCS
D	 SPRING WASHERS	10 PCS
E	 FLAT WASHERS	10 PCS
F	 L KEY M4 X 65mm	1 PC

STEP 1

Insert leg (3) into cushion seat (2) as picture shown. Aligning the hole and securing with 1 Allen Bolt (B) , 1 spring washer (D) , 1 flat washer (E) by using L-key (F) per leg. Repeat the same step for the second leg installation.

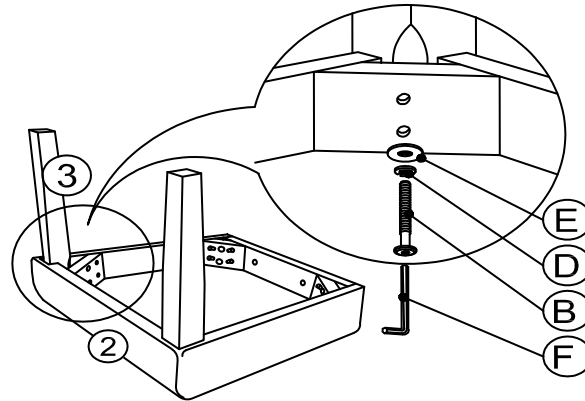

STEP 2

Put the cushion seat (2) onto the chair back (1) as picture shown. Aligning the holes & securing with 1 Allen Bolt (A) , 1 spring washer (D) , 1 flat washer (E) by using L-key (F) each holes.

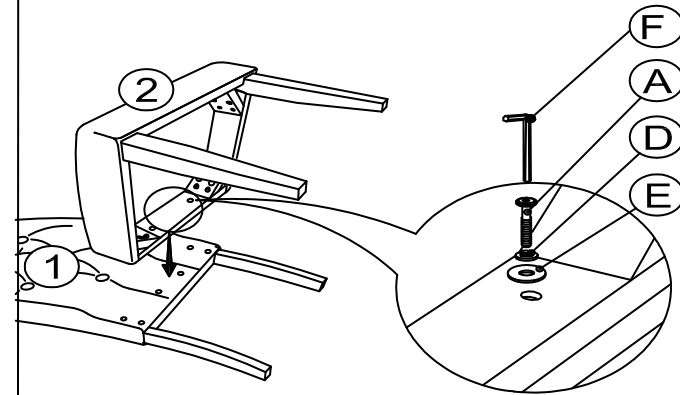

STEP 3

Securing each corner where the cushion seat is connected to the chair back by using 2 Allen Bolts (C) , 2 spring washer (D) , 2 flat washer (E) and L-key (F).

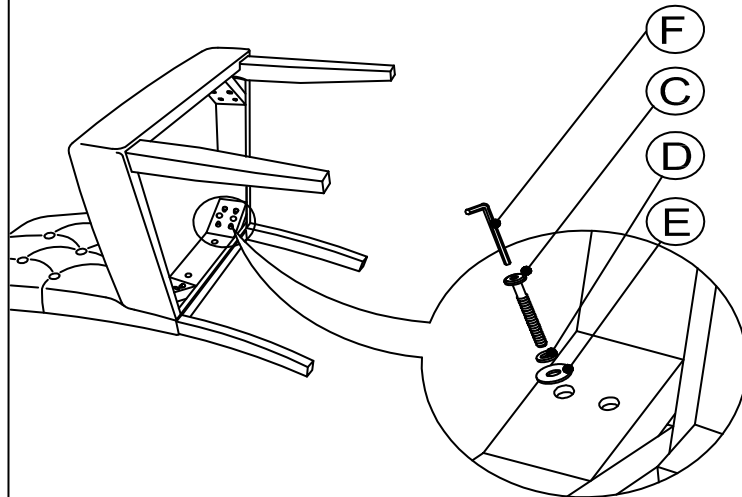

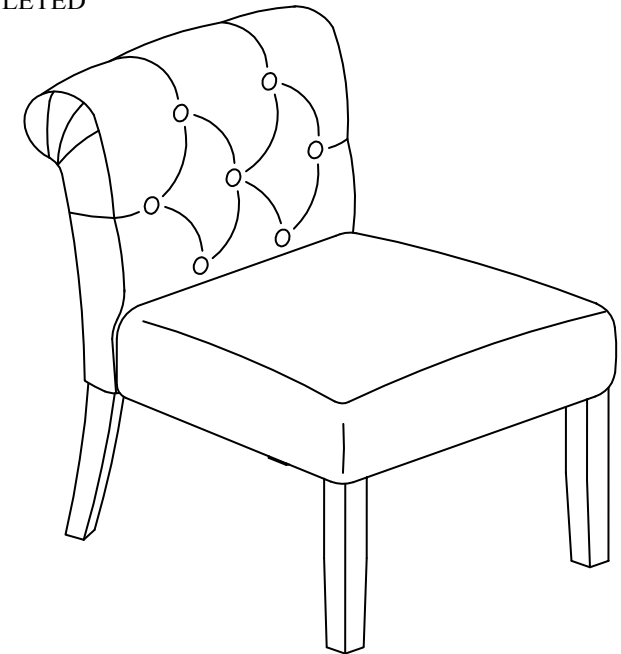

ASSEMBLY COMPLETED





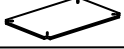

IMPORTANT NOTICE :

THE ABOVE PART LIST , HARDWARE & ASSEMBLY STEP IS FOR 1 PC ACCENT CHAIR ONLY. PLEASE REPEAT THE SAME STEP FOR THE ANOTHER ONE ACCENT CHAIR.

ASSEMBLY INSTRUCTION

NO	PARTLIST	QTY
1	 TABLE TOP 1 PC	1 PC
2	 SHELF 1 PC	1 PC
3	 LEG 4 PCS	4 PCS

NO	HARDWARE LIST	QTY
A	 JCBC SCREWS M6 X 50mm 8 PCS	8 PCS
B	 SPRING WASHERS 8 PCS	8 PCS
C	 FLAT WASHERS 8 PCS	8 PCS
D	 SCREW M4 x 32MM 4 PCS	4 PCS
E	 L KEY M4 X 65mm 1 PC	1 PC

STEP 1

Insert the legs (3) to the table top (1) as picture shown. Aligning the hole and securing with 2 Allen Bolt (A) , 2 Spring Washer (B) , 2 Flat Washer (C) per each corner of the table by using L-Key (E) . Ensuring the notched part of legs are inserting as below picture shown.

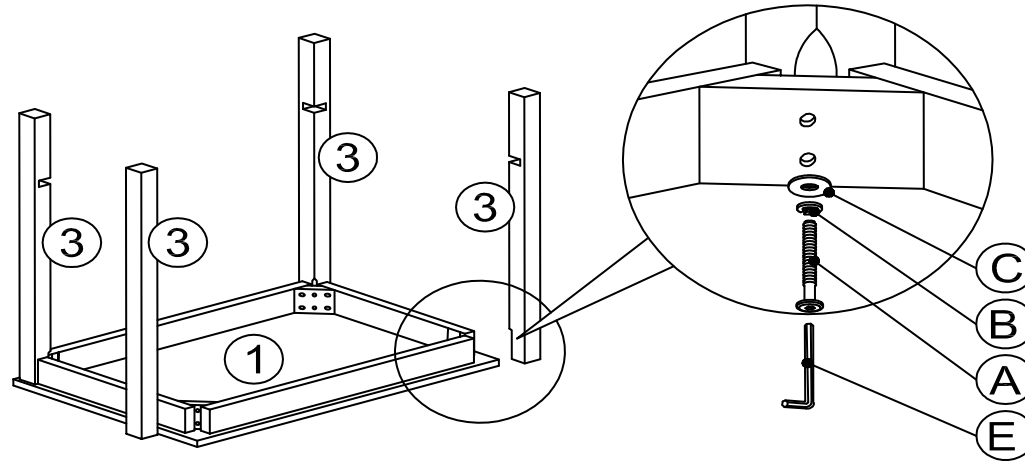

STEP 2

Place the shelf (2) into the notched part of legs (3) by securing the pre-drilled holes with 1 clipboard screw (D) per each corner using philips Head Screwdriver (NOT INCLUDED)

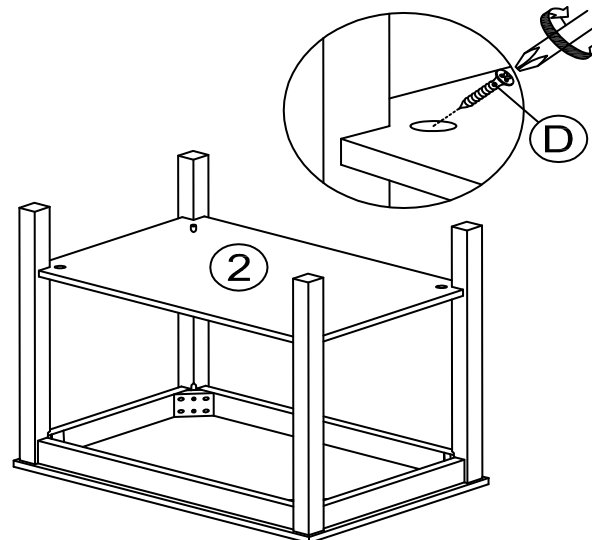

COMPLETED

