









ASSEMBLY INSTRUCTION

NO	PARTLIST	QTY
1	 CHAIR BACK	1 PC
2	 CUSHION SEAT	1 PC
3	 LEG	2 PCS

NO	HARDWARE LIST	QTY
A	 JCBC SCREWS M6 X 40mm	2 PCS
B	 JCBC SCREWS M6 X 60mm	4 PCS
C	 JCBC SCREWS M6 X 80mm	4 PCS
D	 SPRING WASHERS	10 PCS
E	 FLAT WASHERS	10 PCS
F	 L KEY M4 X 65mm	1 PC

STEP 1

Insert leg (3) into cushion seat (2) as picture shown. Aligning the hole and securing with 1 Allen Bolt (B) , 1 spring washer (D) , 1 flat washer (E) by using L-key (F) per leg. Repeat the same step for the second leg installation.

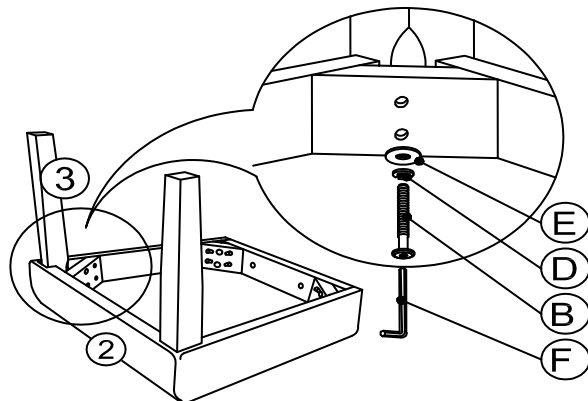

STEP 2

Put the cushion seat (2) onto the chair back (1) as picture shown. Aligning the holes & securing with 1 Allen Bolt (A) , 1 spring washer (D) , 1 flat washer (E) by using L-key (F) each holes.

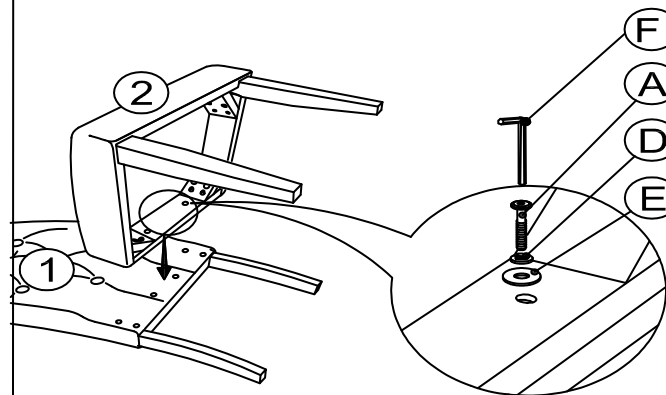

STEP 3

Securing each corner where the cushion seat is connected to the chair back by using 2 Allen Bolts (C) , 2 spring washer (D) , 2 flat washer (E) and L-key (F).

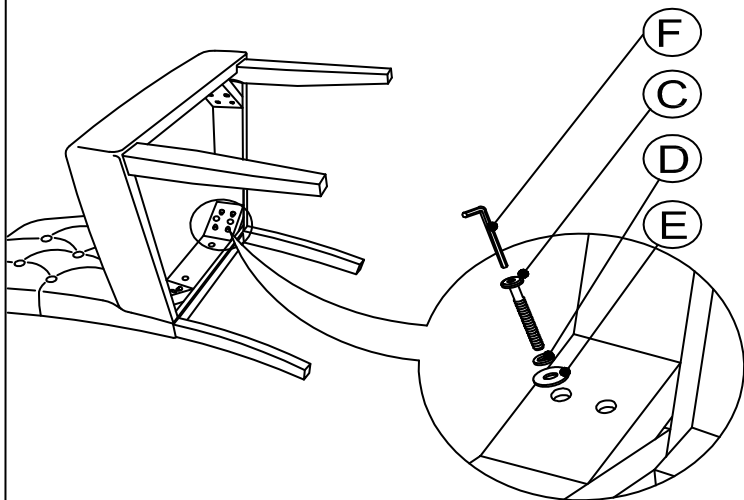

ASSEMBLY COMPLETED

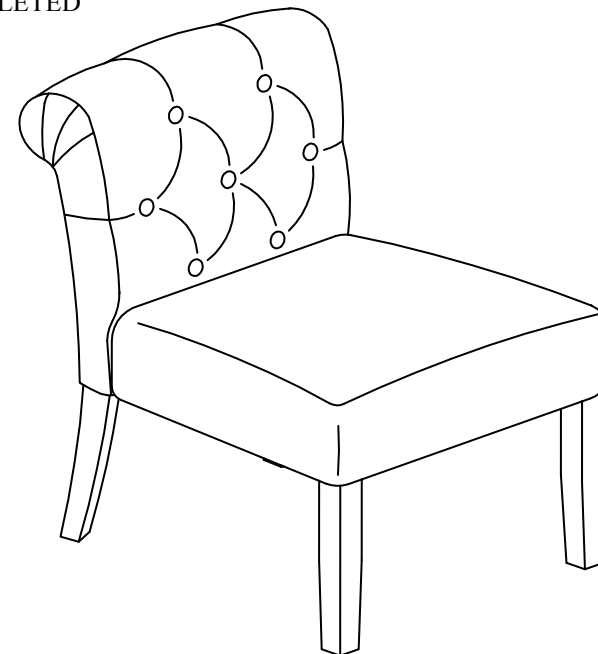

IMPORTANT NOTICE :

THE ABOVE PART LIST , HARDWARE & ASSEMBLY STEP IS FOR 1 PC ACCENT CHAIR ONLY. PLEASE REPEAT THE SAME STEP FOR THE ANOTHER ONE ACCENT CHAIR.