

ASSEMBLY INSTRUCTIONS

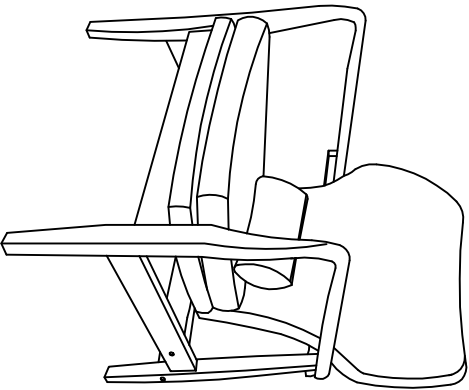

ASSEMBLY TIPS

1. Remove hardware from box and sort by size.
2. Please check to see that all hardware and parts are present prior start of assembly.
3. Please follow attached instructions in the same sequence as as numbered to assure fast and easy assembly.
4. Estimated 45 minutes required for assembly.



1. Don't attempt to repair or modify parts that are broken or defective. Please contact the store immediately.
2. This product is for home use only and not intended for commercial establishments.



2 PEOPLE REQUIRED

HARDWARE LIST

1	10 PCS	5	13 PCS
JCBC	M6 x 40mm		WOOD DOWEL Ø10 x 30mm
2	6 PCS	6	4 PCS
JCBC	M6 x 50mm		WOODEN CAP
3	3 PCS	7	1 PC
JCBC	M6 x 80mm		ALLEN KEY (M4)
4	4 PCS		
	WOOD SCREW 4.0 x 32mm		

COMPONENT LIST

A	1 SET	F	1 PC
			BACK RAIL (LOWER)
B	1 SET	G	1 PC
			BACK RAIL SUPPORT (LEFT)
C	1 PC	H	1 PC
			BACK RAIL SUPPORT (RIGHT)
D	1 PC	J	1 PC
			SEAT DECK
E	1 PC	K	2 PCS
			BACK REST
			CUSHION
			LARGE 1 PC
			SMALL 1 PC

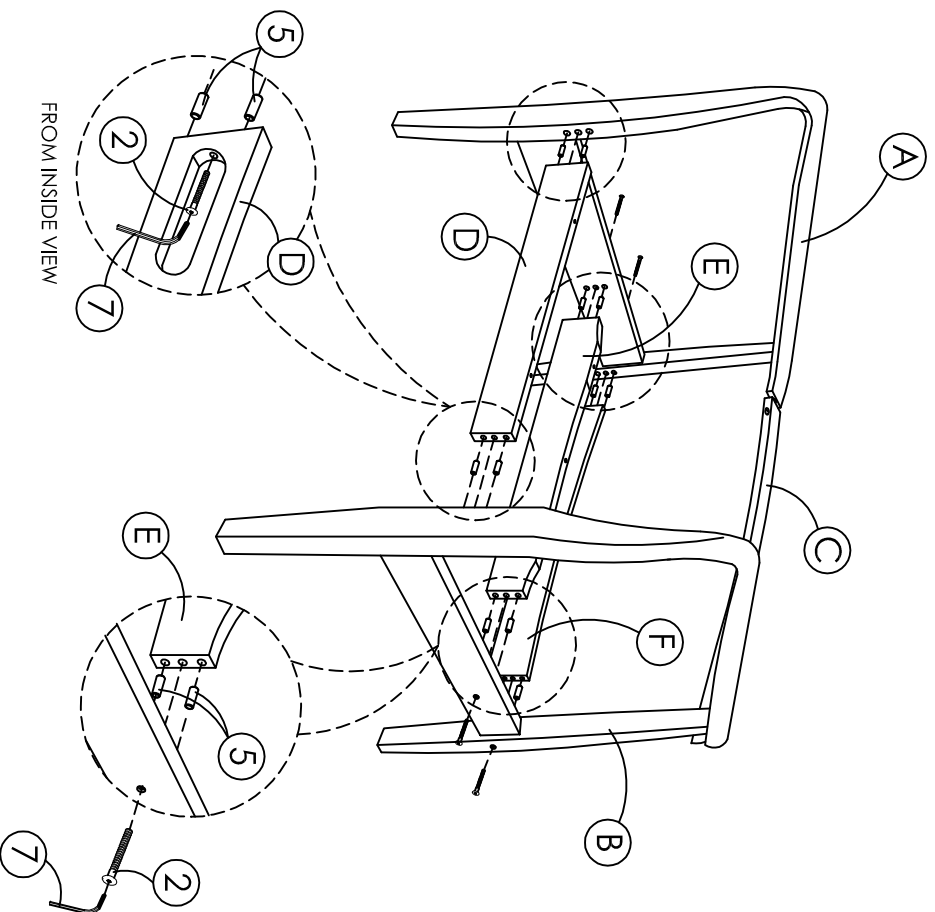

1. Fix arm chair left & right (A & B) to front rail (D), center rail (E) and back rail lower (F) with WOOD DOWEL (5) and JCBC BOLT (2). Do not fully tighten.
2. Please make sure center rail (E) in correct position with "BACK" sticker facing backward.
3. Please make sure back rail (F) in correct position with curve shape facing downward.
4. Then slot upper back rail (C) to arm chair left & right (A & B).

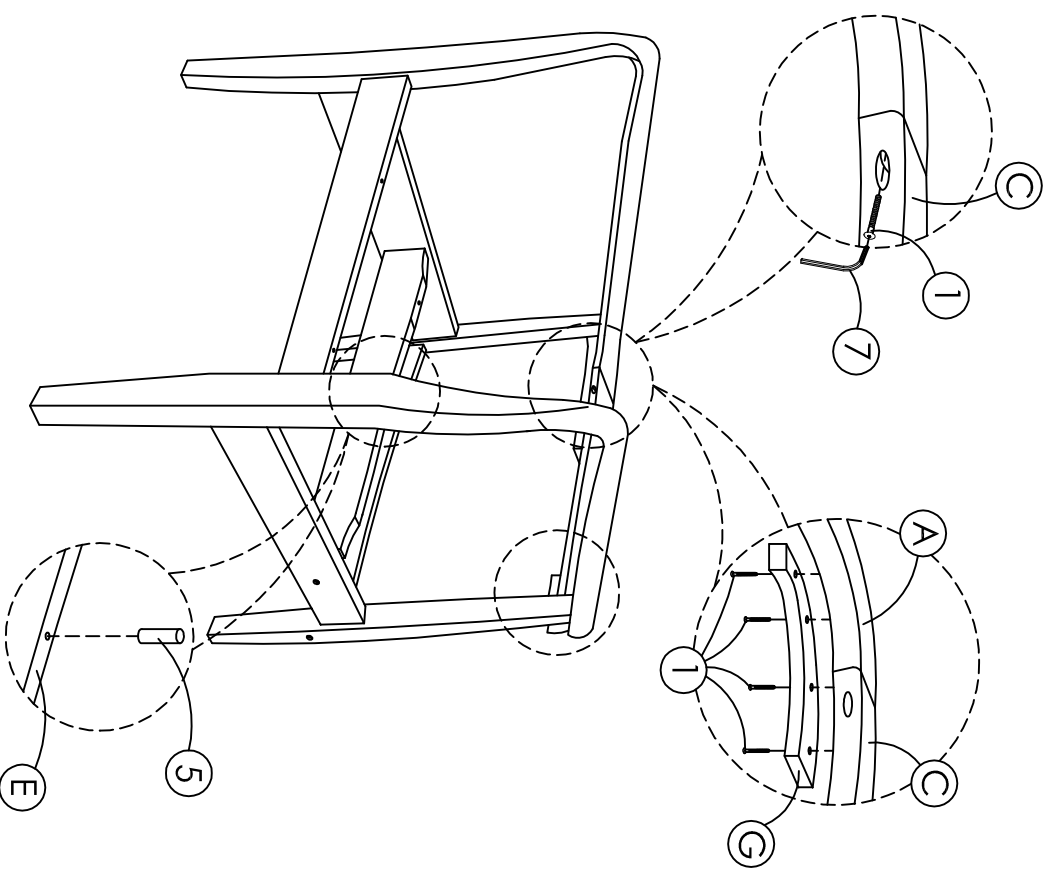

1. Tighten upper back rail (C) to arm chair left & right (A & B) with JCBC BOLT (1).
2. After that fix back rail support left & right (G & H) with JCBC BOLT (1) by using ALLEN KEY (7).
3. Then tighten all other jcbc bolts.
4. Insert WOOD DOWEL (5) to the hole center of center rail (E).

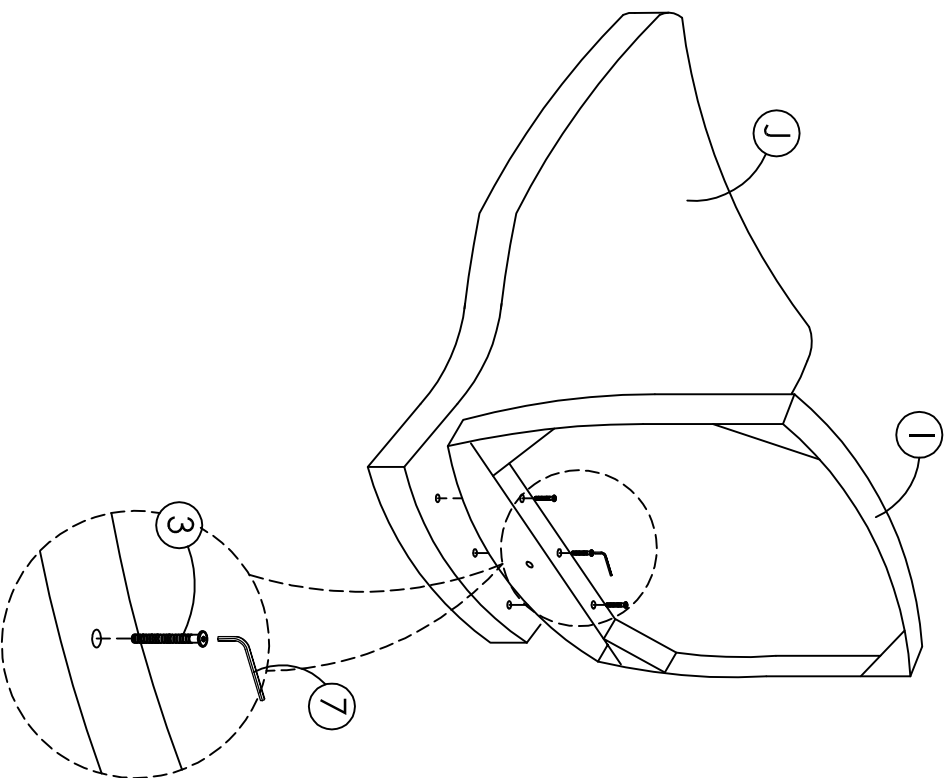

1. Place back rest (J) and seat deck (I) on a platform where the height is parallel with eye view.
2. Remove the black cover underneath of seat deck (I).
3. Fix seat deck (I) to back rest (J) with JCBC BOLT (3) by using ALLEN KEY (7).
4. Fix the black cover at its original position.

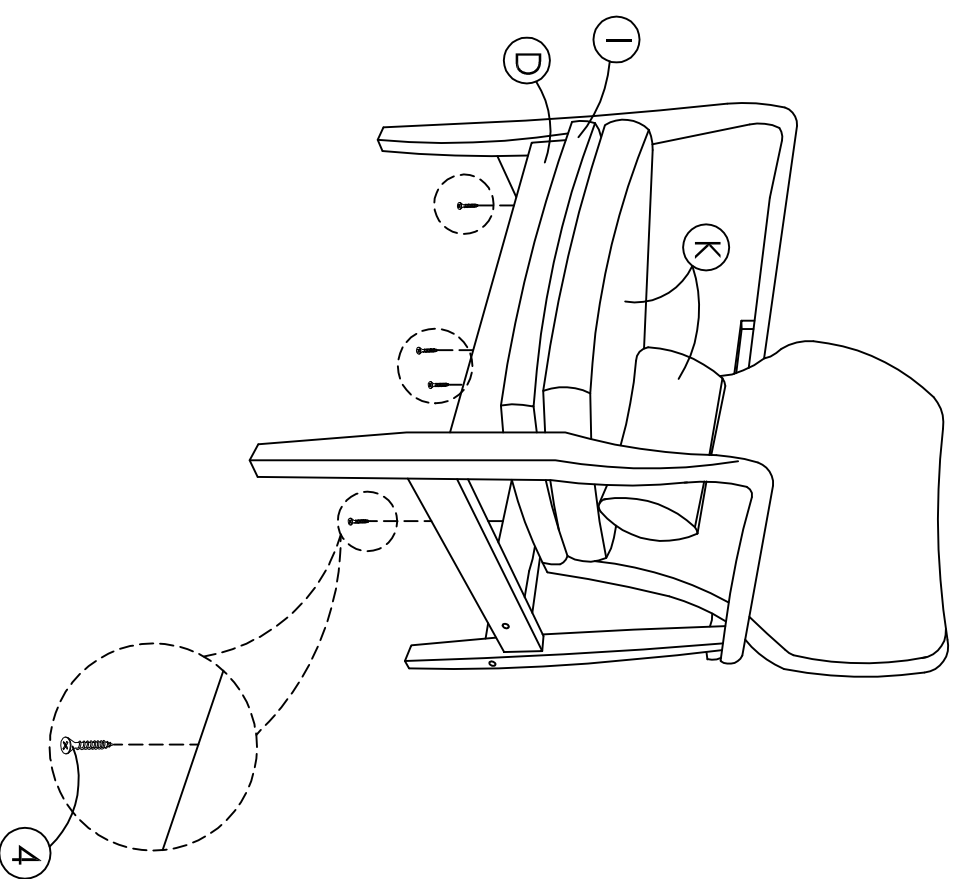

1. Place the seat deck (I) above front rail (D) and center rail (E).
2. Locate the position of wood dowel on center rail (E) and make sure the wood dowel fit into the hole underneath of seat deck (I).
3. Then screw from the bottom of front rail (D) and center rail (E) to seat deck (I) with WOOD SCREW (4).
4. Place the large & small cushion (K) above seat deck (I) as per picture shown.

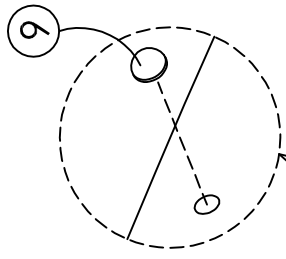
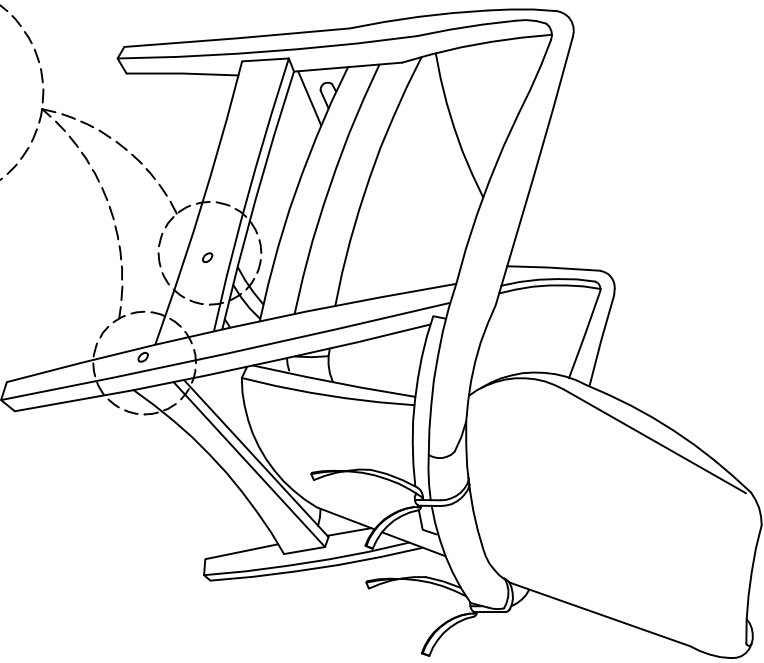

1. Cover the JCBC BOLTS with WOODEN CAP (6).
2. Tie the ropes at the back properly.

