

# ASSEMBLY INSTRUCTIONS

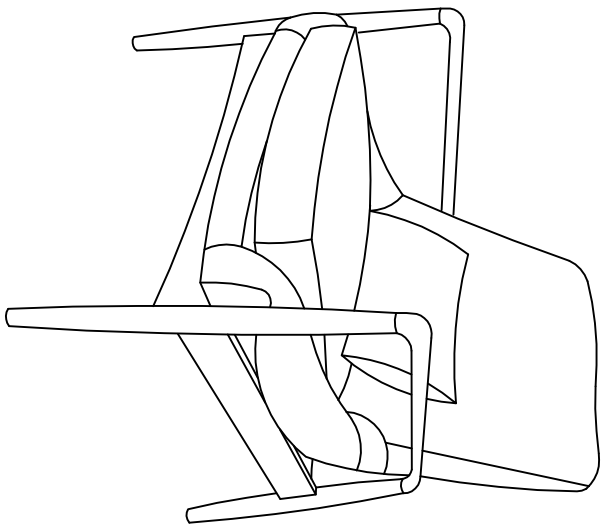

2 PEOPLE REQUIRED

## ASSEMBLY TIPS



1. Remove hardware from box and sort by size.
2. Please check to see that all hardware and parts are present prior start of assembly.
3. Please follow attached instructions in the same sequence as as numbered to assure fast and easy assembly.
4. Estimated 45 minutes required for assembly.





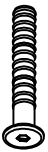
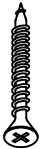
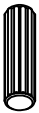

Warning !

1. Don't attempt to repair or modify parts that are broken or defective. Please contact the store immediately.
2. This product is for home use only and not intended for commercial establishments.

## HARDWARE LIST

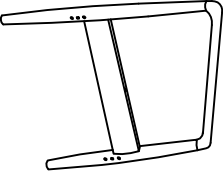
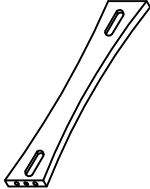
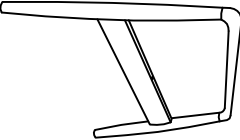
1		4 PCS	
2	JCBC M6 x 40mm 	4 PCS	
3	WOOD SCREW 4.0 x 50mm 	9 PCS	
4	WOOD DOWEL Ø10 x 30mm 	1 PC	

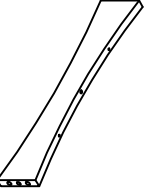
## COMPONENT LIST

A		1 SET	D		1 PC
B	ARM CHAIR (LEFT) 	1 SET	E	SEAT DECK 	1 PC
C	ARM CHAIR (RIGHT) 	1 PC	F	CUSHION (LARGE)	
			G	CUSHION (SMALL) 	1 PC

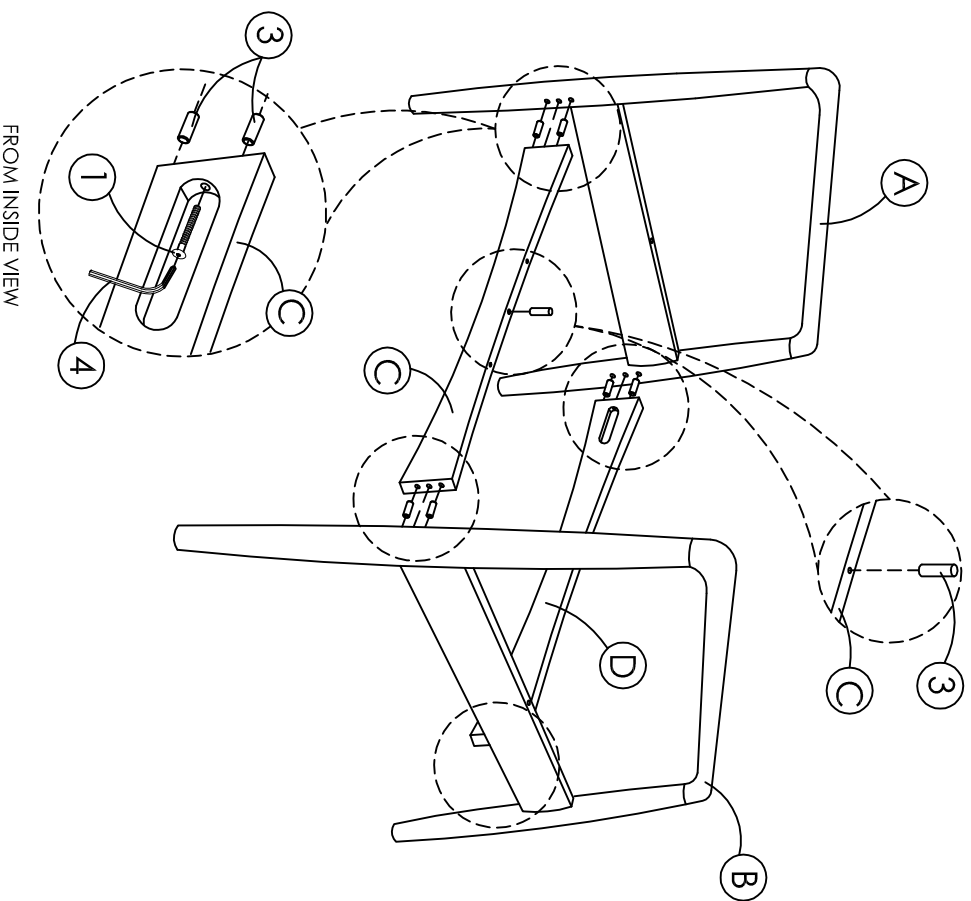

1. Fix arm chair left & right (A & B) to front rail (C) by using WOOD DOWEL (3) and JCBC BOLT (1). Do not fully tighten.
2. Then fix back rail (D) to arm chair left & right (A & B) by using WOOD DOWEL (3) and JCBC BOLT (1).
3. Insert WOOD DOWEL (3) to the center hole of front rail (C).

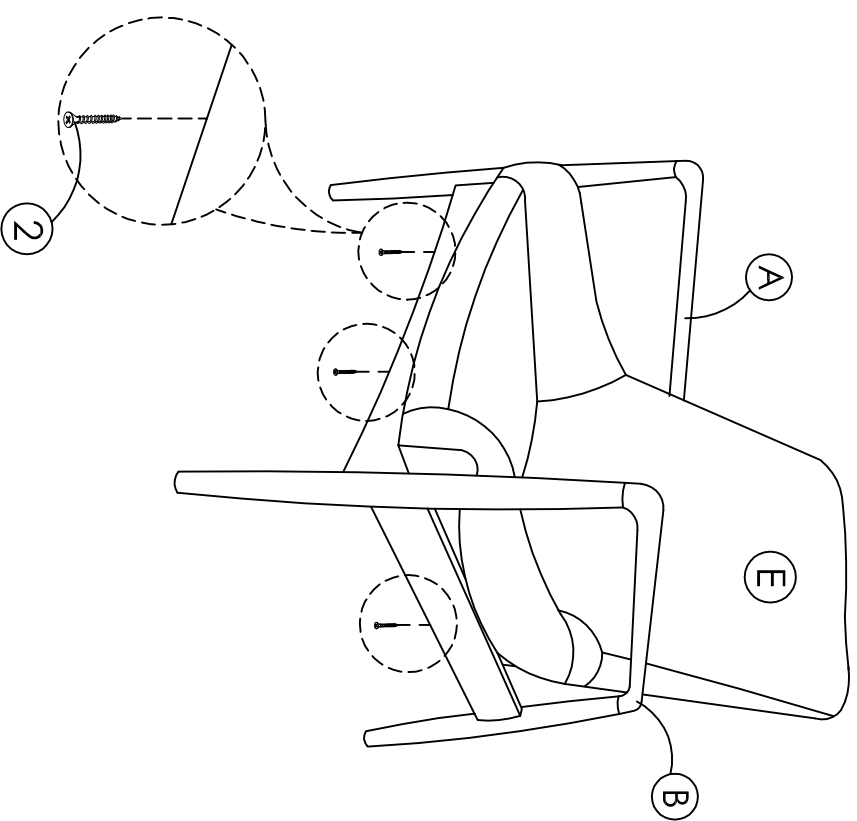

1. Place the seat deck (E) above front rail (C) and back rail (D).
2. Locate the position of wood dowel on front rail (C) and make sure the wood dowel fit into the hole underneath of seat deck (E).
3. Then, tighten all JCBC BOLT.
4. After that, screw from the bottom of front rail (C) and arm chair left & right (A & B) to seat deck (E) with WOOD SCREW (2).

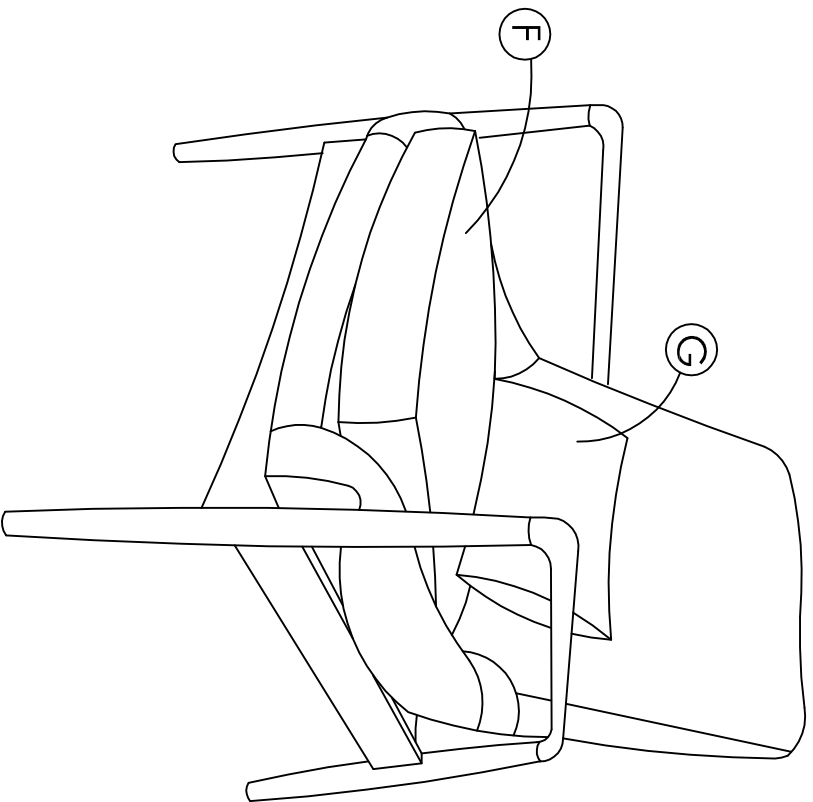

1. Place the large & small cushion (F & G) above seat deck (E) as per picture shown.

